

INCLINATION REFERS TO COMPLETE TOP RIM

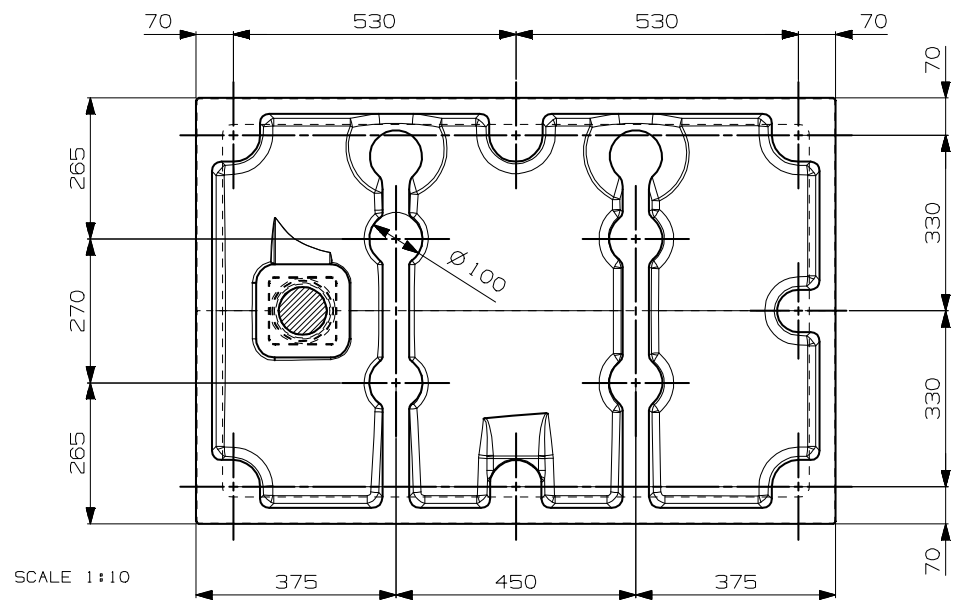
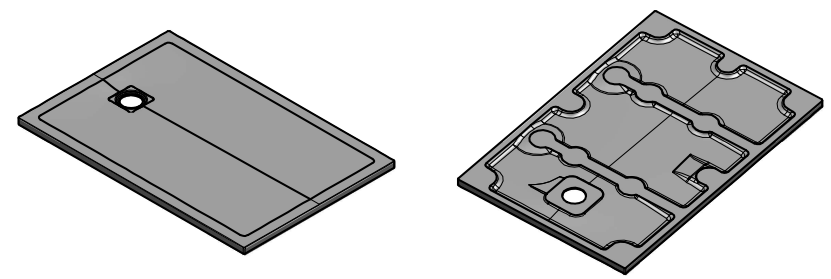
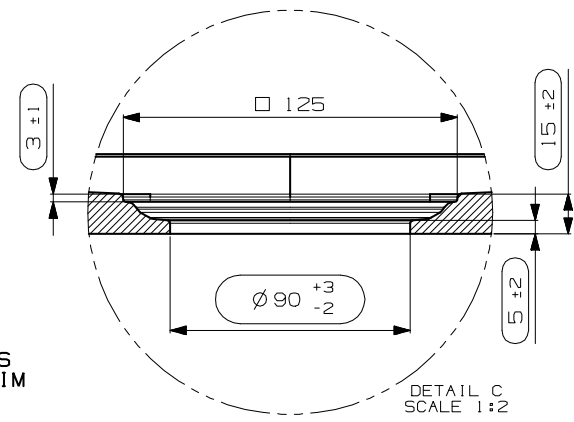

MATERIALE: MINERALSOLID  
FINITURA: ARDESIA

N° DATA/Date	FIRMA/drawn by	DESCRIZIONE REVISIONE/Revision description
1		

NOTE/Notes	N° STAMPO/Mould Number
.....	<b>MOB103A</b>
.....	PROG. 19-004
.....	PESO NETTO/Weight
VEDI SCHEDE ALLEGATE	<b>Kg. 36,5</b>
.....	PS 2000
.....	DATA REV.0/Date Rev.0
.....	<b>23/07/2019</b>
CLIENTE/Client	MODELLO/Model
<b>NICOS INT.</b>	<b>ARDESIA</b>
DENOMINAZIONE/Product Name	VERIFICATO/Checked by
<b>PIATTO DOCCIA 120x80</b>	<b>A. MANIAGO</b>
TUTTE LE QUOTE E TOLLERANZE INDICATE IN QUESTO DISEGNO SI RIFERISCONO A MISURAZIONI EFFETTUATE AD UNA TEMPERATURA DEL MANUFATTO DI 20°C +/-5°C.	PROIEZIONE/Projection
All the dimensions and the tolerances of this drawing are referred to measurements taken with a temperature of the piece of 20°C +/-5°C.	