

SECTION E-E
SCALE 35:200

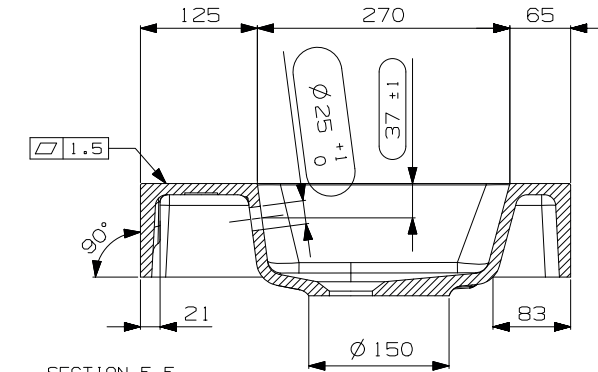

SECTION F-F
SCALE 35:200

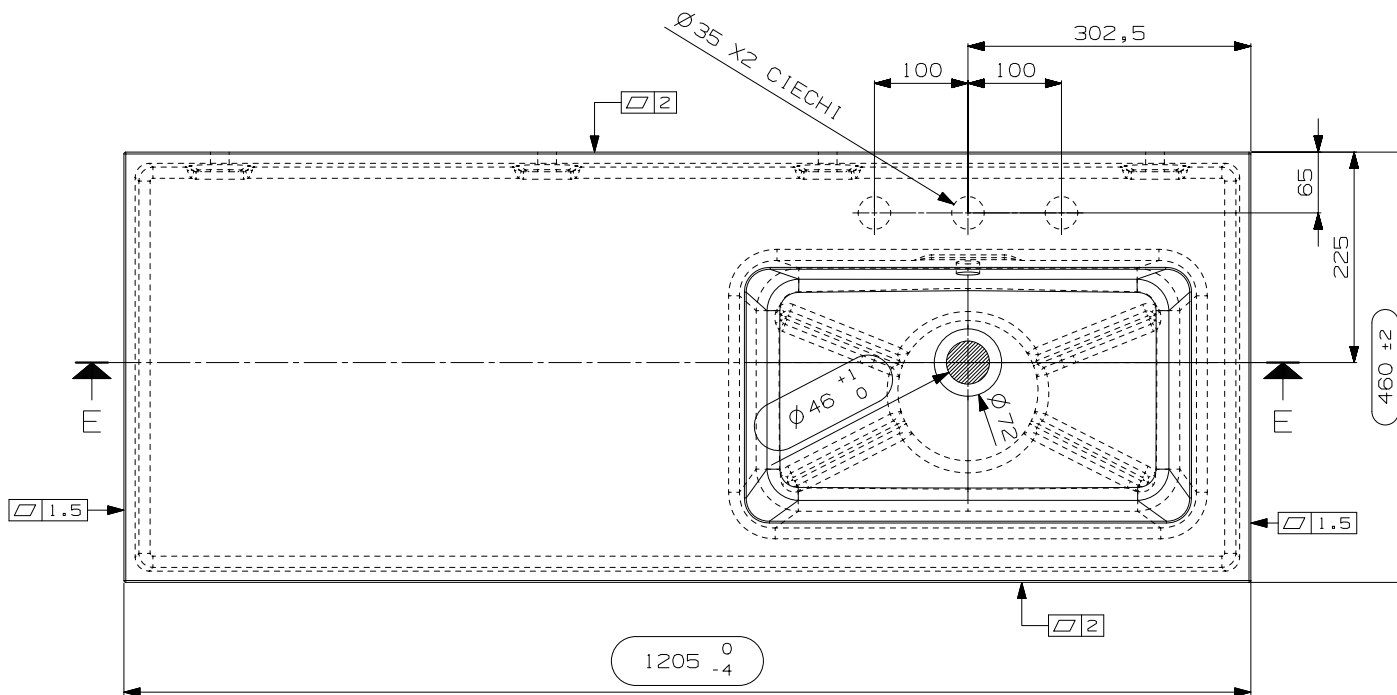

PER FINITURA LUCIDA
(4070396) N° 1 LIBR.USO MANUTENZ.CERAMILUX GLOSSY

PER FINITURA OPACA
(4070397) N° 1 LIBR.USO MANUTENZ.CERAMILUX MATT
(BULSAN) N° 1 SCOTCH BRITE GREY 100x150

(EACC508) N° 1 SCARICO A 1 VIA CON TROPPO PIENO

N° DATA/Date	FIRMA/drawn by	DESCRIZIONE REVISIONE/Revision description
04/07/24	FABRIZIO D.	VARIATA TOLLERANZA DA +/-2 A +/-4 (vedi mail Bulsan/Federica)
07/07/21	FABRIZIO D.	VARIATA DESCRIZIONE E AGGIUNTI ACCESSORI

NOTE/Notes	N° STAMPO/Mould Number	
VEDI SCHEDE ALLEGATE	M08239A	
	Prog.18-146	
	PESO NETTO/Weight	
	Kg.25	
	DATA REV.0/Date Rev.0	
	18/06/2020	
CLIENTE/Client	MODELLO/Model	EMESSO/Drawn by
NICOS INT.	SHARK	S.SANTAROSSA
DENOMINAZIONE/Product Name		VERIFICATO/Checked by
BASIN 120x46 RIGHT NO/H - W/OF		A.MANIAGO