

SECTION H-H
SCALE 35:200

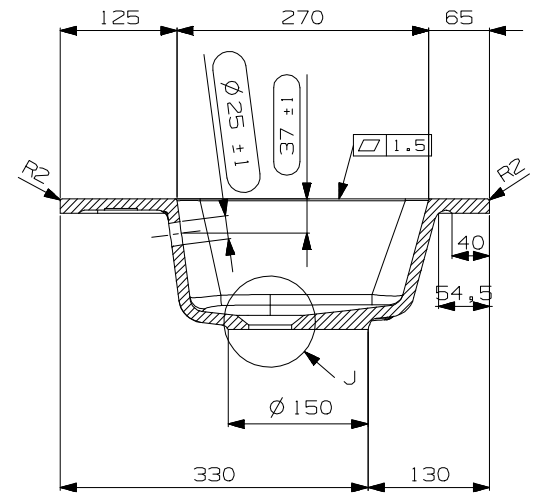

SECTION G-G
SCALE 35:200

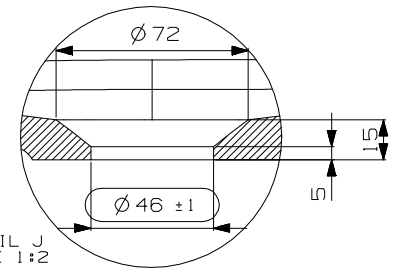
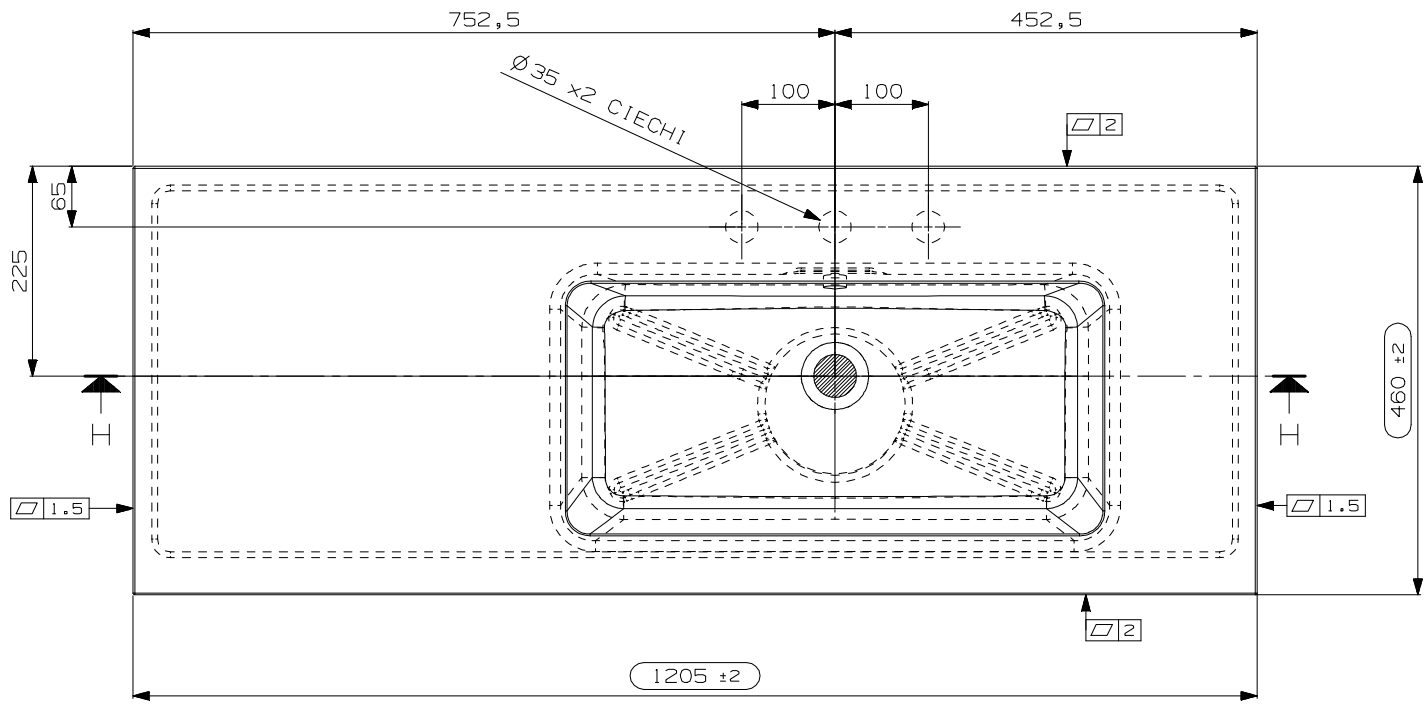

DETAIL J
SCALE 1:2

N° DATA/Date	FIRMA/drawn by	DESCRIZIONE REVISIONE/Revision description
1		

NOTE/Notes		N° STAMPO/Mould Number
.....		MO8383A
VEDI SCHEDE ALLEGATE		Prog.22-056
.....		PESO NETTO/Weight
.....		Kg. 17,4
.....		D.2000 kg/m3
.....		DATA REV.0/Date Rev.0
.....		29/08/2022
CLIENTE/Client	MODELLO/Model	EMESSO/Drawn by
NICOS INT.	MAX	S. SANTAROSSA
DENOMINAZIONE/Product Name		VERIFICATO/Checked by
BASIN 120x46 RIGHT N/H - W/OF		A. MANIAGO