

SECTION H-H
SCALE 35:200

CALIBRARE

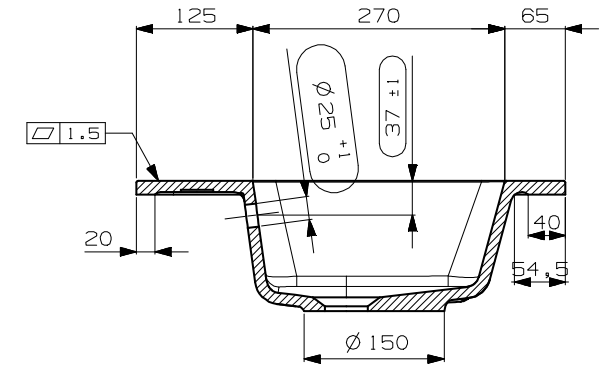

SECTION I-I
SCALE 35:200

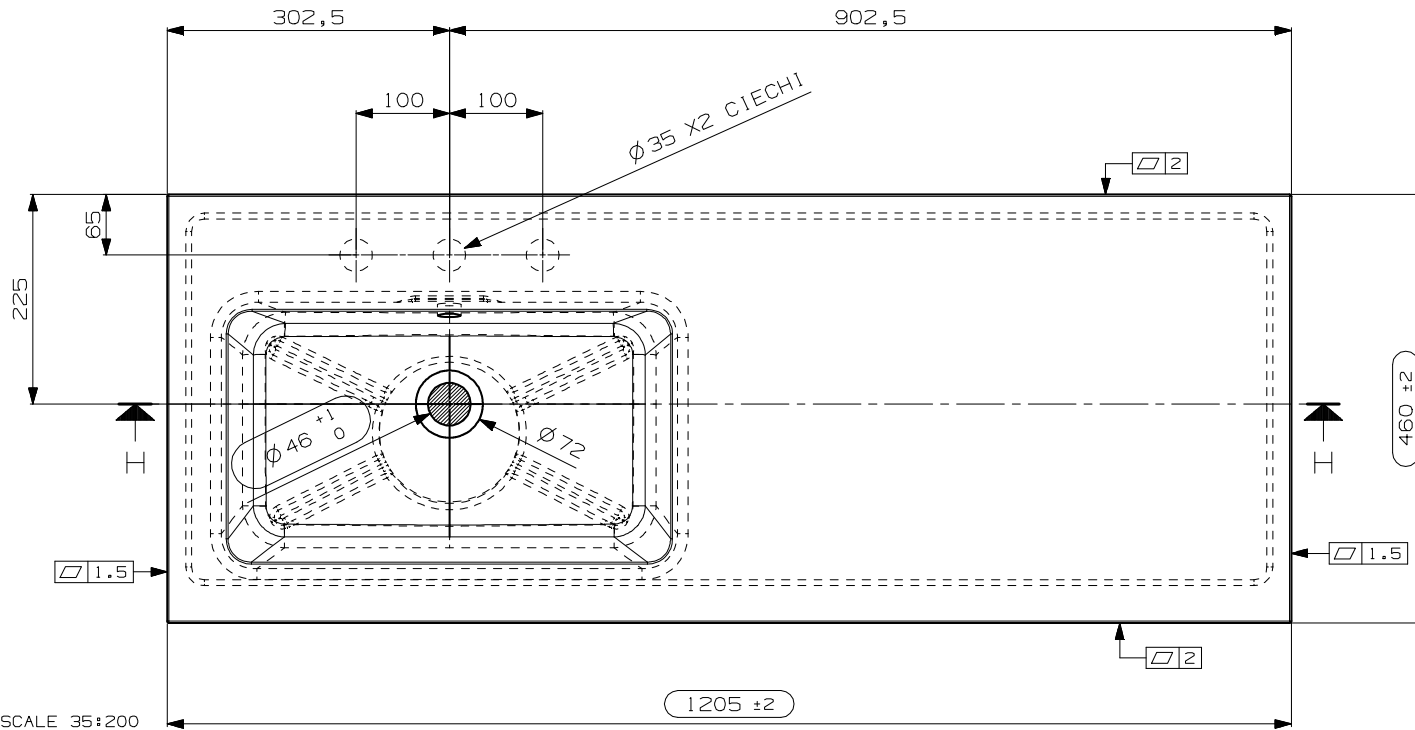

SCALE 35:200

N° DATA/Date	FIRMA/drawn by	DESCRIZIONE REVISIONE/Revision description
1		

NOTE/Notes		N° STAMPO/Mould Number
.....		MOB210A
VEDI SCHEDE ALLEGATE		Prog. 18-146
.....		PESO NETTO/Weight
.....		Kg. 17,5
.....		DATA REV.0/Date Rev.0
.....		18/06/2020
CLIENTE/Client	MODELLO/Model	EMESSO/Drawn by
NICOS INT.	MAX	S. SANTAROSSA
DENOMINAZIONE/Product Name		VERIFICATO/Checked by
LAVABO SX 120x46 VASCA 48 S/F - C/TP		A. MANIAGO
TUTTE LE QUOTE E TOLLERANZE INDICATE IN QUESTO DISEGNO SI RIFERISCONO A MISURAZIONI EFFETTUATE AD UNA TEMPERATURA DEL MANUFATTO DI 20°C +/-5°C.		PROIEZIONE/Projection
All the dimensions and the tolerances of this drawing are referred to measurements taken with a temperature of the piece of 20°C +/-5°C.		