

SCALE 1:5

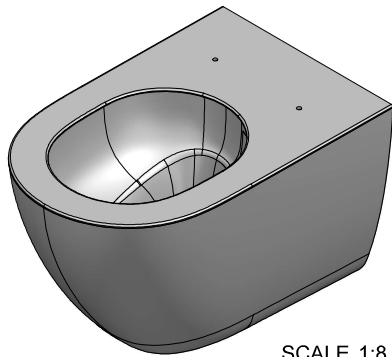

SCALE 1:8

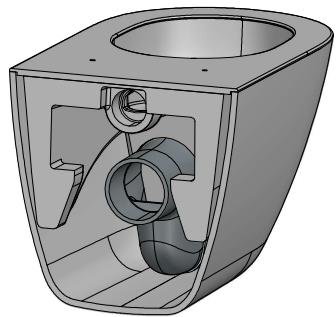

SCALE 1:8

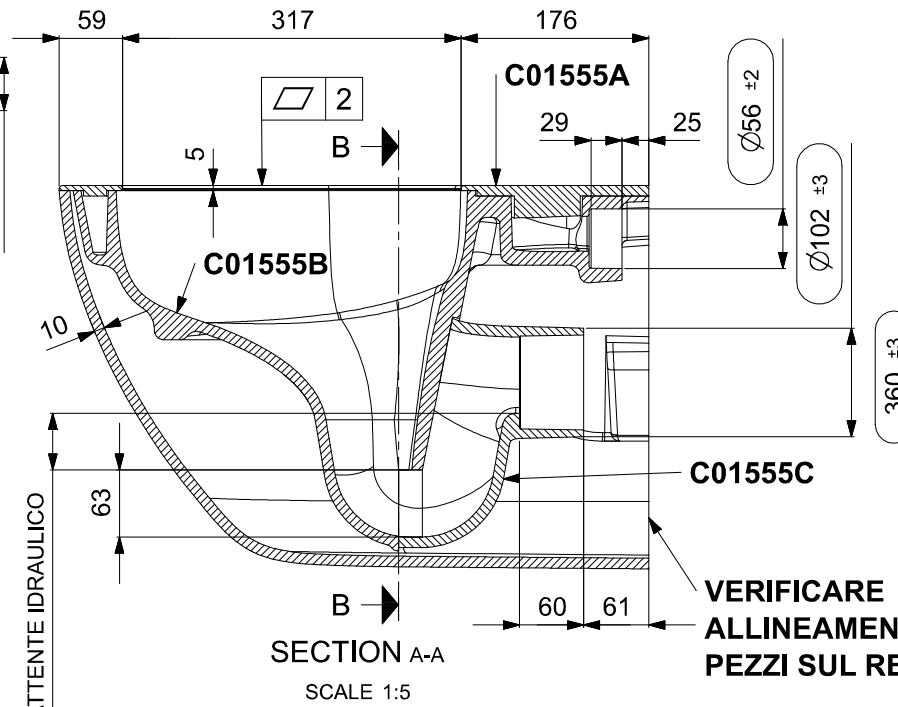

53 BATTENTE IDRAULICO

**VERIFICARE
ALLINEAMENTO
PEZZI SUL RETRO**

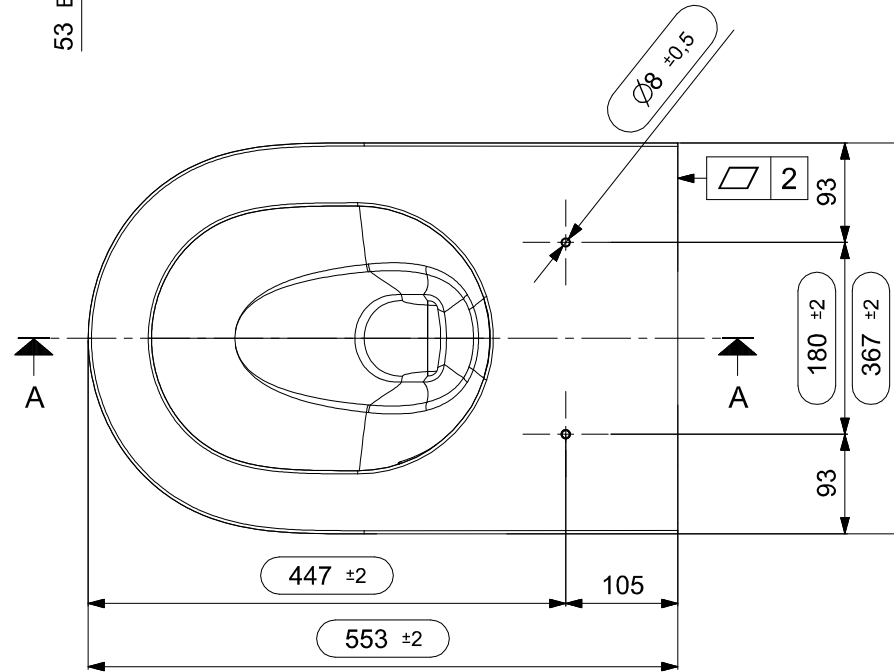
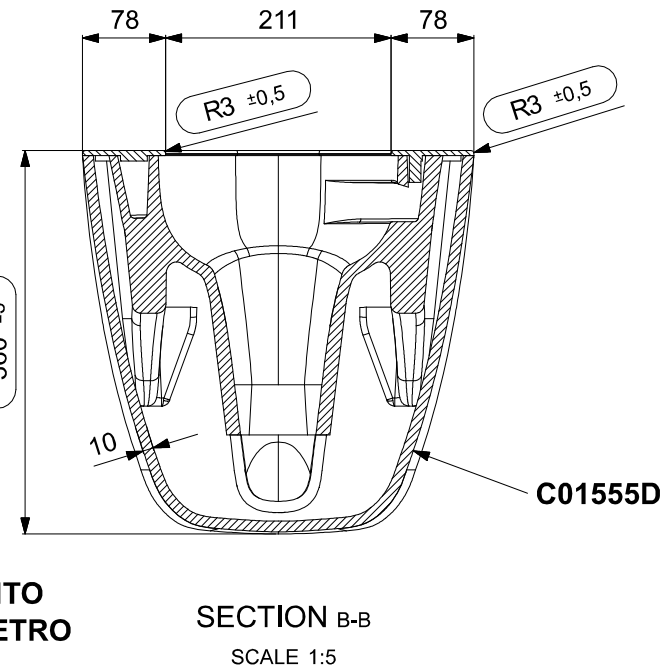

N° DATA/Date	FIRMA/drawn by	DESCRIZIONE REVISIONE/Revision description
1 16/09/25	MANIAGO A.	SCHEDA TECNICA
2 21/10/25	E.FRESCH	MODIFICA FORI FISSAGGIO COVER

NOTE/Notes	N° STAMPO/Mould Number
.....	C01555XE34
.....	PROG. 24 - 064
.....	PESO NETTO/Weight
.....	26 kg.
.....	DATA REV.0/Date Rev.0
.....	29/05/2025
CLIENTE/Client	MODELLO/Model
NICOS	KAPSEL
DENOMINAZIONE/Product Name	EMESSO/Drawn by
WC	E. FRESCH
	VERIFICATO/Checked by
	A. MANIAGO