

SECTION C-C
SCALE 1:5

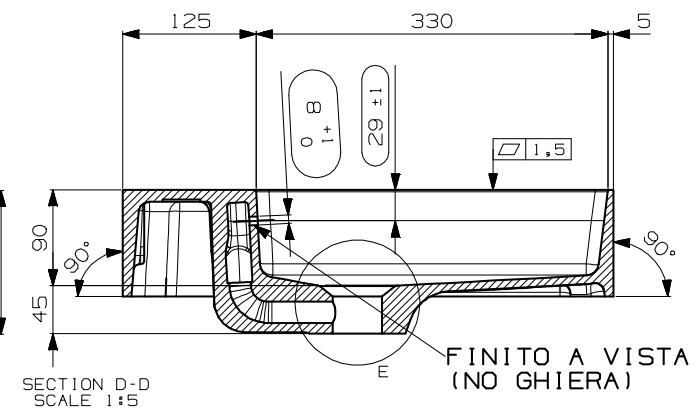

SECTION D-D
SCALE 1:5

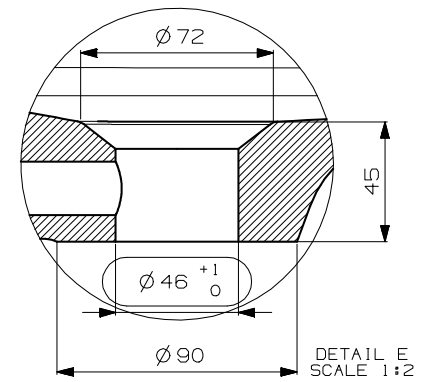

DETAIL E
SCALE 1:2

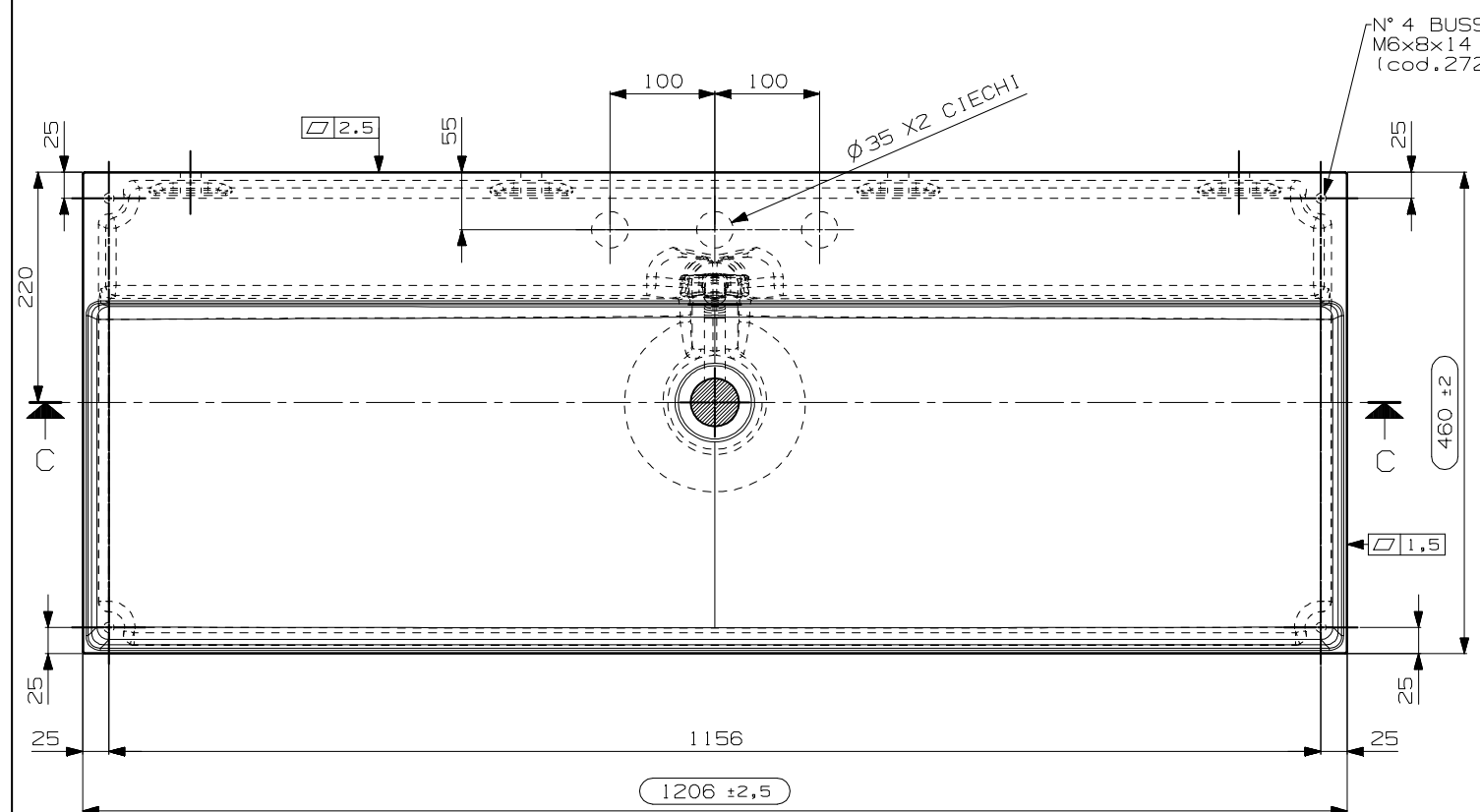

SCALE 1:5

PER FINITURA LUCIDA
(4070396) N° 1 LIBR.USO MANUTENZ.CERAMILUX LUCIDO

PER FINITURA OPACA
(KITPUL12) N° 1 KIT PULIZIA SSL OPACO

(2720595) N° 1 PIPETTA LAVANDINO
(4501054) 0,35 MT. TUBO RILSAN TRASP. Ø 18X20

| N° DATA/Date | FIRMA/drawn by | DESCRIZIONE REVISIONE/Revision description |
|--------------|----------------|--|
| 1 | | |

| | | |
|----------------------------|---------------|------------------------|
| NOTE/Notes | | N° STAMPO/Mould Number |
| | | MOB041A |
| | | PROG. 17-027 |
| | | PESO NETTO/Weight |
| | | Kg. 18,5 |
| | | DATA REV.0/Date Rev.0 |
| | | 24/06/2019 |
| CLIENTE/Client | MODELLO/Model | EMESSO/Drawn by |
| NICOS INT. | FIVE | S.SANTAROSSA |
| DENOMINAZIONE/Product Name | | VERIFICATO/Checked by |
| LAVABO 120x46 S/F | | A.MANIAGO |

TUTTE LE QUOTE E TOLLERANZE INDICATE IN QUESTO DISEGNO SI RIFERISCONO A MISURAZIONI EFFETTUATE AD UNA TEMPERATURA DEL MANUFATTO DI 20° C +/- 5° C.

All the dimensions and the tolerances of this drawing are referred to measurements taken with a temperature of the piece of 20° C +/- 5° C.