

SECTION D-D
SCALE 1:5

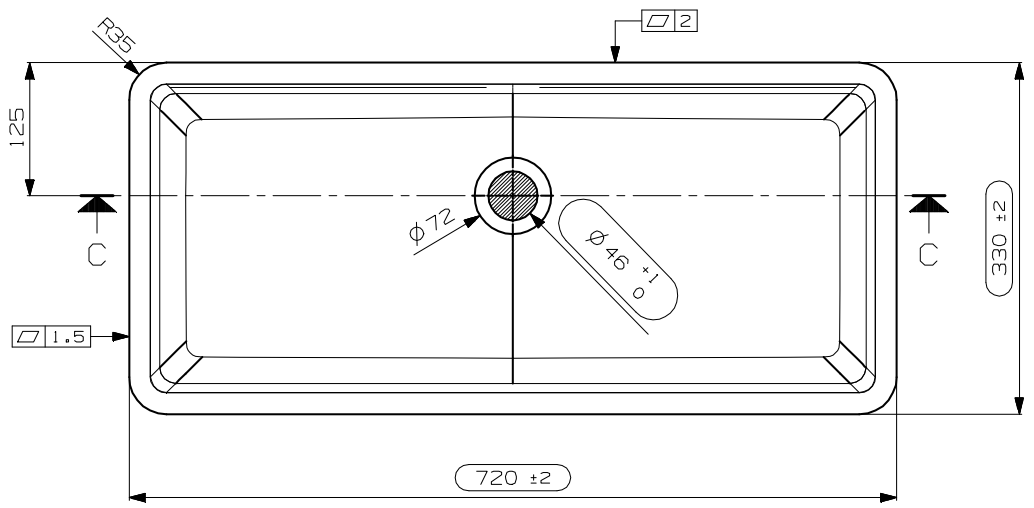

SCALE 1:5

PER FINITURA LUCIDA
(4070396) N° 1 LIBR.USO MANUTENZ.CERAMILUX LUCIDO

PER FINITURA OPACA
(KITPUL12) N° 1 KIT PULIZIA SSL OPACO

N° DATA/Date	FIRMA/drawn by	DESCRIZIONE REVISIONE/Revision description
1		

NOTE/Notes	N° STAMPO/Mould Number
.....	MO8185A
.....	PROG. 13-306
.....	PESO NETTO/Weight
.....	Kg. 6,5
.....	DATA REV.0/Date Rev.0
.....	29/08/2019
CLIENTE/Client	MODELLO/Model
NICOS INT.	(7383)
DENOMINAZIONE/Product Name	EMESSO/Drawn by
VASCHETTA SOTTOPIANO	S.SANTAROSSA
	VERIFICATO/Checked by
	A.MANIAGO