

SECTION A-A  
SCALE 1:5

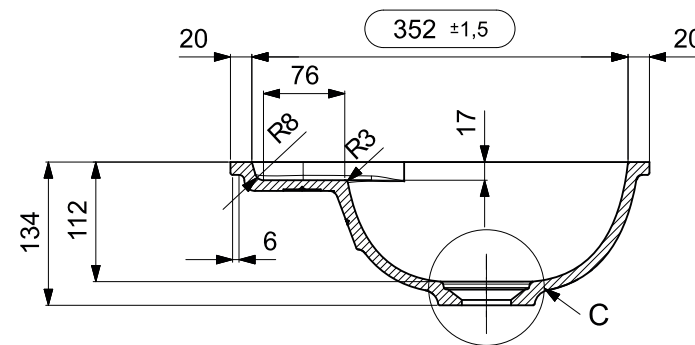

SECTION B-B  
SCALE 1:5

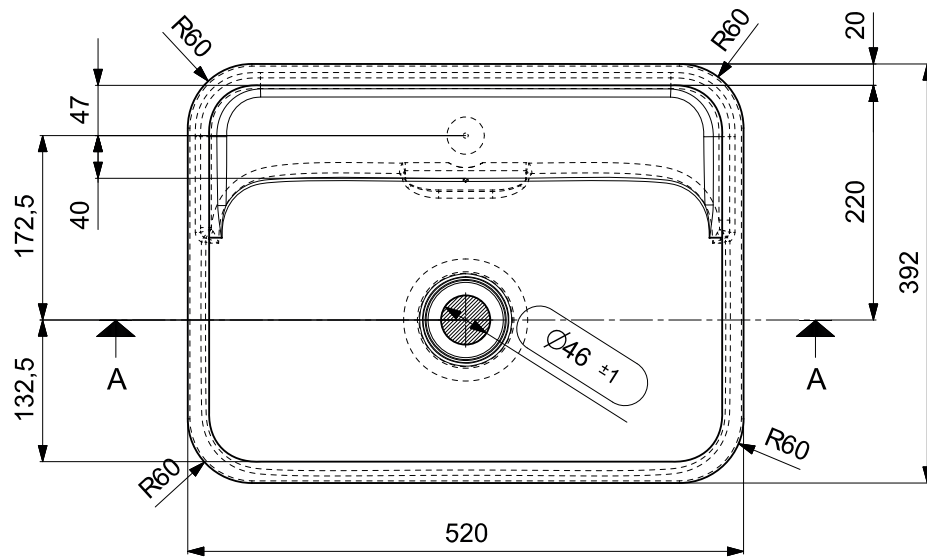

SCALE 1:5

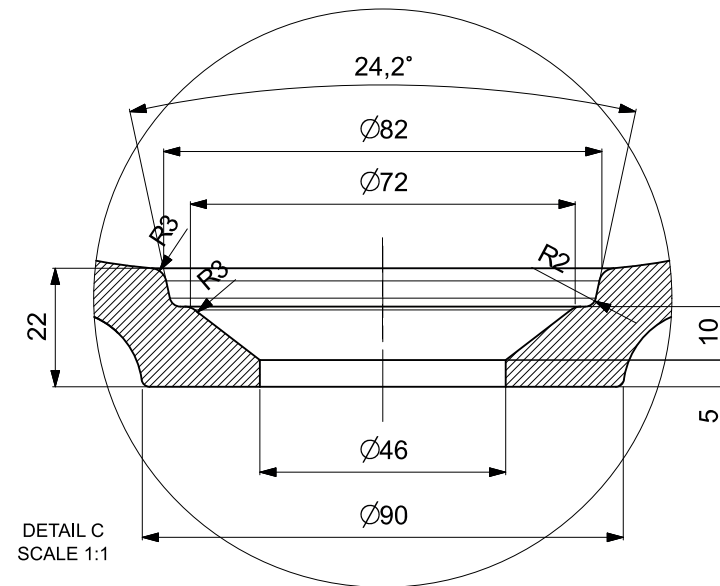

DETAIL C  
SCALE 1:1

N° DATA/Date	FIRMA/drawn by	DESCRIZIONE REVISIONE/Revision description
1		

NOTE/Notes		N° STAMPO/Mould Number
.....		C01554A
.....		PROG.25-012
.....		PESO NETTO/Weight
.....		5 kg
.....		DATA REV.0/Date Rev.0
.....		20/10/2025
CLIENTE/Client	MODELLO/Model	EMESSO/Drawn by
NICOS	BLADE B	E.FRESCH
DENOMINAZIONE/Product Name		VERIFICATO/Checked by
VASCHETTA SOTTOPIANO		A.MANIAGO
TUTTE LE QUOTE E TOLLERANZE INDICATE IN QUESTO DISEGNO SI RIFERISCONO A MISURAZIONI EFFETTUATE AD UNA TEMPERATURA DEL MANUFATTO DI 20°C +/-5°C.		PROIEZIONE/Projection
All the dimensions and the tolerances of this drawing are referred to measurements taken with a temperature of the piece of 20°C +/-5°C.		.....