

20
22
01

Listino prezzi
Price list
Liste de prix



PROFESSIONAL

albi

- Azienda**
5 *Company*
Entreprise
- 7 **“Home made”**
- Rispetto dell’ambiente**
9 *Environment respect*
Respect de l’environnement
- Tecnologia termostatica**
10 *Thermostatic technology*
Technologie thermostatique
- Tecnologia monocomando**
11 *Single-lever technology*
Technologie monocommande
- Spazio al comfort**
12 *Comfort for everyone*
De l’espace au confort
- Idroterapia**
13 *Hydrotherapy*
Hydrothérapie
- Comfort della doccia**
14 *Shower comfort*
Confort de la douche
- Guida alla lettura della simbologia**
16 *Guide to reading the symbols*
Guide de lecture de la symbologie



18 Sport plus



32 City plus



48 Joy



60 Sport senior



68 Clinic MR

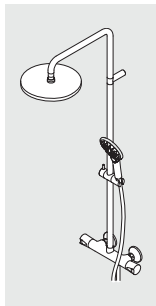

76 Colonne doccia

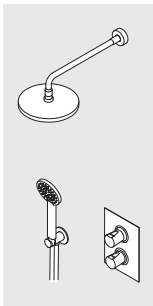

96 Shower set

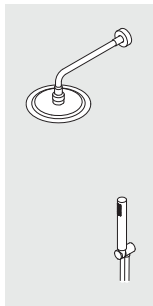

102 Idroterapia



128 Tender

134

Accessori e ricambi

Accessories and spare parts

Accessoires et pièces détachées

alpi

UFFICI OFFICE →
VISITATORI VISITORS ← P
↑





Azienda

*company
entreprise*

Alpi è un'azienda italiana fondata nel 1994 a Gattico Veruno, nei pressi di Milano. L'azienda ha due stabilimenti produttivi situati nella stessa area industriale, nel cuore del distretto storico di produzione dei rubinetti.

Alpi is an Italian firm established in 1994 in Gattico Veruno, not far from Milan. The company has two plants in the same industrial area, in the heart of the storied taps and fittings production district.

Alpi est une entreprise italienne fondée en 1994 à Gattico Veruno, près de Milan. L'entreprise possède deux usines de production situées dans la même zone industrielle, au cœur du quartier historique de la production de robinets.





“Home made”

Alpi rappresenta una realtà produttiva dalla forte connotazione tecnologica e attitudine a gestire al suo interno la gran parte della filiera di produzione della rubinetteria, con la massima qualità.

Alle lavorazioni meccaniche di avanguardia si unisce un Reparto di Sviluppo Tecnico di eccellenza. Le capacità tecnologiche si associano al saper fare dei tecnici che si occupano della produzione. Una squadra appassionata che ogni giorno dà forma fisica alla qualità dei prodotti.

Alpi is a production reality with a strong technological flair that manages most of its production flow in house to offer the best quality. Our cutting-edge mechanical processes are combined to a first-class Research & Development department. Our technological skills go hand in hand with the know-how of our production engineers. A passionate team bringing to life product quality.



Alpi représente une réalité de production à forte connotation technologique et une aptitude à gérer en interne la majeure partie de la chaîne de fabrication des robinets de très haute qualité. Un excellent département de développement technique s'associe aux usinages mécaniques de pointe proposés. Les compétences technologiques sont associées au savoir-faire des techniciens impliqués dans la production. Jour après jour, une équipe passionnée garantit donne forme à des produits d'une qualité optimale.



alpi

alpi

alpi

alpi

Rispetto dell'ambiente

environment respect
respect de l'environnement

Company certification
UNI EN ISO 9001



Product certification
ACS



Alpi promuove un utilizzo consapevole delle risorse ambientali tramite i propri prodotti e tecnologie perseguendo obiettivi quali il **risparmio energetico** e il **risparmio idrico**.

RISPARMIO ENERGETICO

I miscelatori termostatici Alpi raggiungono la temperatura desiderata il più rapidamente possibile mantenendola costante, riducendo il tempo di combustione e la conseguente immissione di anidride carbonica nell'aria.

RISPARMIO IDRICO

L'abbinamento tra la funzione **AIRmix** che miscela aria/acqua e la funzione **ECOstop** come limitatore di erogazione economizza fino a 8 L/min facendo però percepire la sensazione di 14 L/min l'equivalente della portata di un miscelatore tradizionale.

*Alpi promotes a conscious use of the environmental resources through its products and technologies pursuing **water and energy saving**.*

ENERGY SAVING

The first feature of the Alpi thermostatic mixer is to get to the desired temperature in the shortest time and to keep it constant, reducing the time of hot water heating and the consequent emission of carbon dioxide in the air.

WATER SAVING

*The **ECOstop** function that limits the flow of water saving up to 50% combined with the **AIRmix** technology that mixes the water with air, allows to save up to 8 lit/min, while giving the feeling of 14 lit/min, that is the flow rate of a conventional mixer.*

Alpi encourage une utilisation consciente des ressources environnementales à travers ses produits et ses technologies, en poursuivant des objectifs tels que **les économies d'énergie et d'eau**.

ÉCONOMIES D'ÉNERGIE

Les mitigeurs thermostatiques Alpi atteignent la température souhaitée le plus rapidement possible et la maintiennent constante, ce qui réduit le temps de combustion et le dégagement de dioxyde de carbone dans l'air qui en résulte.

ÉCONOMIES D'EAU

La combinaison de la fonction **AIRmix**, qui mélange l'air et l'eau, et de la fonction **ECOstop** comme limiteur de débit permet d'économiser jusqu'à 8 L/min, tout en donnant à l'utilisateur la sensation de disposer de 14 litres d'eau par minute, le débit équivalent d'un mitigeur traditionnel.

Tecnologia termostatica

thermostatic technology
technologie thermostatique

38°



SELFcontrol

Morbidezza e precisione
nell'impostazione della temperatura

*Soft and precise adjustment
of the temperature*

*Souplesse et précision dans
le réglage de la température*

Marchatura indelebile per
identificazione e tracciabilità
*Permanent marking for
recognition and production date*

Marquage permanent
pour identification et traçabilité

Doppio sistema di filtraggio acqua
più pura, portata garantita

*Double filtering system purer water,
flowrate guaranteed*

Double système de filtrage eau
plus pure débit garanti

SPEEDcontrol

Nuovo sensore più rapido
nell'impostazione della giusta
temperatura

*New sensor faster in the right
temperature setting*

*Nouveau capteur plus rapide dans
le réglage de la juste température*



Realizzata utilizzando esclusivamente
tecnopolimeri ad alte prestazioni

*It is made using only
high-performance technopolymers*

Est réalisé en utilisant exclusivement
des technopolymères hautement
performants

Nuova meccanica consente
più di 50.000 cicli di regolazione

*New mechanics allows more
than 50.000 adjustment cycles*

Nouvelle technologie qui garantit
plus de 50.000 cycles de réglages



PROtherm

Grazie alla tecnologia
PROtherm il miscelatore
termostatico non scotta
mai esternamente

*The thermostatic mixers
never burn externally
thanks to the PROtherm
technology*

Grâce à la technologie
PROtherm, le mitigeur
thermostatique ne brûle
jamais à l'extérieur

SECUREstop

Blocco della
temperatura a 38°

*Temperature
block at 38°*

Verrouillage de la
température à 38°

EASYsystem

Pratico sistema di
montaggio e smontaggio

*Easy system of assembly
and disassembly*

Pratique système de
montage/démontage

ECOstop

Limita l'erogazione
dell'acqua con un
risparmio fino al 50%

*Limits the flow of water
saving up to 50%*

Permet d'économiser
jusqu'à 50% d'eau

Acque invertite

Cartuccia termostatica
per acque invertite
facilmente sostituibile
senza interventi murari

*Thermostatic cartridge
for incorrect water
connections easily
replaceable without
interventions of masonry*

Cartouche
thermostatique pour
incorrecte raccordement
des eaux facilement
remplaçable sans
travaux de maçonnerie

Tecnologia monocomando

single-lever technology
technologie monocommande



Realizzata con tecnopolimeri di avanguardia che garantiscono affidabilità e durabilità nel tempo con più di 175.000 cicli di regolazione

It is made using only high-performance technopolymers that allow reliability and durability with more than 175.000 adjustment cycles

Est réalisé en utilisant exclusivement des technopolymères hautement performants qui garantit fiabilité et durabilité dans le temps avec plus de 175.000 cycles de réglages

Morbidezza nella regolazione del flusso e precisione nella regolazione della temperatura

Soft adjustment of the flow and precise adjustment of the temperature

Régularité du réglage du débit et précision du réglage de la température



Nuova meccanica silenziosa
New silent mechanics
Nouvelle technologie silencieuse

Marchatura indelebile per riconoscibilità e data di produzione
Permanent marking for recognition and production date

Marquage permanent pour identification et traçabilité



ECOstart



ECOstop



Antitorsione



Aeratori limitati

Con la funzione ECOstart aprendo il miscelatore in posizione frontale si ottiene la sola erogazione di acqua fredda con conseguente risparmio energetico

Single-lever mixers use ECOstart cartridges. Open the lever in front position to get only cold water with a total energy saving

Les mitigeurs monocommande sont équipés de la cartouche ECOstart. En utilisant la manette en position centrale on obtient uniquement de l'eau froide ce qui permet d'économiser de l'énergie

Limita l'erogazione dell'acqua con un risparmio fino al 50%

Limits the flow of water saving up to 50%

Permet d'économiser jusqu'à 50% d'eau

Il sistema antitorsione consente ai raccordi flessibili inox la libertà di rotazione garantendone l'integrità

The torsion prevention system allows the stainless steel flexible fittings to be free to rotate guaranteeing their integrity

Le système anti-torsion permet aux raccords flexibles inox la liberté de rotation en garantissant l'intégrité

Al fine di limitare il flusso d'acqua tutti i nostri miscelatori sono dotati di aeratori limitati secondo le normative vigenti

In order to limit the water flow, all our mixers are equipped with flow limited aerators in accordance to the standard regulation

Afin de limiter le débit d'eau, tous nos mitigeurs sont équipés d'aérateurs limités conformément aux réglementations en vigueur

Spazio al comfort

comfort for everyone
de l'espace au confort

L'ampio assortimento delle gamme Alpi e le varie tipologie di lavabo offrono libertà assoluta per arredare le sale da bagno sia dal punto di vista estetico che dalla facilità d'uso.

The wide selection of Alpi's ranges and the different types of basin taps enable you to feel free to decorate the bathroom both from an aesthetic and user-friendliness point of view.

Le large éventail des gammes Alpi et les différents types de lavabos offrent une liberté absolue pour l'aménagement des salles de bains, tant du point de vue de l'esthétique que de la facilité d'utilisation.

(R)

↑ Installazione da appoggio
Surface mounting
↓ Installation à poser



(M)

↑ Installazione da appoggio
Surface mounting
↓ Installation à poser



(T)

↑ Installazione da appoggio
Surface mounting
↓ Installation à poser



(W)

↑ Installazione a parete
Wall mounting
↓ Installation mural



Idroterapia

soffioni doccia
shower heads
pommes de douche

20° ampio raggio di regolazione
20° wide possibility of adjustment
Large plage de réglage de 20°

Limitatore di portata 9L/min
Flow limiter 9L/min
Limiteur de débit 9L/min



Snodo in ottone cromato
Connection in chromed brass
Joint à rotule en laiton chromé



Ugelli anticalcare inalterabili nel tempo
Durable anti-scale water nozzles
Buses anticalcaire inaltérables dans le temps

kit doccia
shower kit
kit douchette

Inserto antigraffio
Antiscratch insert
Protection contre les rayures



Il sistema di fissaggio garantisce il corretto
posizionamento della doccetta sul supporto
*The fixing system guarantees the correct
handset position on the bracket*
Le système de fixation garantit le bon
positionnement de la douchette sur le support

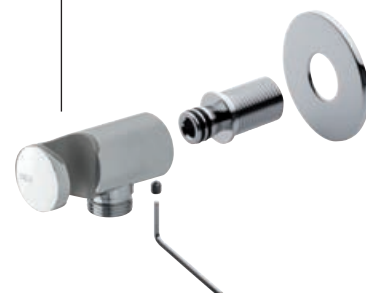

Comfort della doccia

shower comfort
confort de la douche

Termostatico
thermostatic
thermostatique



Monocomando
single-lever
monocommande



PROtherm

Grazie alla tecnologia PROtherm il miscelatore termostatico e monocomando non scotta mai esternamente

The thermostatic and single-lever mixers never burn externally thanks to the protherm technology

Grâce à la technologie PROtherm, le mitigeur ne brûle jamais à l'extérieur



ANTIcal

Tutte le nostre colonne doccia sono dotate di soffione e doccette anticalcare

All our shower columns are equipped with anti-scale shower heads and handsets

Toutes nos colonnes de douche sont munies de la pomme de douche et de douchettes anticalcaire



Braccio orientabile

Colonne doccia dotate di braccio orientabile

Shower columns with swivelling shower arms

Colonnes de douche avec bras de douche pivotant



Cursori regolabili

Tutti i cursori saliscendi sono regolabili in altezza

All vertical sliding cursors are adjustable in height

Tous les curseurs coulissants sont réglables en hauteur



FIXlong

Eccentrici più lunghi e rinforzati

S-union "FIX LONG" longer and reinforced

Raccords excentriques plus longs et renforcés



Colonne adattabili

E' possibile adattare l'altezza delle colonne tagliando il tubo

Possibility to adjust the height of the columns by cutting the tube

Possibilité d'adapter la hauteur des colonnes en coupant le tube

Termostatico

thermostatic
thermostatique



SECUREstop

Blocco della temperatura a 38°

Temperature block at 38°

Bouton pour le verrouillage
de la température à 38°



DVPRO

La nuova cartuccia deviatrice
in ottone ECObrass con dischi
ceramici auto-lubrificanti
in ossido di alluminio assicura
movimenti leggeri e precisi nel tempo

*The new brass diverter cartridge
ECObrass with aluminium oxide
self-lubricating ceramic disks
allow light and precise movement*

La nouvelle cartouche sélecteur
en laiton ECObrass à disques
en céramique autolubrifiants
en oxyde d'aluminium qui assurent
des mouvements souples et précis
au fil du temps



Monocomando

single-lever
monocommande



EASYpull

Deviatore meccanico, abbassando
il deviatore si ottiene la fuoriuscita
dell'acqua dalla doccia

*Mechanical diverter, the water
is supplied from the required outlet
by pulling down the diverter*

Sélecteur mécanique,
tirer le sélecteur vers le bas
pour obtenir la sortie douchette



ECOstop

Limita l'erogazione dell'acqua
con un risparmio fino al 50%

*Limits the flow of
water saving up to 50%*

Permet d'économiser
jusqu'à 50% d'eau



Guida alla lettura della simbologia

guide to reading the symbols
guide de lecture de la symbologie

tipologia prodotto
product type
type de produit



monocomando
single-lever
monocommande



termostatico
thermostatic
thermostatique

misura lavabo
basin-mixer size
mesure lavabo

- (S)
- regular (R)
- (M)
- (T)
- (XT)

risparmio d'acqua
fino al 50%

water saving
up to 50%
économie d'eau
jusqu'à 50%

risparmio energetico
energy saving
économie d'énergie

Sport plus

LAVABO E BIDET / BASIN AND BIDET / LAVABO ET BIDET



flessibili INOX antitorsione
connection hoses anti-twist
flexibles de raccordement antitorsion



SPL 72176 CR € 97,00

monocomando lavabo, scarico 1 1/4"
single-lever basin mixer, 1 1/4" pop-up waste
lavabo monocommande, vidage 1 1/4"

SPL 72176/S CR € 89,00

monocomando lavabo, senza scarico
single-lever basin mixer, without waste
lavabo monocommande, sans vidage



SPL 72276 CR € 104,00

monocomando lavabo, scarico 1 1/4"
single-lever basin mixer, 1 1/4" pop-up waste
lavabo monocommande, vidage 1 1/4"



SPL 72176 CR 034

SPL 72276 CR 030

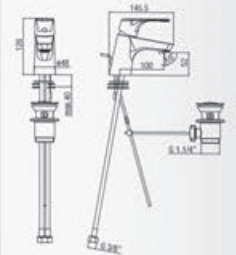

flessibili INOX antitorsione
connection hoses anti-twist
flexibles de raccordement antitorsion



SPL 72179 CR € 121,00

monocomando lavabo medio, scarico 1 1/4"
single-lever medium basin mixer, 1 1/4" pop-up waste
lavabo monocommande moyen, vidage 1 1/4"

SPL 72179/S CR € 113,00

monocomando lavabo medio, senza scarico
single-lever medium basin mixer, without waste
lavabo monocommande moyen, sans vidage



SPL 72279 CR € 129,00

monocomando lavabo medio, scarico 1 1/4"
single-lever medium basin mixer, 1 1/4" pop-up waste
lavabo monocommande moyen, vidage 1 1/4"



SPL 72179 CR 034

SPL 72279 CR 030

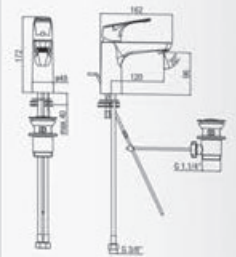

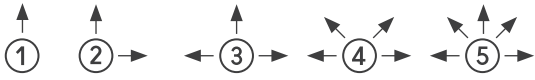

numero uscite miscelatore incasso
number of outlets concealed shower mixer
 nombre de sorties douche encastré

 cartuccia monocomando
single-lever cartridge
 cartouche monocommande

 cartuccia termostatica
thermostatic cartridge
 cartouche thermostatique

 vitone ceramico
ceramic headwork
 tête céramique

FINITURE FINISHES FINITIONS CR cromo | chrome | chromé |

SportPlus

 **SPL 72206 CR** € 244,00

termostatico vasca esterno
exposed thermostatic bath shower mixer
 bain douche thermostatique apparent

SPL 72206
 CR 010NC  CR-C3C

SPL 72106
 CR 010NC  CR-150C

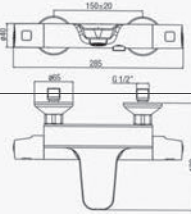

temperatura massima
 acqua calda 50°
*maximum temperature
 of hot water 50°*
 température maximale
 de l'eau chaude 50°

 **SPL 72106 CR** € 234,00

termostatico vasca esterno
exposed thermostatic bath shower mixer
 bain douche thermostatique apparent

corpo freddo
anti-scald
 corp froid

SOLUZIONI INCASSO DOCCIA / VASCA SHOWER / BATH CONCEALED SOLUTIONS SOLUTIONS ENCASTRÉES DOUCHE / BAIN



SPL 72A863 CR € 125,00

parte incasso compresa
built-in mixer body included
 boîtier d'encastrement fourni

 ECOstop

 CR 035

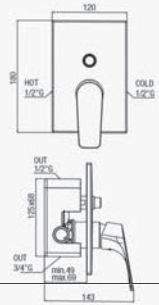

numero pezzi per master
number of pieces for master
 nombre de pièces pour master



SPL 72A863 CR € 125,00

parte incasso compresa
built-in mixer body included
 boîtier d'encastrement fourni

 ECOstop

 CR 035

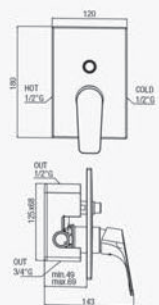

Sport Plus



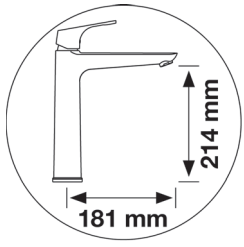

size



flessibili INOX antitorsione
connection hoses anti-twist
flexibles de raccordement antitorsion



SPL 72177/S CR € 212,00

monocomando lavabo alto, senza scarico
single-lever tall basin mixer, without waste
lavabo monocommande haut, sans vidage



SC 010 CR € 25,00

scarico click-clack
click-clack waste
vidage click-clack



CR 005

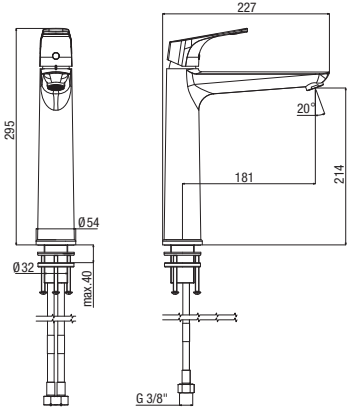

parte incasso compresa
built-in mixer body included
boîtier d'encastrement fourni



SPL 72876 CR € 278,00

monocomando lavabo incasso
concealed single-lever basin mixer
lavabo mural monocommande



CR 023

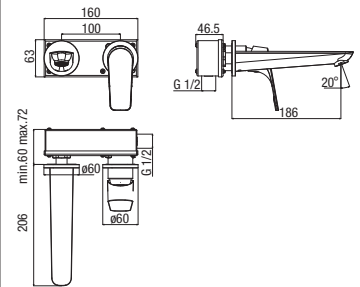

flessibili INOX antitorsione
connection hoses anti-twist
flexibles de raccordement antitorsion



ECOstop

SPL 72221 CR € 97,00

monocomando bidet, scarico 1 1/4"
single-lever bidet mixer, 1 1/4" pop-up waste
bidet monocommande, vidage 1 1/4"

SPL 7221/S CR € 89,00

monocomando bidet, senza scarico
single-lever bidet mixer, without waste
bidet monocommande, sans vidage



C3



ECOstart

SPL 72321 CR € 104,00

monocomando bidet, scarico 1 1/4"
single-lever bidet mixer, 1 1/4" pop-up waste
bidet monocommande, vidage 1 1/4"



SPL 72221 CR 034

SPL 72321 CR 030

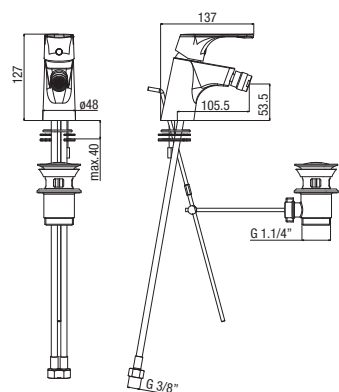

Sport plus

CUCINA SINK EVIER



SPL 72282 CR

€ 116,00

monocomando lavello
single-lever sink mixer
évier monocommande



SPL 72382 CR

€ 123,00



monocomando lavello
single-lever sink mixer
évier monocommande

SPL 72282  CR 035

SPL 72382  CR 029

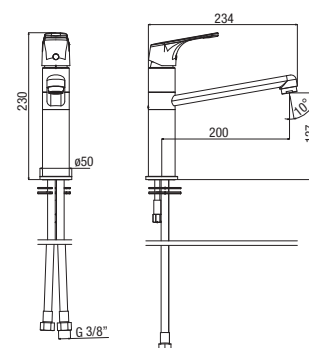

SPL 72383 CR

€ 95,00

monocomando lavello
single-lever sink mixer
évier monocommande

 CR 035

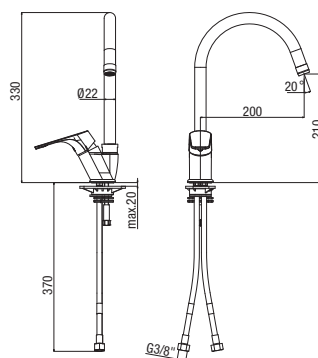

SPL 72283 CR

€ 102,00

monocomando lavello
single-lever sink mixer
évier monocommande

 CR 035

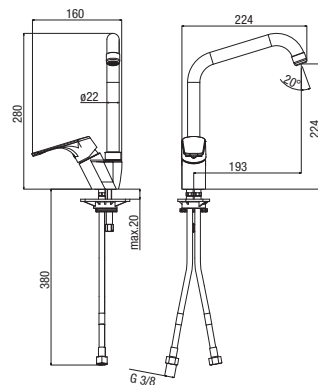

SPL 72250 CR

€ 121,00

monocomando lavello
single-lever sink mixer
évier monocommande

 CR 034

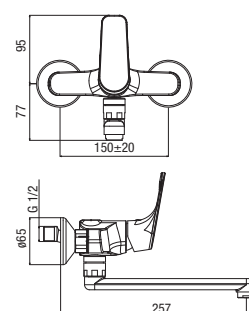



SPL 72852 CR

€ 196,00

monocomando lavatoio completo di kit doccia,
flessibile doccia PVC e doccia monogetto anticalcare
*single-lever laundry mixer complete with shower kit,
shower hose PVC and one spray handset anti-scale*

monocommande pour lavoit avec kit de douche,
flexible de douche PVC et douchette monojet anticalcaire

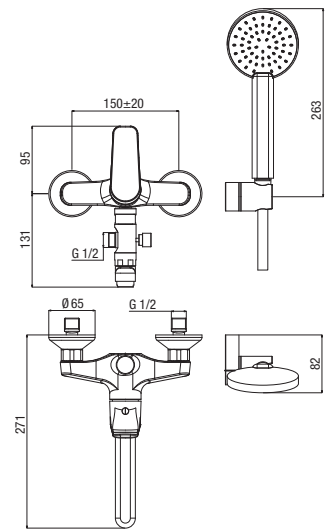

SPL 72252 CR

€ 251,00

termostatico lavatoio completo di kit doccia,
flessibile doccia PVC e doccia monogetto anticalcare
*thermostatic laundry mixer complete with shower kit,
shower hose PVC and one spray handset anti-scale*

thermostatique pour lavoit avec kit de douche,
flexible de douche PVC et douchette monojet anticalcaire

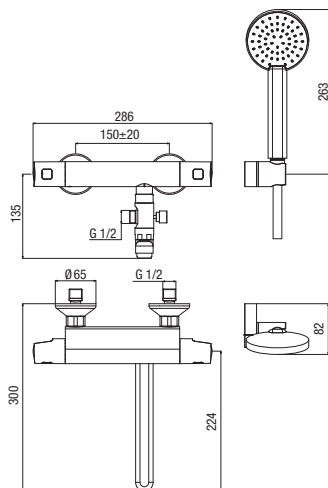

SPL 72150 CR

€ 176,00

termostatico lavello a muro
thermostatic sink mixer
évier thermostatique

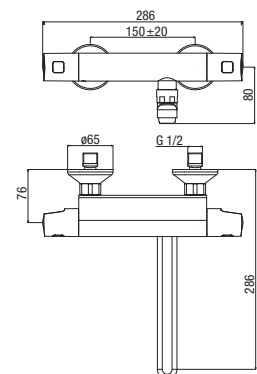

Sport plus

COLONNE DOCCIA SHOWER COLUMNS COLONNES DE DOUCHE

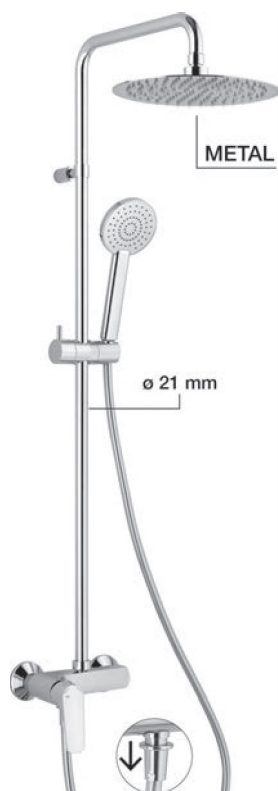

Il tubo della colonna doccia può essere tagliato
the riser of the shower column can be cut
 le tube de la colonne de douche peut être coupée



SPL 96RM2251 CR

€ 472,00

colonna doccia monocomando
 - deviatore meccanico **EASYpull**
 - soffione ø 250 mm
 - doccia monogetto anticalcare
 con sistema **AIRmix**

single-lever shower column
 - *mechanical diverter EASYpull*
 - *ø 250 mm shower head*
 - *one spray handset anti-scale*
 with **AIRmix** saving system

colonne de douche monocommande
 - inverseur mécanique **EASYpull**
 - pomme de douche ø 250 mm
 - douchette monojet anticalcaire
 avec système **AIRmix**

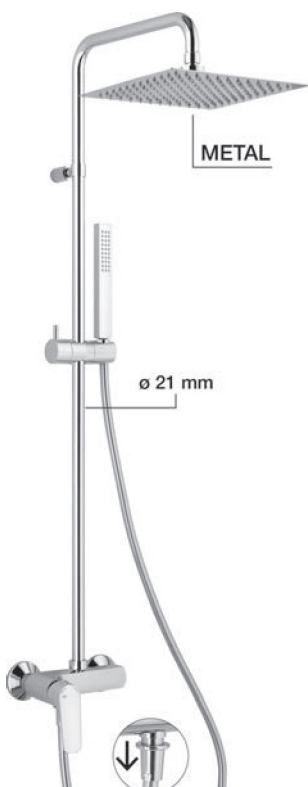
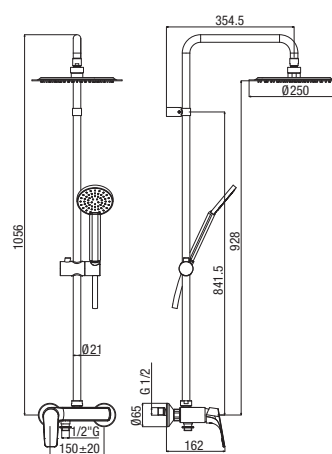

Il tubo della colonna doccia può essere tagliato
the riser of the shower column can be cut
 le tube de la colonne de douche peut être coupée



SPL 96SM2251 CR

€ 501,00

colonna doccia monocomando
 - deviatore meccanico **EASYpull**
 - soffione 250x250 mm
 - doccia monogetto anticalcare

single-lever shower column
 - *mechanical diverter EASYpull*
 - *250x250 mm shower head*
 - *one spray handset anti-scale*

colonne de douche monocommande
 - inverseur mécanique **EASYpull**
 - pomme de douche 250x250 mm
 - douchette monojet anticalcaire

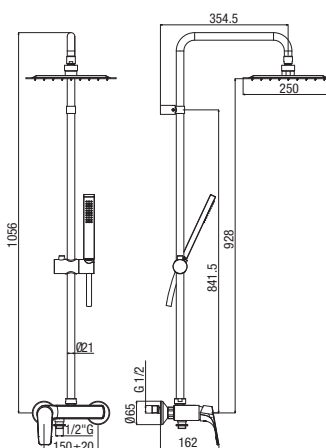



SPL 96RP7251 CR

€ 513,00

colonna doccia monocomando

- **telescopica**
- deviatore meccanico **EASYpull**
- soffione ø 200 mm
- doccia monogetto anticalcare con sistema **AIRmix**

single-lever shower column

- **adjustable**
- mechanical diverter **EASYpull**
- ø 200 mm shower head
- one spray handset anti-scale with **AIRmix** saving system

colonne de douche monocommande

- **télescopique**
- inverseur mécanique **EASYpull**
- pomme de douche ø 200 mm
- douchette monojet anticalcaire avec système **AIRmix**



CR 034

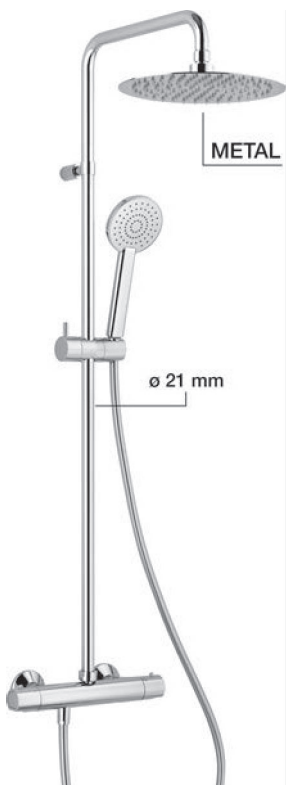
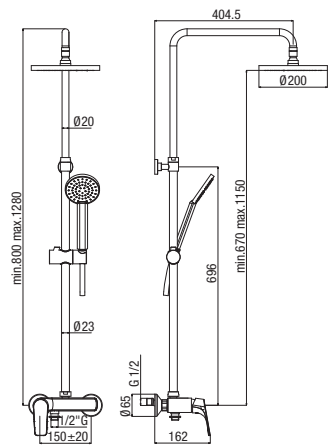

METAL

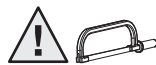

Il tubo della colonna doccia può essere tagliato
the riser of the shower column can be cut
le tube de la colonne de douche peut être coupée



SPL 96RM2151 CR

€ 555,00

colonna doccia termostatica

- deviazione integrata
- soffione ø 250 mm
- doccia monogetto anticalcare con sistema **AIRmix**

thermostatic shower column

- integrated diverter
- ø 250 mm shower head
- one spray handset anti-scale with **AIRmix** saving system

colonne de douche thermostatique

- inverseur intégré
- pomme de douche ø 250 mm
- douchette monojet anticalcaire avec système **AIRmix**



VT 002



CR-150C

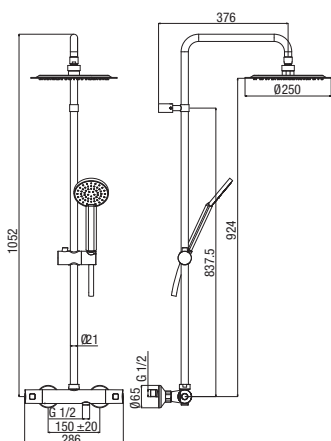

Sport plus

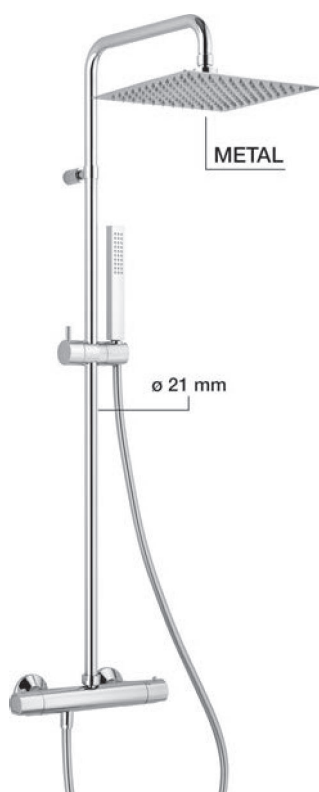

Il tubo della colonna doccia può essere tagliato
the riser of the shower column can be cut
 le tube de la colonne de douche peut être coupée



SPL 96SM2151 CR

€ 585,00

colonna doccia termostatica
 - deviatore meccanico
 - soffione 250x250 mm
 - doccia monogetto anticalcare

thermostatic shower column
 - *mechanical diverter*
 - *250x250 mm shower head*
 - *one spray handset anti-scale*

colonne de douche thermostatique
 - inverseur mécanique
 - pomme de douche 250x250 mm
 - douchette monojet anticalcaire

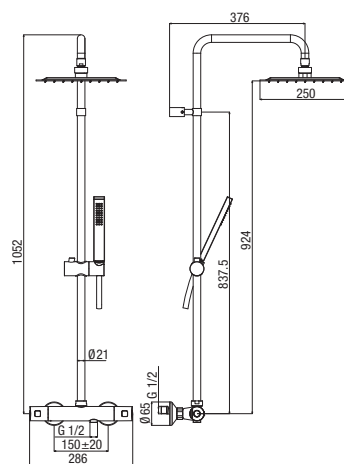

SPL 72RP7151 CR

€ 534,00

colonna doccia termostatica
 - **telescopica**
 - deviazione integrata
 - soffione ø 200 mm
 - doccia monogetto anticalcare
 con sistema **AIRmix**

thermostatic shower column
 - **adjustable**
 - *integrated diverter*
 - *ø 200 mm shower head*
 - *one spray handset anti-scale*
 with **AIRmix** saving system

colonne de douche thermostatique
 - **téléscopique**
 - inverseur intégré
 - pomme de douche ø 200 mm
 - douchette monojet anticalcaire
 avec système **AIRmix**

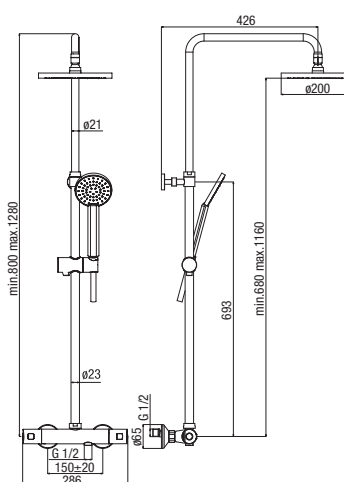

SOLUZIONI ESTERNO DOCCIA / VASCA SHOWER / BATH EXPOSED SOLUTIONS SOLUTIONS APPARENTES DOUCHE / BAIN



SPL 72855 CR

€ 101,00

monocomando doccia esterno
exposed single-lever shower mixer
 douche apparent monocommande



CR 034

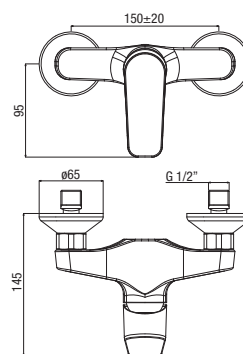

SPL 72855/153 CR

€ 128,00

monocomando doccia esterno, interasse 153 mm
exposed single-lever shower mixer, inlets distance 153 mm
 douche apparent monocommande, entraxe 153 mm

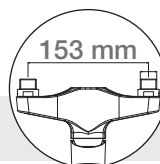

CR 034

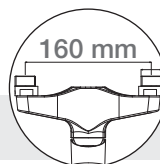

SPL 72855/160 CR

€ 128,00

monocomando doccia esterno, interasse 160 mm
exposed single-lever shower mixer, inlets distance 160 mm
 douche apparent monocommande, entraxe 160 mm

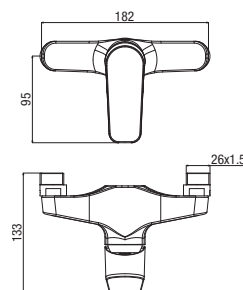

SPL 72801 CR

€ 190,00

monocomando vasca esterno con supporto doccia snodato,
 flessibile doccia PVC e doccia monogetto
 anticalcare con sistema **AIRmix**
*exposed single-lever bath shower mixer with adjustable
 shower bracket, shower hose PVC, and one spray
 anti-scale handset with AIRmix saving system*
 bain douche apparent monocommande avec support
 douchette réglable, flexible de douche PVC et douchette
 monojet anticalcaire avec système **AIRmix**

SPL 72806 CR

€ 138,00

monocomando vasca esterno senza set doccia
exposed single-lever bath shower mixer without handset kit
 bain douche apparent monocommande sans kit de douche



CR 039

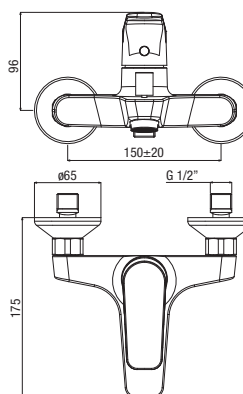

Sport plus

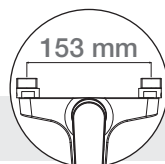

SPL 72806/153 CR

€ 163,00



monocomando vasca esterno, interasse 153 mm
exposed single-lever bath shower mixer, inlets distance 153 mm
 bain douche apparent monocommande, entraxe 153 mm

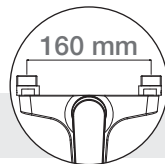

SPL 72806/160 CR

€ 163,00



monocomando vasca esterno, interasse 160 mm
exposed single-lever bath shower mixer, inlets distance 160 mm
 bain douche apparent monocommande, entraxe 160 mm



CR 039

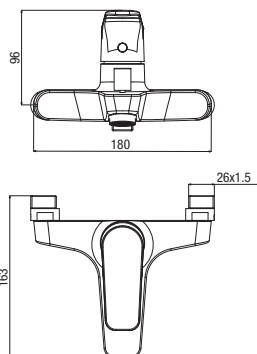

SPL 72808 CR

€ 147,00



monocomando bordo vasca
single-lever deck bath shower mixer
 bain douche monocommande monotrou sur gorge



CR 039

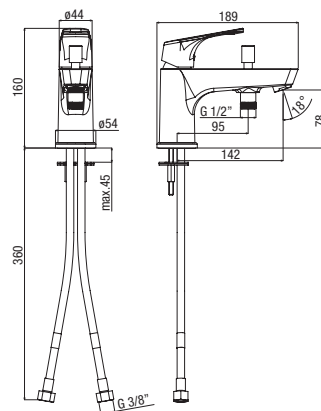

SPL 72255 CR

€ 169,00



termostatico doccia esterno
exposed thermostatic shower mixer
 douche thermostatique apparent



SPL 72155 CR

€ 159,00



termostatico doccia esterno
exposed thermostatic shower mixer
 douche thermostatique apparent



VT 002



CR-C3C

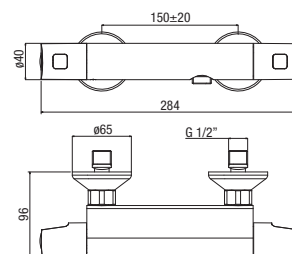



SPL 72155/153 CR € 182,00

5 master
 termostatico doccia esterno, interasse 153 mm
exposed thermostatic shower mixer, inlets distance 153 mm
 douche thermostatique apparent, entraxe 153 mm

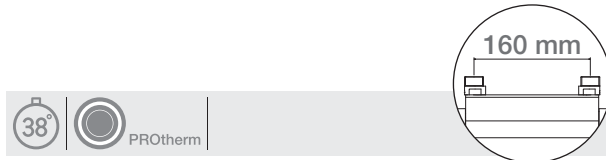

SPL 72155/160 CR € 182,00

5 master
 termostatico doccia esterno, interasse 160 mm
exposed thermostatic shower mixer, inlets distance 160 mm
 douche thermostatique apparent, entraxe 160 mm

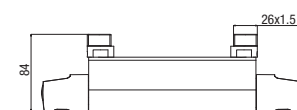
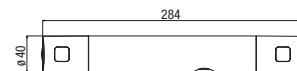
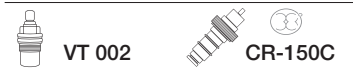

SPL 72206 CR € 244,00

5 master
 termostatico vasca esterno
exposed thermostatic bath shower mixer
 bain douche thermostatique apparent

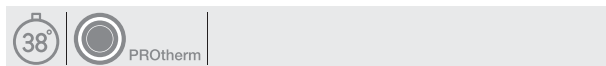

SPL 72106 CR € 234,00

5 master
 termostatico vasca esterno
exposed thermostatic bath shower mixer
 bain douche thermostatique apparent

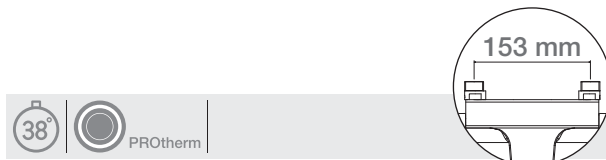
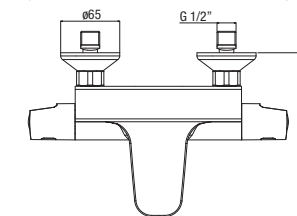
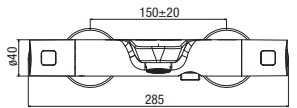
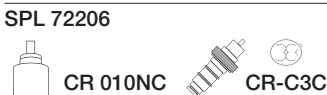

SPL 72106/153 CR € 258,00

5 master
 termostatico vasca esterno, interasse 153 mm
exposed thermostatic bath shower mixer, inlets distance 153 mm
 bain douche thermostatique apparent, entraxe 153 mm

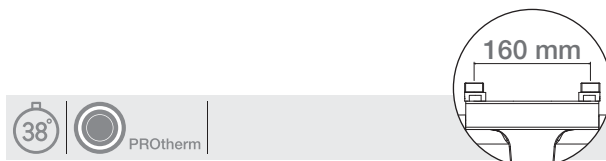

SPL 72106/160 CR € 258,00

5 master
 termostatico vasca esterno, interasse 160 mm
exposed thermostatic bath shower mixer, inlets distance 160 mm
 bain douche thermostatique apparent, entraxe 160 mm

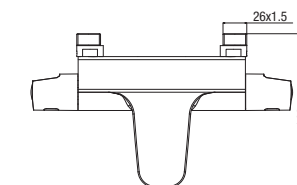
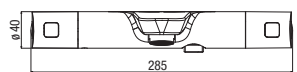
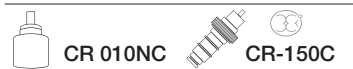

Sport plus

SOLUZIONI INCASSO DOCCIA / VASCA SHOWER / BATH CONCEALED SOLUTIONS SOLUTIONS ENCASTRÉES DOUCHE / BAIN



SPL 72A861 CR

€ 64,00



monocomando doccia incasso, piastra **ABS**
concealed single-lever shower mixer, ABS plate
 douche encastré monocommande, plaque **ABS**



CR 035

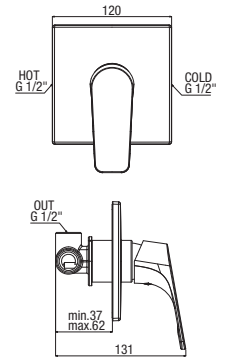

parte incasso compresa
built-in mixer body included
 boîtier d'encastrement fourni



SPL 72A863 CR

€ 125,00



monocomando doccia incasso con deviatore meccanico,
 piastra **ABS**
concealed single-lever shower mixer with mechanical diverter, ABS plate
 douche encastré monocommande avec inverseur mécanique,
 plaque **ABS**



CR 035

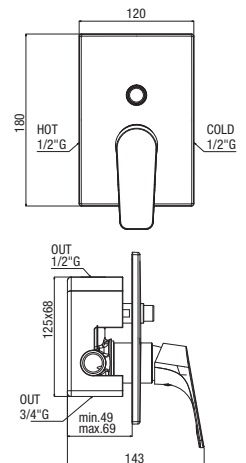

parte incasso compresa
built-in mixer body included
 boîtier d'encastrement fourni



SPL 72161 CR

€ 314,00



termostatico doccia incasso con rubinetto regolazione portata
concealed thermostatic shower valve with stop cock
 douche thermostatique encastré avec robinet d'arrêt



VT 002



CR-107C

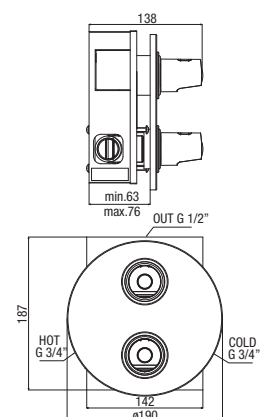



parte incasso compresa
built-in mixer body included
 boîtier d'encastrement fourni

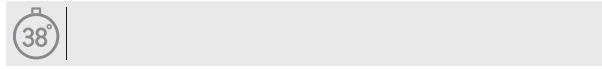

SPL 72163 CR € 405,00

termostatico doccia incasso con deviatore ceramico
due uscite e regolazione portata
concealed thermostatic shower valve with
two outlets ceramic diverter and stop



douche thermostatique encastré avec sélecteur
 céramique **deux sorties** et réglage débit

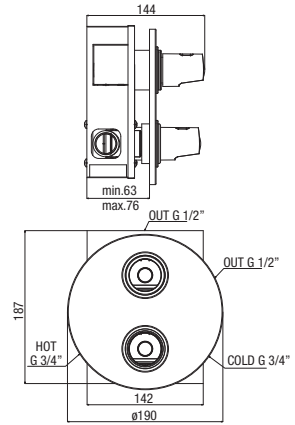

City Plus



City plus

LAVABO E BIDET *BASIN AND BIDET* LAVABO ET BIDET

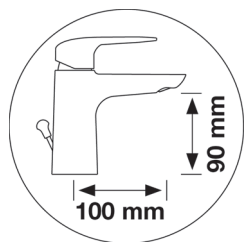

size **R**



CPL 87276 CR € 99,00

monocomando lavabo, scarico 1 1/4"
single-lever basin mixer, 1 1/4" pop-up waste
lavabo monocommande, vidage 1 1/4"

CPL 87276/S CR € 91,00

monocomando lavabo, senza scarico
single-lever basin mixer, without waste
lavabo monocommande, sans vidage



ECOstart

CPL 87376 CR € 104,00

monocomando lavabo, scarico 1 1/4", sistema **ECOstart**
single-lever basin mixer, 1 1/4" pop-up waste,
ECOstart saving system



lavabo monocommande, vidage 1 1/4", système **ECOstart**

CPL 87276  CR 005

CPL 87376  CR 030

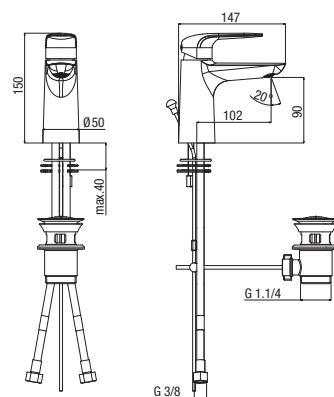

 CR 005

 CR 030

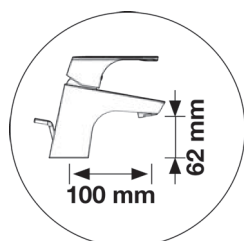

size **R**



CPL 87176 CR € 94,00

monocomando lavabo, scarico 1 1/4"
single-lever basin mixer, 1 1/4" pop-up waste
lavabo monocommande, vidage 1 1/4"

CPL 87176/S CR € 86,00

monocomando lavabo, senza scarico
single-lever basin mixer, without waste
lavabo monocommande, sans vidage



ECOstart

CPL 87476 CR € 99,00

monocomando lavabo, scarico 1 1/4", sistema **ECOstart**
single-lever basin mixer, 1 1/4" pop-up waste,
ECOstart saving system



lavabo monocommande, vidage 1 1/4", système **ECOstart**

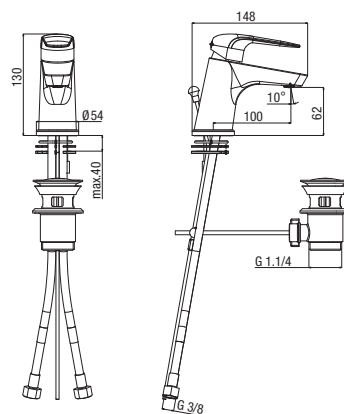

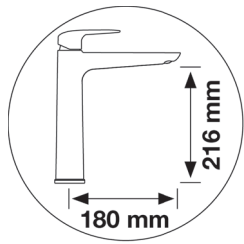

size T

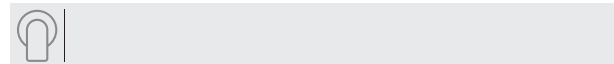

CPL 87277/S CR € 202,00

monocomando lavabo alto, senza scarico
single-lever tall basin mixer, without waste
 lavabo monocommande haut, sans vidage



SC 010 CR € 25,00

scarico click-clack
click-clack waste
 vidage click-clack

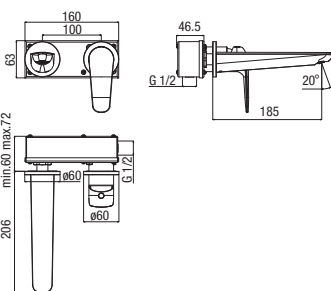
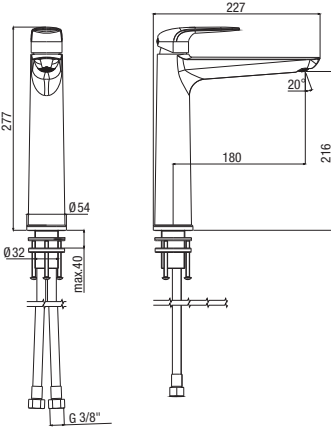

parte incasso compresa
built-in mixer body included
 boîtier d'encastrement fourni

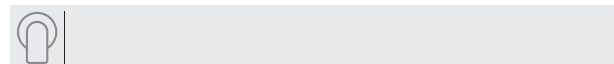

CPL 87876 CR € 278,00

monocomando lavabo incasso
concealed single-lever basin mixer
 lavabo mural monocommande

CPL 87201 CR 005

CPL 87301 CR 030

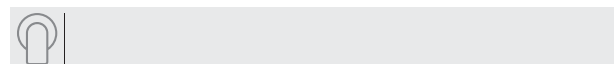

CPL 87201 CR € 92,00

monocomando bidet, scarico 1 1/4"
single-lever bidet mixer, 1 1/4" pop-up waste
 bidet monocommande, vidage 1 1/4"

CPL 87201/S CR € 84,00



monocomando bidet, senza scarico
single-lever bidet mixer, without waste
 bidet monocommande, sans vidage

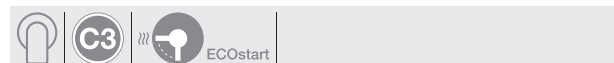

CPL 87301 CR € 97,00

monocomando bidet, scarico 1 1/4", sistema **ECOstart**
single-lever bidet mixer, 1 1/4" pop-up waste, ECOstart saving system
 bidet monocommande, vidage 1 1/4", système **ECOstart**

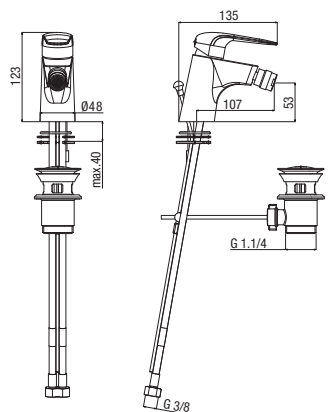

City plus

CUCINA SINK EVIER



CPL 87282 CR

€ 89,00



monocomando lavello, bocca girevole
single lever sink mixer, swivel spout
évier monocommande, bec orientable



ECOstart

CPL 87382 CR

€ 93,00



monocomando lavello, bocca girevole, sistema **ECOstart**
single lever sink mixer, swivel spout,
ECOstart saving system
évier monocommande, bec orientable, système **ECOstart**



CPL 87282 CR 023

CPL 87382 CR 029

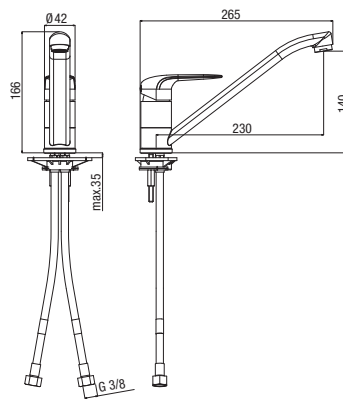

CPL 87283 CR

€ 100,00



monocomando lavello, bocca girevole
single lever sink mixer, swivel spout
évier monocommande, bec orientable



CR 023

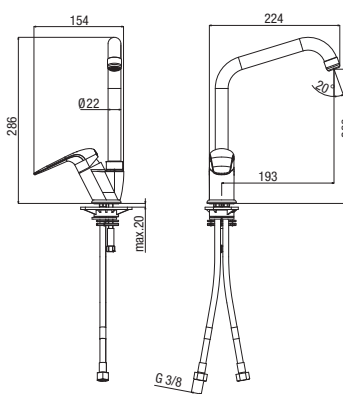

CPL 87250 CR

€ 117,00



monocomando lavello a muro,
rosconi con eccentrici rinforzati **"FIX LONG"**
exposed wall-mounted single lever sink mixer,
flanges and reinforced s-union "FIX LONG"
évier mural monocommande apparent,
rosaces et raccords excentriques renforcés **"FIX LONG"**



CR 005

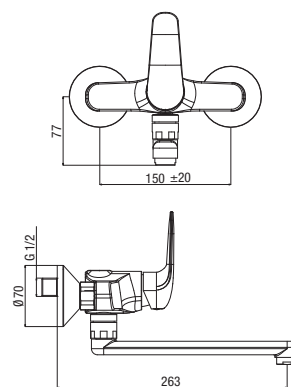

COLONNE DOCCIA SHOWER COLUMNS COLONNES DE DOUCHE

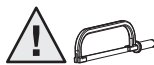
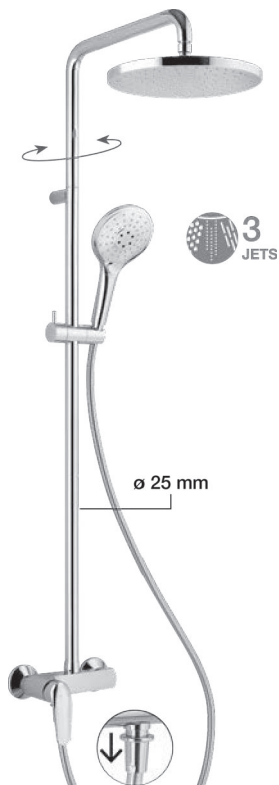

Il tubo della colonna doccia può essere tagliato
the riser of the shower column can be cut
 le tube de la colonne de douche peut être coupée



CPL 87RP2251 CR

€ 459,00

- colonna doccia monocomando
- tubo doccia tagliabile e orientabile
 - deviatore meccanico **EASYPull**
 - soffione ø 250 mm
 - doccia **tre getti** anticalcare a pulsante
 - flessibile doccia PVC
 - rosconi con eccentrici rinforzati **"FIX LONG"**
- single-lever shower column*
- *cuttable and swivelling shower pipe*
 - *mechanical diverter **EASYPull***
 - *ø 250 mm shower head*
 - ***three sprays** anti-scale handset with press button*
 - *shower hose PVC*
 - *flanges and reinforced s-union **"FIX LONG"***

- colonne de douche monocommande
- tube de la colonne cuttable et pivotant
 - inverseur mécanique **EASYPull**
 - pomme de douche ø 250 mm
 - douchette anticalcaire **trois jets**, sélection à bouton
 - flexible de douche PVC
 - rosaces et raccords excentriques renforcés **"FIX LONG"**



CR 005

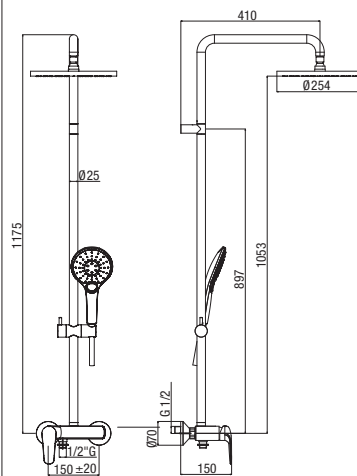

Il tubo della colonna doccia può essere tagliato
the riser of the shower column can be cut
 le tube de la colonne de douche peut être coupée



CPL 87SP2251 CR

€ 489,00

- colonna doccia monocomando
- tubo doccia tagliabile e orientabile
 - deviatore meccanico **EASYPull**
 - soffione 250x250 mm
 - doccia **tre getti** anticalcare a pulsante
 - flessibile doccia PVC
 - rosconi con eccentrici rinforzati **"FIX LONG"**
- single-lever shower column*
- *cuttable and swivelling shower pipe*
 - *mechanical diverter **EASYPull***
 - *250x250 mm shower head*
 - ***three sprays** anti-scale handset with press button*
 - *shower hose PVC*
 - *flanges and reinforced s-union **"FIX LONG"***

- colonne de douche monocommande
- tube de la colonne cuttable et pivotant
 - inverseur mécanique **EASYPull**
 - pomme de douche 250x250 mm
 - douchette anticalcaire **trois jets**, sélection à bouton
 - flexible de douche PVC
 - rosaces et raccords excentriques renforcés **"FIX LONG"**



CR 005

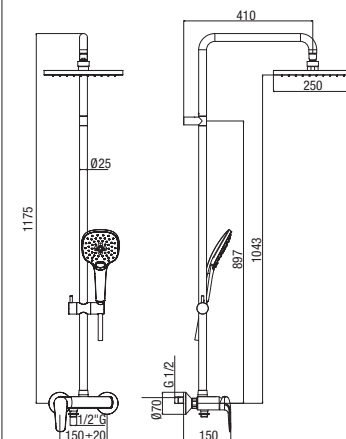

City plus



Il tubo della colonna doccia può essere tagliato
the riser of the shower column can be cut
 le tube de la colonne de douche peut être coupée



CPL 87RP2151 CR € 496,00

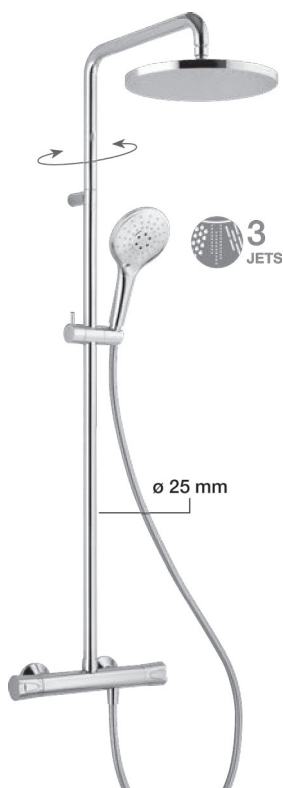

- colonna doccia termostatica
- tubo doccia tagliabile e orientabile
 - deviazione integrata
 - soffione ø 250 mm
 - doccia **tre getti** anticalcare a pulsante
 - flessibile doccia PVC
 - rosoni con eccentrici rinforzati **"FIX LONG"**

thermostatic shower column

- *cuttable and adjustable shower pipe*
- *integrated diverter*
- *ø 250 mm shower head*
- *three sprays anti-scale handset with press button*
- *shower hose PVC*
- *flanges and reinforced s-union "FIX LONG"*

colonne de douche thermostatique

- tube de la colonne cuttable et orientable
- inverseur intégré

- pomme de douche ø 250 mm
- douchette anticalcaire **trois jets**, sélection à bouton
- flexible de douche PVC
- rosaces et raccords excentriques renforcés **"FIX LONG"**

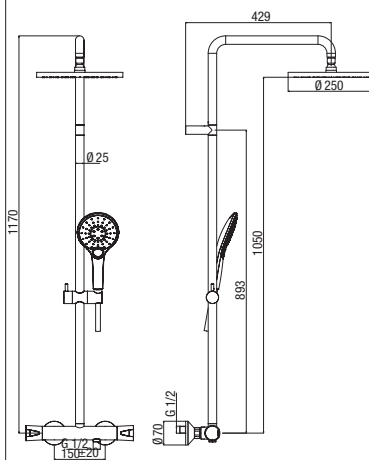

Il tubo della colonna doccia può essere tagliato
the riser of the shower column can be cut
 le tube de la colonne de douche peut être coupée



CPL 87SP2151 CR € 526,00

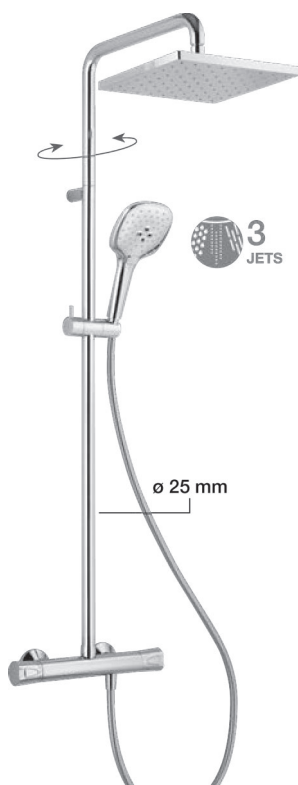

- colonna doccia termostatica
- tubo doccia tagliabile e orientabile
 - deviazione integrata
 - soffione 250x250 mm
 - doccia **tre getti** anticalcare a pulsante
 - flessibile doccia PVC
 - rosoni con eccentrici rinforzati **"FIX LONG"**

thermostatic shower column

- *cuttable and adjustable shower pipe*
- *integrated diverter*
- *250x250 mm shower head*
- *three sprays anti-scale handset with press button*
- *shower hose PVC*
- *flanges and reinforced s-union "FIX LONG"*

colonne de douche thermostatique

- tube de la colonne cuttable et orientable
- inverseur intégré

- pomme de douche 250x250 mm
- douchette anticalcaire **trois jets**, sélection à bouton
- flexible de douche PVC
- rosaces et raccords excentriques renforcés **"FIX LONG"**

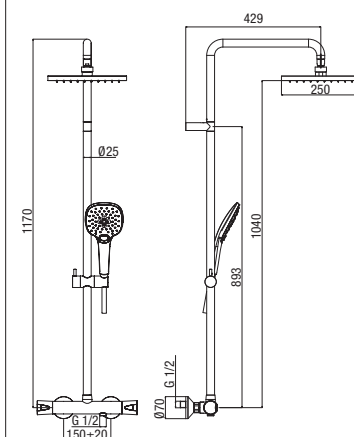



ideale per spazi ridotti
ideal for small spaces
idéal pour les espaces petits



ECI 75RP2151 CR

€ 641,00

- colonna doccia termostatica
- deviazione integrata
 - soffione ø 200 mm
 - doccia monogetto con sistema **AIRmix**
- thermostatic shower column
- integrated diverter
 - 200 mm shower head
 - one spray handset **AIRmix** saving system
- colonne de douche thermostatique
- inverseur intégré
 - pomme de douche ø 200 mm
 - douchette monojet avec système **AIRmix**

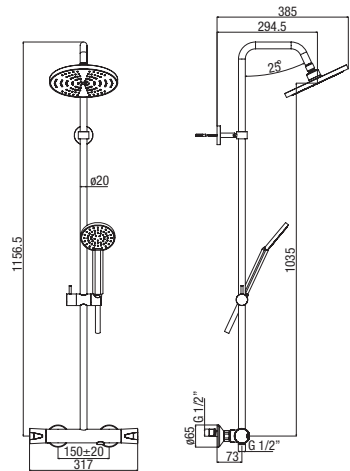
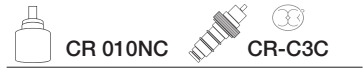

La lunghezza del braccio doccia è contenuta per ottimizzare lo spazio ridotto disponibile.

The length of the shower arm is reduced to optimize the small space available.

La longueur du bras douche est contenue pour optimiser l'espace réduit disponible.



City plus



ideale per trasformazione da vasca in doccia
ideal for transformation from bathroom into shower
 idéal pour la transformation de la baignoire à la douche



Il tubo della colonna doccia può essere tagliato
the riser of the shower column can be cut
 le tube de la colonne de douche peut être coupée



JO 74RP3151 CR

€ 528,00

colonna doccia termostatica con asta prolungata
 ideale per ristrutturazione

- deviazione integrata
- soffione ø 200 mm
- doccia monogetto anticalcare

*thermostatic shower column with longer shower pipe
 ideal for renovation*

- integrated diverter
- ø 200 mm shower head
- one spray anti-scale handset

colonne de douche thermostatique avec tube plus long
 idéal pour la rénovation

- inverseur intégré
- pomme de douche ø 200 mm
- douchette monojet anticalcaire

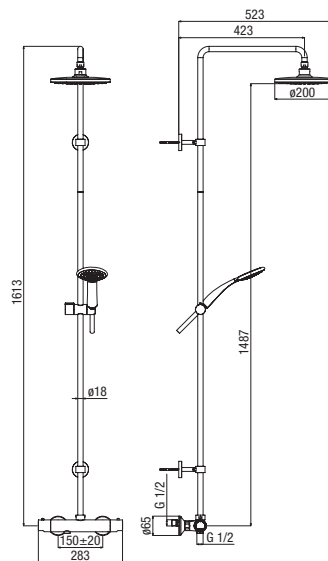

Sfruttando i **vecchi attacchi acqua** otteniamo l'altezza ottimale del soffione doccia grazie al riser più lungo degli standard (normalmente una colonna doccia è alta 110 cm e viene posizionata a 120 cm)

Using **the previous water connections** we obtain the optimal height of the shower head thanks to the riser longer than standard ones (usually a shower column is 110 cm tall and is positioned at 120 cm).

Utilisant **les anciennes connexions eau** on obtient la hauteur optimale de la pomme de douche grâce au riser plus long par rapport à celui standard (normalement une colonne douche est haute 110 cm et est positionnée à 120 cm).

prima before avant

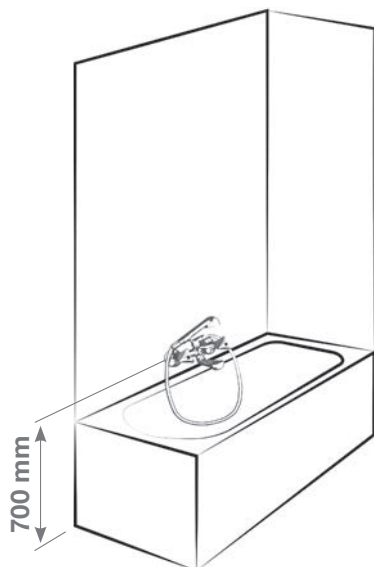

dopo after après

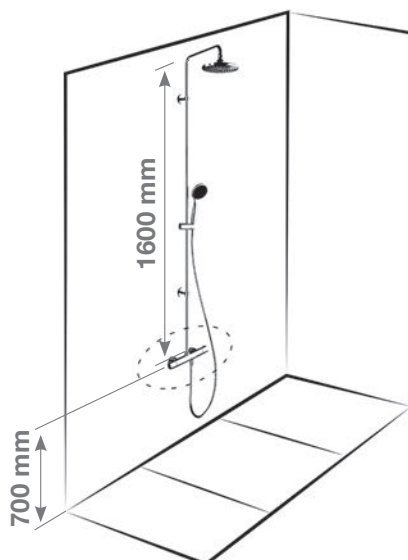



vasca/doccia
bath&shower
bain&douche

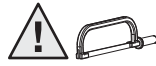

Il tubo della colonna doccia può essere tagliato
the riser of the shower column can be cut
le tube de la colonne de douche peut être coupée



CPL 87RM4151 CR

€ 790,00

colonna vasca/doccia termostatica

- deviazione integrata
- soffione ø 200 mm
- doccia monogetto anticalcare

thermostatic bath&shower column

- integrated diverter
- ø 200 mm shower head
- one spray anti-scale handset

colonne thermostatique bain&douche

- inverseur intégré
- pomme de douche ø 200 mm
- douchette monojet anticalcaire

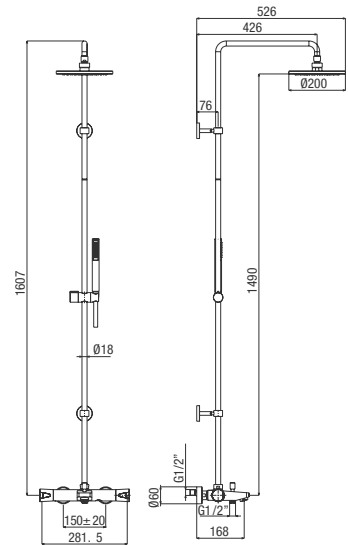

Sostituendo il vecchio gruppo vasca con la colonna vasca/doccia termostatica si aumenta il comfort in quanto si hanno a disposizione 3 uscite acqua con il soffione doccia ø 200 mm.

Replacing the previous bath shower mixer with the thermostatic bath&shower column comfort is enhanced since there are 3 water outlets available with shower head ø 200 mm.

En remplaçant l'ancien bain douche avec la colonne thermostatique bain&douche le confort augmente car on a 3 sorties eau disponibles avec la pomme de douche ø 200 mm.

prima before avant

dopo after après

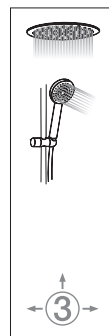
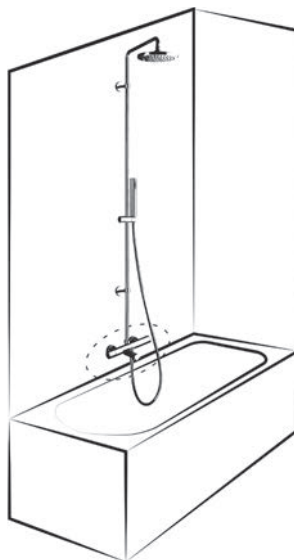
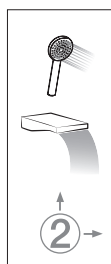
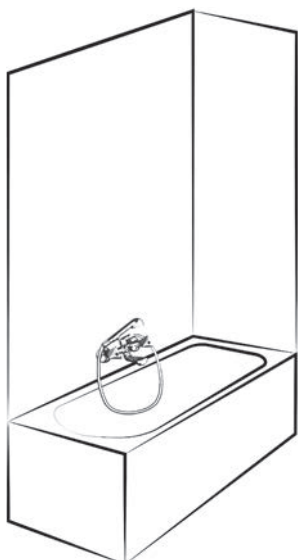



CPL 87855 CR

€ 102,00

monocomando doccia esterno,
rosoni con eccentrici rinforzati **"FIX LONG"**
exposed single-lever shower mixer,
flanges and reinforced s-union "FIX LONG"
douche apparent monocommande rosaces et
raccords excentriques renforcés **"FIX LONG"**



CR 005

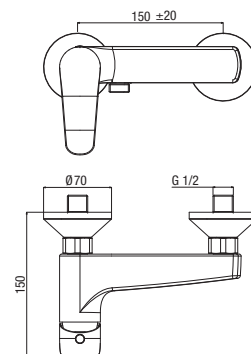

Il tubo della colonna doccia può essere tagliato
the riser of the shower column can be cut
le tube de la colonne de douche peut être coupée



CPL 87851 CR

€ 236,00

monocomando doccia esterno, kit saliscendi integrato
con doccia **tre getti** anticalcare a pulsante,
rosoni con eccentrici rinforzati **"FIX LONG"**
exposed single-lever shower mixer, integrated slide rail kit
*with **three sprays** anti-scale handset with press button,*
flanges and reinforced s-union "FIX LONG"
douche apparent monocommande, kit barre de douche intégré
avec douchette anticalcaire **trois jets**, sélection à bouton,
rosaces et raccords excentriques renforcés **"FIX LONG"**



CR 005

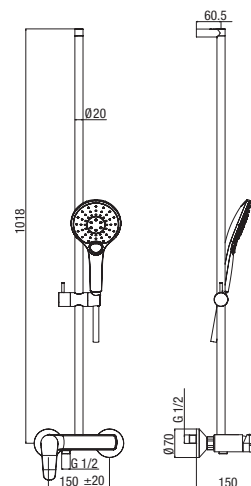

CPL 87801 CR

€ 186,00

monocomando vasca esterno con supporto doccia snodato,
flessibile doccia PVC e doccia **tre getti** anticalcare a pulsante,
rosoni con eccentrici rinforzati **"FIX LONG"**
exposed single-lever bath shower mixer with adjustable
*shower bracket, shower hose PVC and **three sprays***
anti-scale handset with press button flanges
and reinforced s-union "FIX LONG"

bain douche apparent monocommande avec support douchette
réglable, flexible de douche PVC et douchette anticalcaire
trois jets, sélection à bouton, rosaces et raccords
excentriques renforcés **"FIX LONG"**

CPL 87806 CR

€ 133,00

monocomando vasca esterno senza set doccia
exposed single-lever bath shower mixer without handset kit
bain douche apparent monocommande sans kit de douche



CR 005

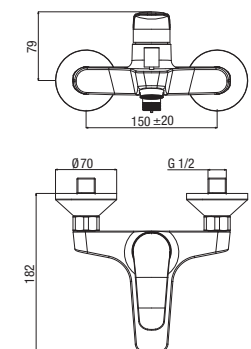

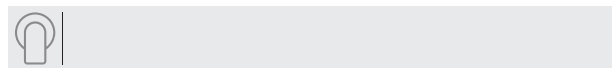

CPL 87808 CR € 139,00

monocomando bordo vasca
single-lever deck bath shower mixer
 bain douche monocommande monotrou sur gorge



CR 039

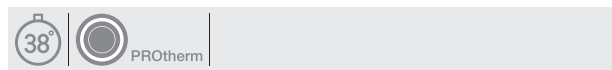
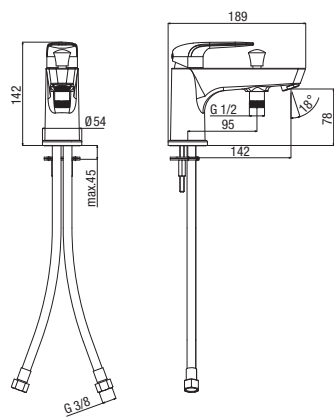

CPL 87155 CR € 187,00

termostatico doccia esterno,
 rosoni con eccentrici rinforzati **"FIX LONG"**
exposed thermostatic shower mixer,
flanges and reinforced s-union "FIX LONG"
 douche thermostatique apparent,
 rosaces et raccords excentriques renforcés **"FIX LONG"**



VT 002



CR-150C

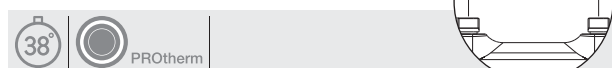
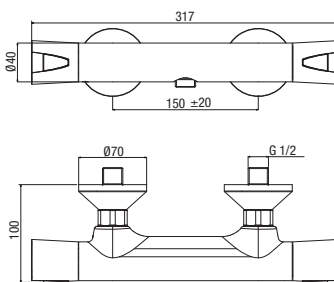

CPL 87155/153 CR € 212,00

termostatico doccia esterno, interasse 153 mm
exposed thermostatic shower mixer, inlets distance 153 mm
 douche thermostatique apparent, entraxe 153 mm



VT 002



CR-150C

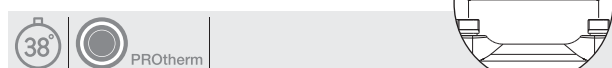
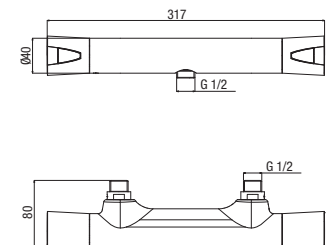
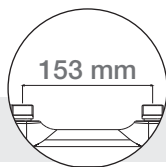

CPL 87155/160 CR € 212,00

termostatico doccia esterno, interasse 160 mm
exposed thermostatic shower mixer, inlets distance 160 mm
 douche thermostatique apparent, entraxe 160 mm

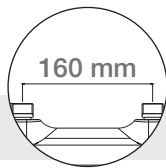

City plus



Il tubo della colonna doccia può essere tagliato
the riser of the shower column can be cut
 le tube de la colonne de douche peut être coupée



CPL 87151 CR € 302,00

termostatico doccia esterno, kit saliscendi integrato con doccia **tre getti** anticalcare a pulsante, rosoni con eccentrici rinforzati **"FIX LONG"**
exposed thermostatic shower mixer, integrated slide rail kit with three sprays anti-scale handset with press button, flanges and reinforced s-union "FIX LONG"



douche thermostatique apparent, kit barre de douche intégré avec douchette anticalcaire **trois jets**, sélection à bouton, rosaces et raccords excentriques renforcés **"FIX LONG"**

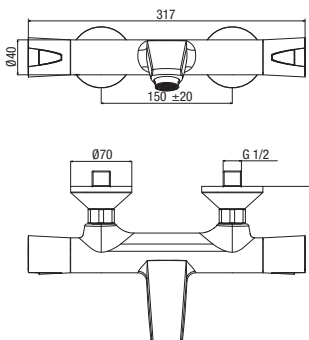
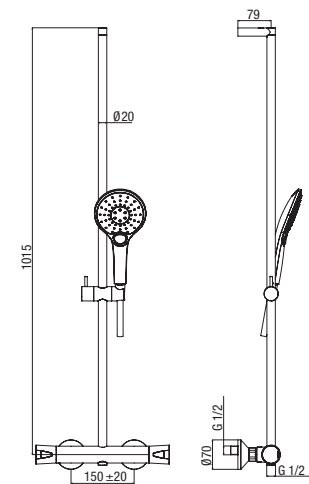

CPL 87101 CR € 338,00

termostatico vasca esterno completo di supporto doccia snodato, flex PVC e doccia **tre getti** anticalcare a pulsante, rosoni con eccentrici rinforzati **"FIX LONG"**
exposed thermostatic bath shower mixer, with adjustable shower bracket, PVC flex hose and three sprays anti-scale handset with press button, flanges and reinforced s-union "FIX LONG"

bain douche thermostatique apparent avec support douchette réglable, flexible PVC et douchette anticalcaire **trois jets**, sélection à bouton, rosaces et raccords excentriques renforcés **"FIX LONG"**

CPL 87106 CR € 290,00

termostatico vasca esterno senza set doccia
exposed thermostatic bath shower mixer without handset kit
 bain douche thermostatique apparent sans kit de douche





Cityplus

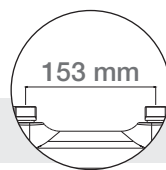

CPL 87106/153 CR € 314,00



termostatico vasca esterno, interasse 153 mm
exposed thermostatic bath shower mixer, inlets distance 153 mm
 bain douche thermostatique apparent, entraxe 153 mm

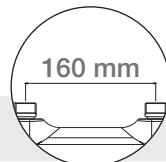

CPL 87106/160 CR € 314,00



termostatico vasca esterno, interasse 160 mm
exposed thermostatic bath shower mixer, inlets distance 160 mm
 bain douche thermostatique apparent, entraxe 160 mm

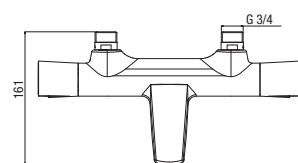
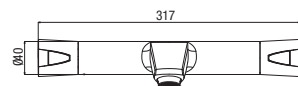

SOLUZIONI INCASSO DOCCIA / VASCA SHOWER / BATH CONCEALED SOLUTIONS SOLUTIONS ENCASTRÉES DOUCHE / BAIN



CPL 87861 CR € 62,00



monocomando doccia incasso
concealed single-lever shower mixer
 douche encastré monocommande

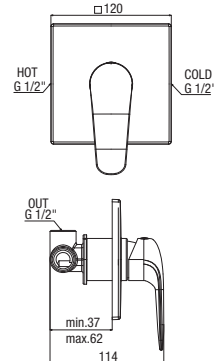

parte incasso compresa
built-in mixer body included
 boîtier d'encastrement fourni



CPL 87863 CR € 123,00



monocomando doccia incasso con deviatore meccanico
concealed single-lever shower mixer with mechanical diverter
 douche encastré monocommande avec inverseur mécanique

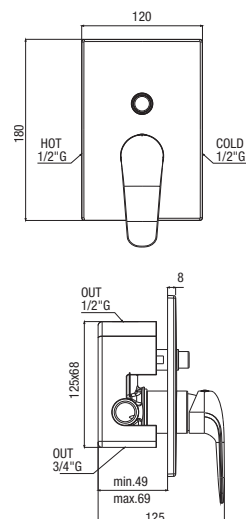

2



parte incasso compresa
built-in mixer body included
boîtier d'encastrement fourni



CPL 87163 CR

€ 429,00

termostatico doccia incasso con deviatore ceramico
due uscite e regolazione portata
concealed thermostatic shower valve
with two outlets ceramic diverter and stop



douche thermostatique encastré avec sélecteur
céramique **deux sorties** et réglage débit

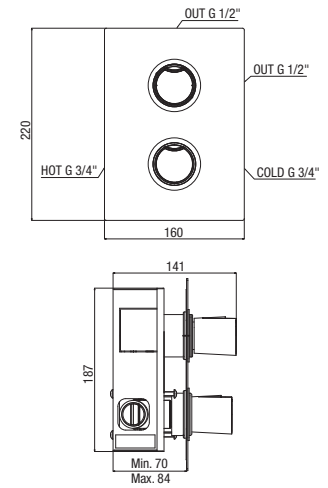

Joy



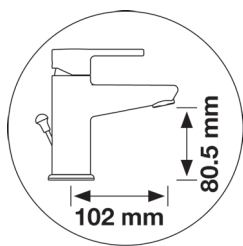

size

R



JO 74276 CR € 92,00

monocomando lavabo, scarico 1 1/4"
single-lever basin mixer, 1 1/4" pop-up waste
 lavabo monocommande, vidage 1 1/4"

JO 74276/S CR € 84,00

monocomando lavabo, senza scarico
single-lever basin mixer, without waste
 lavabo monocommande, sans vidage

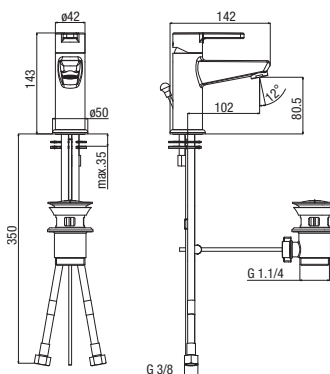

JO 74201 CR € 92,00

monocomando bidet, scarico 1 1/4"
single-lever bidet mixer, 1 1/4" pop-up waste
 bidet monocommande, vidage 1 1/4"

JO 74201/S CR € 84,00

monocomando bidet, senza scarico
single-lever bidet mixer, without waste
 bidet monocommande, sans vidage

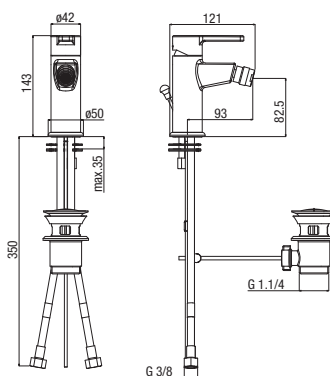

JO 74282 CR € 89,00

monocomando lavello bocca girevole
single-lever sink mixer swivel spout
 évier monocommande bec orientable

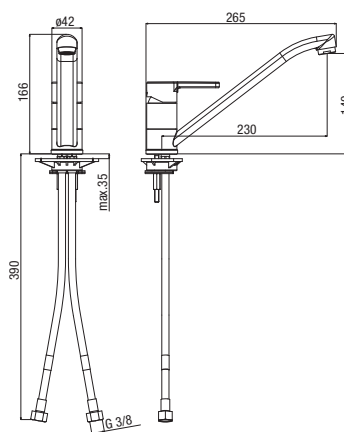



JO 74383 CR

€ 93,00



monocomando lavello bocca girevole
single-lever sink mixer swivel spout
 évier monocommande bec orientable

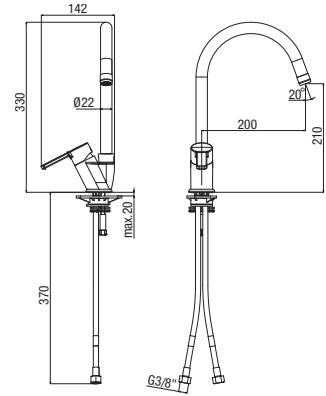

JO 74283 CR

€ 100,00



monocomando lavello bocca girevole
single-lever sink mixer swivel spout
 évier monocommande bec orientable

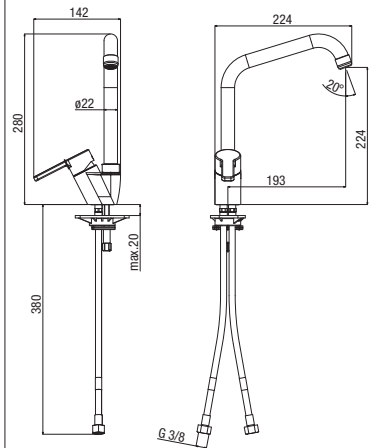

JO 74250 CR

€ 117,00



monocomando lavello a muro
exposed wall-mounted single-lever sink mixer
 évier mural monocommande apparent

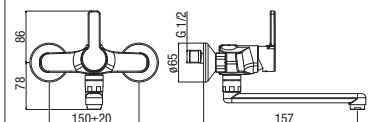



CR 034

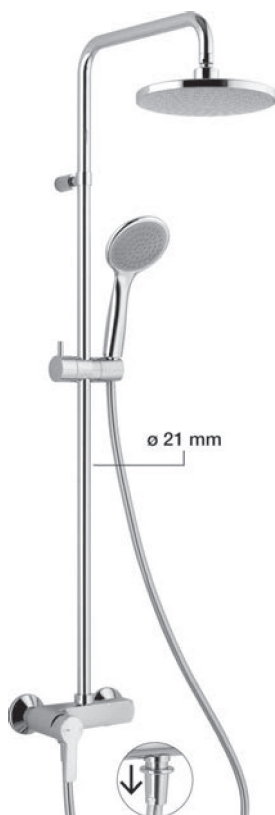

ø 21 mm



Il tubo della colonna doccia può essere tagliato
the riser of the shower column can be cut
 le tube de la colonne de douche peut être coupée



JO 97RP2251 CR

€ 368,00

- colonna doccia monocomando
- deviatore meccanico **EASYpull**
- soffione ø 200 mm
- doccia monogetto anticalcare

single-lever shower column

- *mechanical diverter* **EASYpull**
- *ø 200 mm shower head*
- *one spray anti-scale handset*

colonne de douche monocommande

- inverseur mécanique **EASYpull**
- pomme de douche ø 200 mm
- douchette anticalcaire monojet

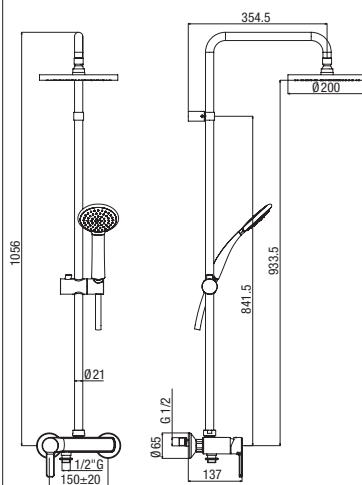

CR 034

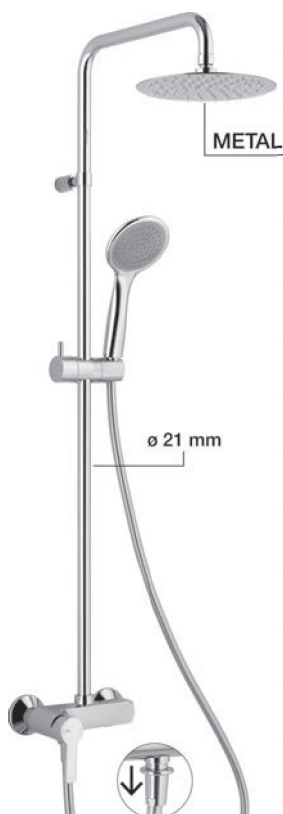

ø 21 mm

METAL



Il tubo della colonna doccia può essere tagliato
the riser of the shower column can be cut
 le tube de la colonne de douche peut être coupée



JO 97RM2251 CR

€ 411,00

- colonna doccia monocomando
- deviatore meccanico **EASYpull**
- soffione ø 200 mm
- doccia monogetto anticalcare

single-lever shower column

- *mechanical diverter* **EASYpull**
- *ø 200 mm shower head*
- *one spray anti-scale handset*

colonne de douche monocommande

- inverseur mécanique **EASYpull**
- pomme de douche ø 200 mm
- douchette anticalcaire monojet

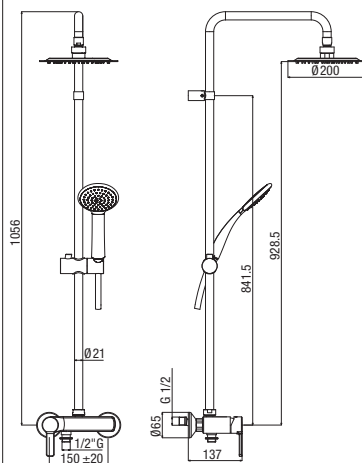

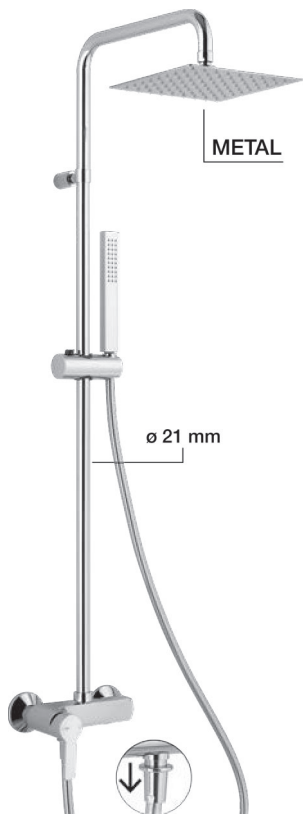

Il tubo della colonna doccia può essere tagliato
 the riser of the shower column can be cut
 le tube de la colonne de douche peut être coupée



EcoStop

JO 97SM2251 CR

€ 440,00

- colonna doccia monocomando
 - deviatore meccanico **EASYpull**
 - soffione 200x200 mm
 - doccia monogetto anticalcare
- single-lever shower column*
 - *mechanical diverter EASYpull*
 - *200x200 mm shower head*
 - *one spray anti-scale handset*
- colonne de douche monocommande
 - inverseur mécanique **EASYpull**
 - pomme de douche 200x200 mm
 - douchette anticalcaire monojet



CR 034

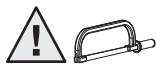
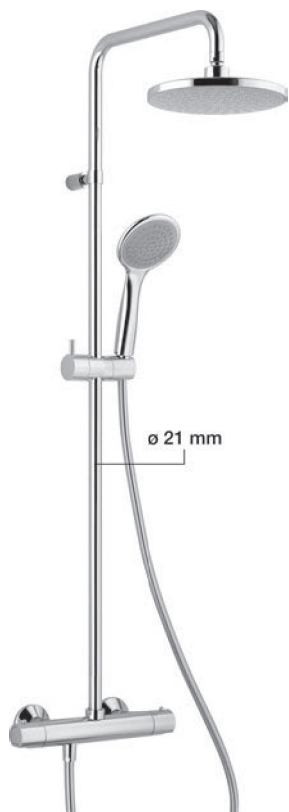
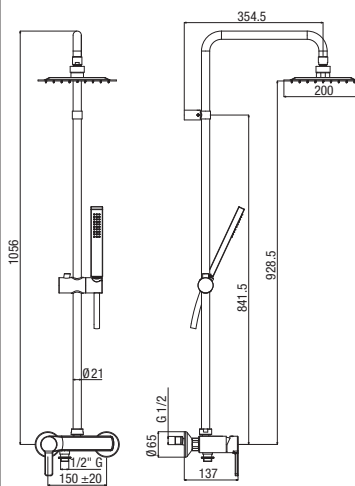

Il tubo della colonna doccia può essere tagliato
 the riser of the shower column can be cut
 le tube de la colonne de douche peut être coupée



JO 97RP2151 CR

€ 405,00

- colonna doccia termostatica
 - deviazione integrata
 - soffione ø 200 mm
 - doccia monogetto anticalcare
- thermostatic shower column*
 - *integrated diverter*
 - *ø 200 mm shower head*
 - *one spray handset anti-scale*
- colonne de douche thermostatique
 - inverseur intégré
 - pomme de douche ø 200 mm
 - douchette monojet anticalcaire



CR 010NC



CR-107C

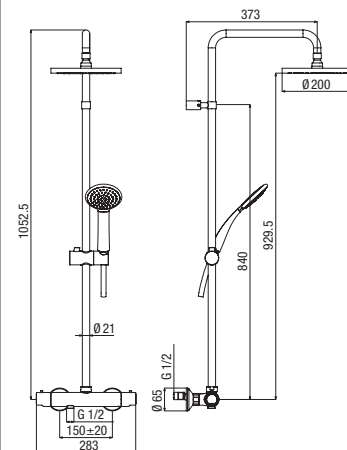

Joy

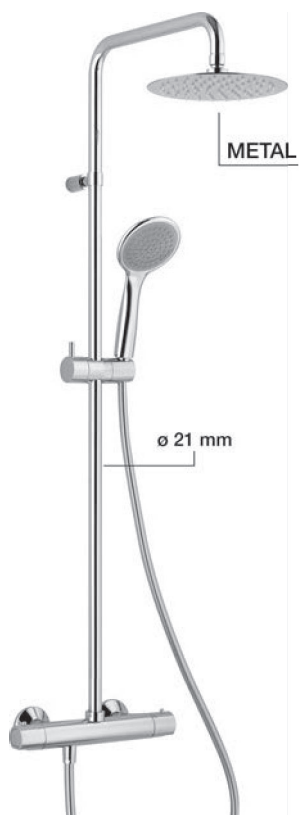

METAL

ø 21 mm



Il tubo della colonna doccia può essere tagliato
the riser of the shower column can be cut
le tube de la colonne de douche peut être coupée



JO 97RM2151 CR

€ 447,00

colonna doccia termostatica
 - deviazione integrata
 - soffione ø 200 mm
 - doccia monogetto anticalcare

thermostatic shower column

- *integrated diverter*
 - *ø 200 mm shower head*
 - *one spray handset anti-scale*

colonne de douche thermostatique
 - inverseur intégré

- *pomme de douche ø 200 mm*
 - *douchette monojet anticalcaire*



CR 010NC



CR-150C

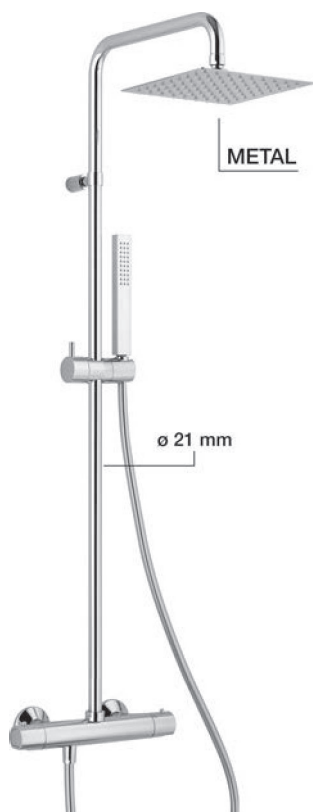
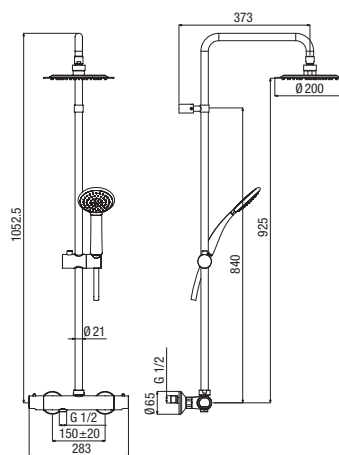

METAL

ø 21 mm

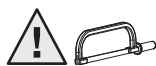

Il tubo della colonna doccia può essere tagliato
the riser of the shower column can be cut
le tube de la colonne de douche peut être coupée



JO 97SM2151 CR

€ 477,00

colonna doccia termostatica
 - deviazione integrata
 - soffione 200x200 mm
 - doccia monogetto anticalcare

thermostatic shower column

- *integrated diverter*
 - *200x200 mm shower head*
 - *one spray handset anti-scale*

colonne de douche thermostatique
 - inverseur intégré

- *pomme de douche 200x200 mm*
 - *douchette monojet anticalcaire*



CR 010NC



CR-150C

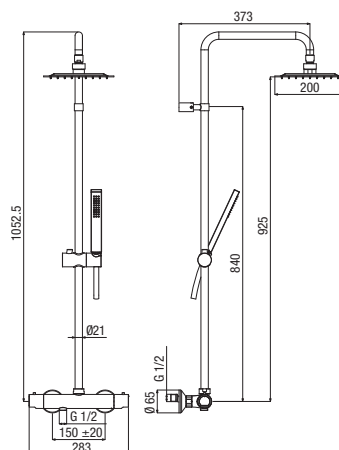



JO 97RM7151 CR € 496,00

- colonna doccia termostatica
- **telescopica**
 - deviazione integrata
 - soffione ø 200 mm
 - doccia monogetto anticalcare
- thermostatic shower column*
- **adjustable**
 - *integrated diverter*
 - *ø 200 mm shower head*
 - *one spray handset anti-scale*
- colonne de douche thermostatique
- **télescopique**
 - inverseur intégré
 - pomme de douche ø 200 mm
 - douchette monojet anticalcaire

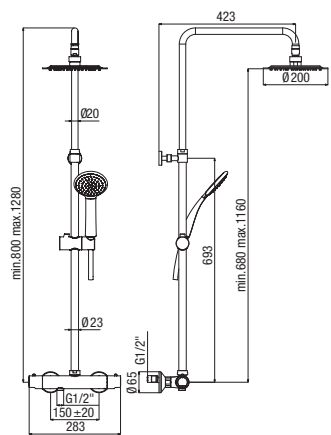

JO 97SM7151 CR € 526,00

- colonna doccia termostatica
- **telescopica**
 - deviazione integrata
 - soffione 200x200 mm
 - doccia monogetto anticalcare
- thermostatic shower column*
- **adjustable**
 - *integrated diverter*
 - *200x200 mm shower head*
 - *one spray handset anti-scale*
- colonne de douche thermostatique
- **télescopique**
 - inverseur intégré
 - pomme de douche 200x200 mm
 - douchette monojet anticalcaire

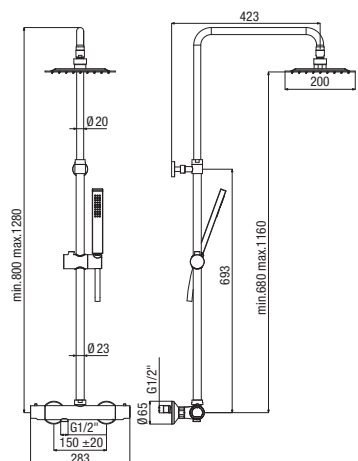

Joy



Ø 105 mm

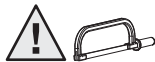

Il tubo della colonna doccia può essere tagliato
the riser of the shower column can be cut
 le tube de la colonne de douche peut être coupée



BC 11151 CR € 276,00



termostatico doccia esterno, kit saliscendi integrato
exposed thermostatic shower mixer, integrated slide rail kit
 douche thermostatique apparent, kit barre de douche intégré

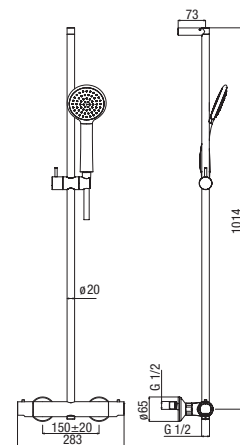

SOLUZIONI ESTERNO DOCCIA / VASCA SHOWER / BATH EXPOSED SOLUTIONS SOLUTIONS APPARENTES DOUCHE / BAIN



JO 74855 CR € 93,00



monocomando doccia esterno
exposed single-lever shower mixer
 douche apparent monocommande

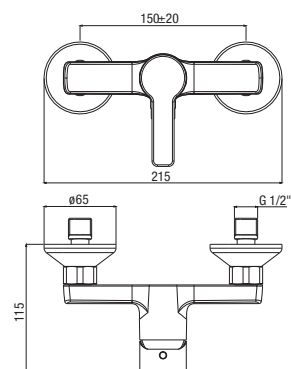

JO 74801 CR € 163,00



monocomando vasca esterno con supporto doccia snodato,
 flessibile doccia PVC e doccia monogetto anticalcare
*exposed single-lever bath shower mixer with adjustable
 shower bracket, shower hose PVC and one spray anti-scale
 handset*

bain douche apparent monocommande avec support
 douchette réglable, flexible de douche PVC et douchette
 monojet anticalcaire

JO 74806 CR € 124,00



monocomando vasca esterno senza set doccia
exposed single-lever bath shower mixer without handset kit
 bain douche apparent monocommande sans kit douchette

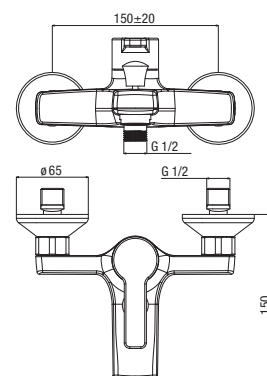



JO 74808 CR

€ 145,00



monocomando bordo vasca
single-lever deck bath shower mixer
 bain douche monocommande monotrou sur gorge

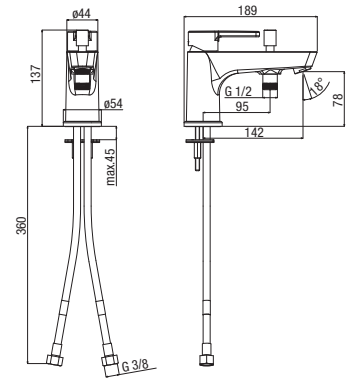

JO 74155 CR

€ 138,00



termostatico doccia esterno
exposed thermostatic shower mixer
 douche thermostatique apparent

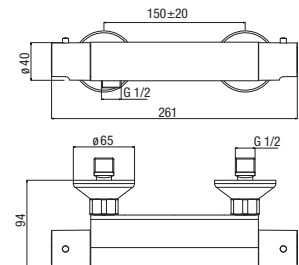

JO 74155/60 CR

€ 163,00



termostatico doccia esterno, interasse 60/140 mm
exposed thermostatic shower mixer, inlets distance 60/140 mm
 douche thermostatique apparent, entraxe 60/140 mm

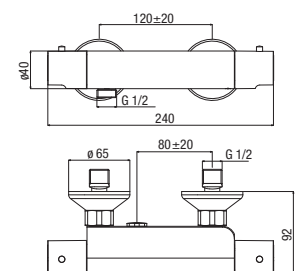
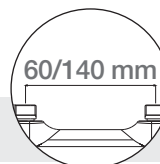

JO 74155/120 CR

€ 138,00



termostatico doccia esterno, interasse 100/140 mm
exposed thermostatic shower mixer, inlets distance 100/140 mm
 douche thermostatique apparent, entraxe 100/140 mm





JO 74106 CR

€ 194,00

termostatico vasca esterno
exposed thermostatic bath shower mixer
 bain douche thermostatique apparent



VT 002



CR-150C

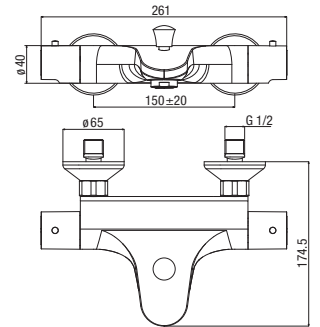

JO 74108 CR

€ 214,00

termostatico bordo vasca
thermostatic deck bath shower mixer
 bain douche thermostatique monotrou sur gorge



VT 002



CR-101C

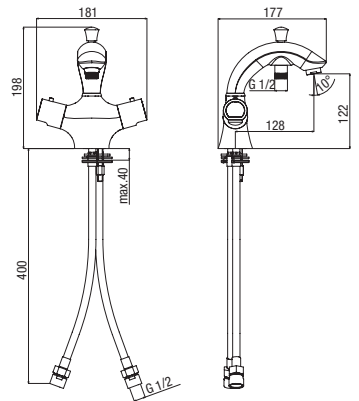

SOLUZIONI INCASSO DOCCIA / VASCA SHOWER / BATH CONCEALED SOLUTIONS SOLUTIONS ENCASTRÉES DOUCHE / BAIN

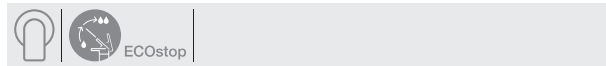

JO 74861 CR € 60,00



monocomando doccia incasso
concealed single-lever shower mixer
 douche encastré monocommande



CR 035

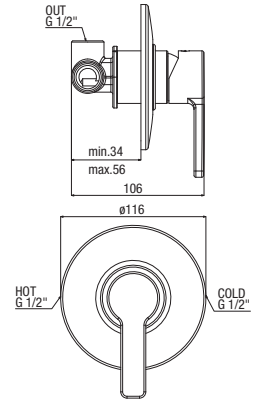

CR 035



parte incasso compresa
built-in mixer body included
 boîtier d'encastrement fourni

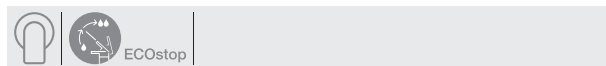

JO 74863 CR € 122,00



monocomando doccia incasso con deviatore meccanico
concealed single-lever shower mixer with mechanical diverter
 douche encastré monocommande avec inverseur mécanique

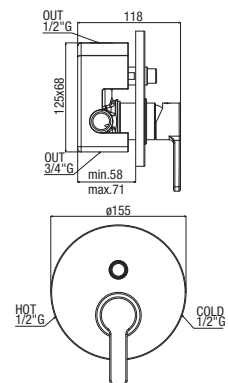

CR-110C

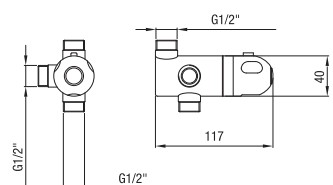

TA 54145 CR € 77,00



termostatico sottoboiler esterno
exposed under boiler thermostatic valve
 régulateur thermostatique apparent pour chauffe-eau

Sport Senior



Sport senior

LAVABO E BIDET *BASIN AND BIDET* LAVABO ET BIDET

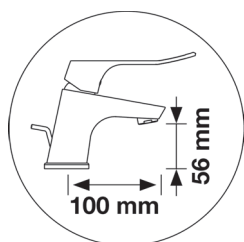

size

R



flessibili INOX antitorsione
connection hoses anti-twist
flexibles de raccordement antitorsion



SPS 86176 CR

€ 117,00

monocomando lavabo, scarico 1 1/4"
single-lever basin mixer, 1 1/4" pop-up waste
lavabo monocommande, vidage 1 1/4"

SPS 86176/S CR

€ 109,00

monocomando lavabo, senza scarico
single-lever basin mixer, without waste
lavabo monocommande, sans vidage



CR 005

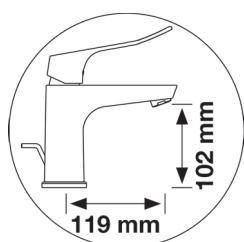
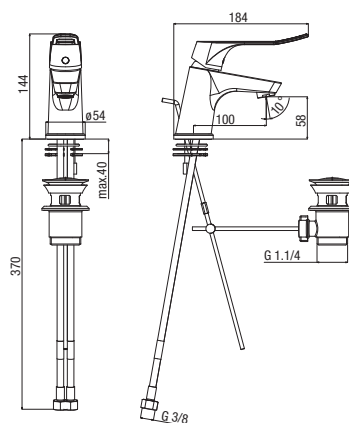

size

M



flessibili INOX antitorsione
connection hoses anti-twist
flexibles de raccordement antitorsion



SPS 86179 CR

€ 143,00

monocomando lavabo medio, scarico 1 1/4"
single-lever medium basin mixer, 1 1/4" pop-up waste
lavabo monocommande moyen, vidage 1 1/4"

SPS 86179/S CR

€ 135,00

monocomando lavabo medio, senza scarico
single-lever medium basin mixer, without waste
lavabo monocommande moyen, sans vidage



CR 005

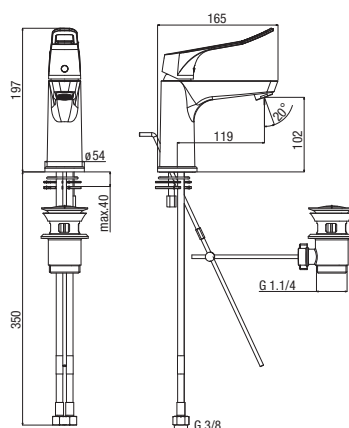

flessibili INOX antitorsione
connection hoses anti-twist
flexibles de raccordement antitorsion



SPS 86221 CR

€ 117,00

monocomando bidet, scarico 1 1/4"
single-lever bidet mixer, 1 1/4" pop-up waste
bidet monocommande, vidage 1 1/4"

SPS 86221/S CR

€ 109,00

monocomando bidet, senza scarico
single-lever bidet mixer, without waste
bidet monocommande, sans vidage



CR 005

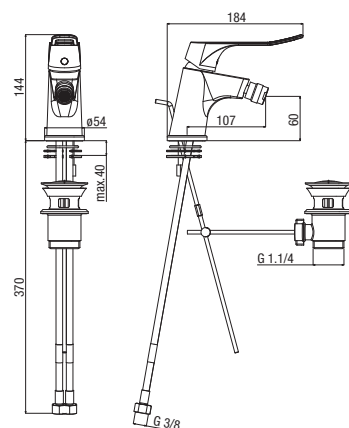

size
M



CL 59176 CR € 302,00

termostatico lavabo medio, scarico 1 1/4"
medium thermostatic basin mixer, 1 1/4" pop-up waste
 lavabo thermostatique moyen, vidage 1 1/4"

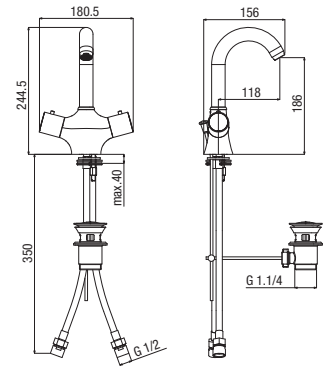

CL 59201 CR € 302,00

termostatico bidet, scarico 1 1/4"
thermostatic bidet mixer, 1 1/4" pop-up waste
 bidet thermostatique, vidage 1 1/4"

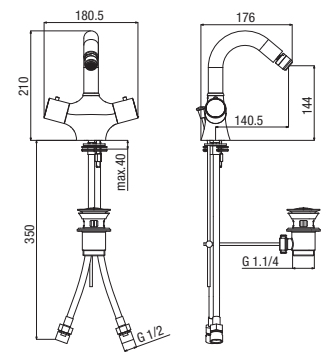
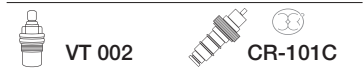

CUCINA SINK EVIER



SPS 86282 CR € 137,00

monocomando lavello
single-lever sink mixer
 évier monocommande

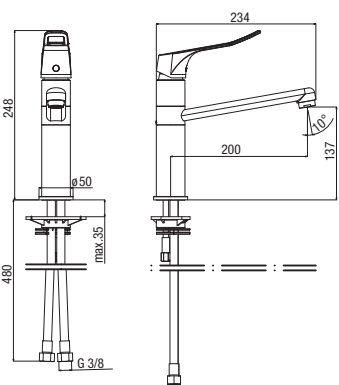

SPS 86250 CR € 143,00

monocomando lavello a muro
exposed wall-mounted single-lever sink mixer
 évier mural monocommande apparent

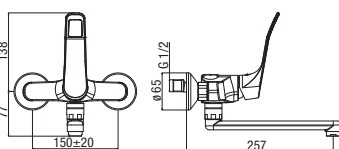

Sport senior

COLONNE DOCCIA SHOWER COLUMN COLONNES DE DOUCHE



SPS 86RM2151 CR

€ 647,00

colonna doccia termostatica
- deviazione integrata
- soffione ø 200 mm
- doccia monogetto anticalcare
con sistema **AIRmix**

thermostatic shower column
- *integrated diverter*
- *ø 200 mm shower head*
- *one spray handset anti-scale*
with **AIRmix** saving system

colonne de douche thermostatique
- inverseur intégré
- pomme de douche ø 200 mm
- douchette monojet anticalcaire
avec système **AIRmix**

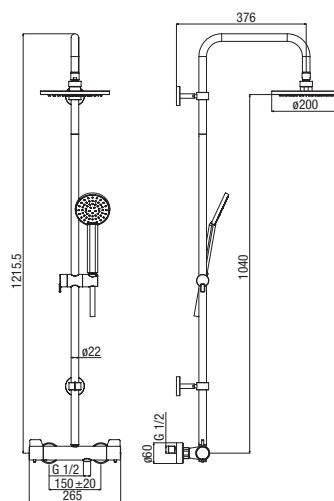

SOLUZIONI ESTERNO DOCCIA / VASCA SHOWER / BATH EXPOSED SOLUTIONS SOLUTIONS APPARENTES DOUCHE / BAIN



SPS 86855 CR

€ 123,00

monocomando doccia esterno
exposed single-lever shower mixer
douche apparente monocommande

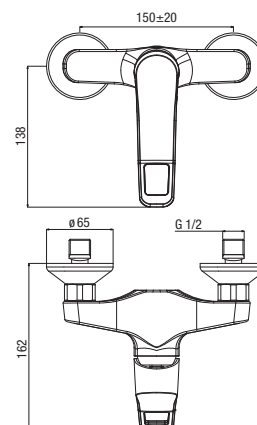



SPS 86801 CR € 208,00

monocomando vasca esterno con supporto doccia, flessibile doccia PVC e doccia monogetto anticalcare con sistema **AIRmix**

exposed single-lever bath shower mixer with shower bracket, shower hose PVC and one spray handset anti-scale with AIRmix saving system

bain douche apparent monocommande avec support douchette, flexible de douche PVC et douchette monojet anticalcaire avec système **AIRmix**



SPS 86806 CR € 160,00

monocomando vasca esterno senza set doccia

exposed single-lever bath shower mixer without handset kit

bain douche apparent monocommande sans kit douchette

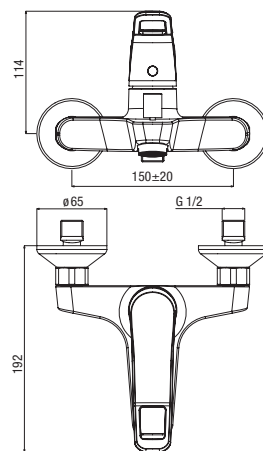

SPS 86155 CR € 178,00

termostatico doccia esterno

exposed thermostatic shower mixer

douche thermostatique apparent

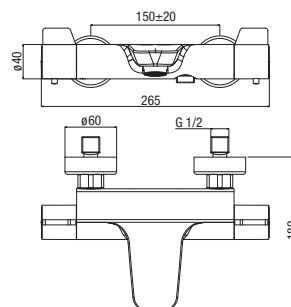
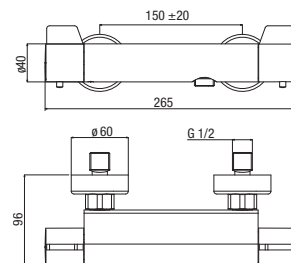

SPS 86106 CR € 254,00

termostatico vasca esterno

exposed thermostatic bath shower mixer

bain douche thermostatique apparent



Sport senior

SOLUZIONI INCASSO DOCCIA / VASCA SHOWER / BATH CONCEALED SOLUTIONS SOLUTIONS ENCASTRÉES DOUCHE / BAIN



SPS 86861 CR

€ 85,00



monocomando doccia incasso
concealed single-lever shower mixer
douche encastré monocommande



CR 023

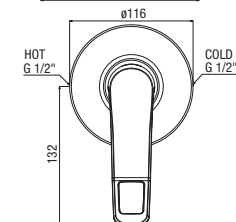
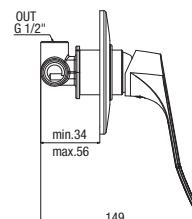

parte incasso compresa
built-in mixer body included
boîtier d'encastrement fourni



SPS 86863 CR

€ 146,00



monocomando doccia incasso con deviatore meccanico
concealed single-lever shower mixer with mechanical diverter
douche encastré monocommande avec inverseur mécanique



CR 023

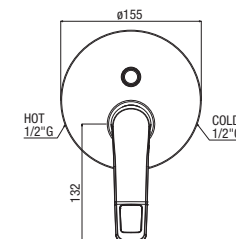
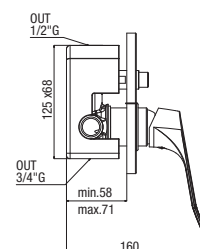

parte incasso compresa
built-in mixer body included
boîtier d'encastrement fourni



SPS 86161 CR

€ 347,00



termostatico doccia incasso con rubinetto regolazione portata
concealed thermostatic shower valve with stop cock
douche thermostatique encastré avec robinet d'arrêt



VT 002



CR-107C

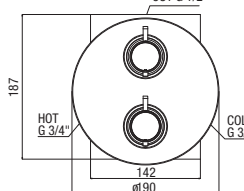
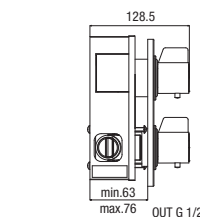



parte incasso compresa
built-in mixer body included
 boîtier d'encastrement fourni



SPS 86163 CR

€ 442,00

termostatico doccia incasso con deviatore ceramico
due uscite e regolazione portata
concealed thermostatic shower valve with
two outlets ceramic diverter and stop



douche thermostatique encastré avec sélecteur céramique
deux sorties et réglage débit

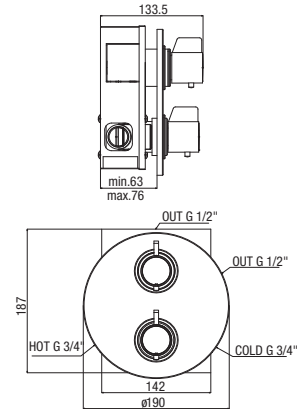

ACCESSORI ACCESSORIES ACCESSOIRES



DC 059 CR

€ 39,00

doccia ergonomica anticalcare **tre getti**
three sprays antiscald ergonomic handset
 douchette ergonomique anticalcaire **trois jets**

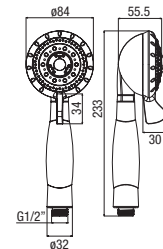

Clinic MR

clinic reduced mobility
clinic mobilité réduite



Clinic MR

clinic reduced mobility
clinic mobilité réduite



Una percentuale importante della popolazione è costituita da persone con deficit motori o sensoriali e le strutture quali **ospedali, cliniche, case di cura o le stesse abitazioni private**... non sempre sono idoneamente attrezzate nell'ambiente bagno per consentire loro una gestione autonoma e sicura della propria intimità. Alle persone che si trovano in una condizione di **permanente disabilità**, occorre aggiungere coloro che si trovano in una condizione "naturale" di **diversa abilità**, quali **bambini, anziani, portatori di traumi non permanenti**.

*A significant percentage of the population consists of people with sensory or motor deficits and facilities such as **hospitals, clinics and nursing homes and even in the domestic bathrooms etc.** are not always properly equipped in the bathroom environment to allow people with disabilities to use these facilities autonomously, safely and in private. In addition to people with a **permanent disability**, it is also necessary to add people who are "naturally" **less able**, such as **children, the elderly, people with non-permanent injuries**.*

lavabo altezza maggiorata
higher spout
single lever mixer
lavabo monocommande avec hauteur augmentée



Un pourcentage important de la population est constitué de personnes présentant des déficits moteurs et sensoriels, or les structures telles que **les hôpitaux, les cliniques, les établissements de soins et même les salles de bains des habitations**... ne sont pas toujours équipées de manière appropriée dans la salle de bain pour permettre aux personnes en condition de handicap une gestion autonome et sûre de leur intimité. Il faut ajouter aux personnes présentant une **condition de handicap permanent**, celles qui se trouvent dans une condition "naturelle" de **difficulté**, telles que **les enfants, les personnes âgées, les porteurs de traumatismes non permanents**.



serigrafie evidenti
very clear screen printing
sérigraphies très claires



blocco a 38°
stop at 38°
blocage à 38°



temperatura costante
constant temperature
température constante

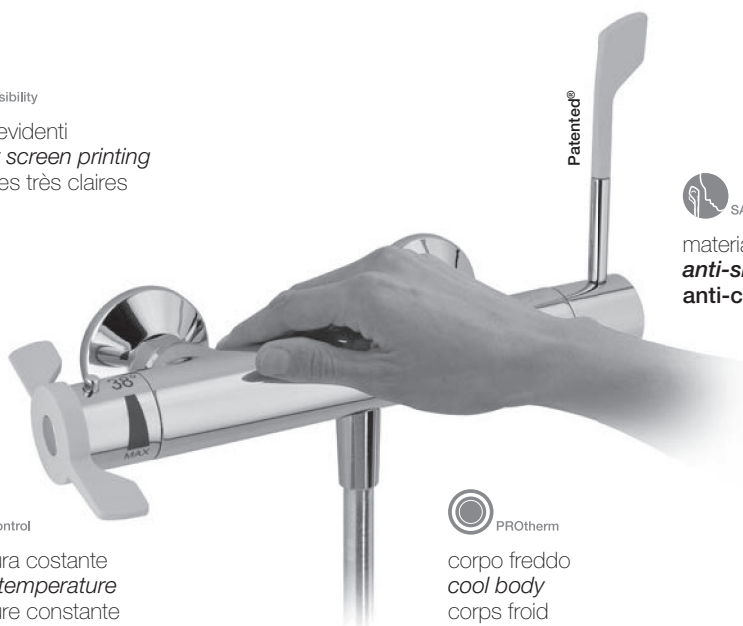

materiale **antishock** senza spigoli
anti-shock material without corners
anti-choc doux sans arêtes vives



corpo freddo
cool body
corps froid

Clinic MR



MR 90178 CR

€ 289,00

monocomando lavabo h 110 mm, leva lunga mobilità ridotta, bocca girevole, doccia laterale multiuso

single-lever basin mixer h 110 mm, easy-to-use long lever, swivel spout, multipurpose side handset

lavabo monocommande h 110 mm, manette longue mobilité réduite, bec orientable, douche latérale multi-fonction

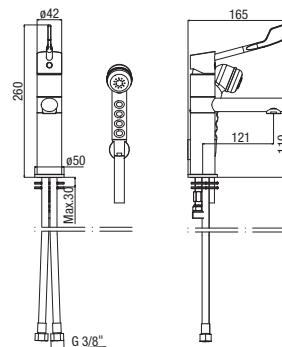

MR 90276 CR

€ 283,00

termostatico lavabo, leva corta mobilità ridotta, scarico 1 1/4" *thermostatic basin mixer, easy-to-use short lever, 1 1/4" pop up waste*

lavabo thermostatique levier court mobilité réduite, vidage 1 1/4"

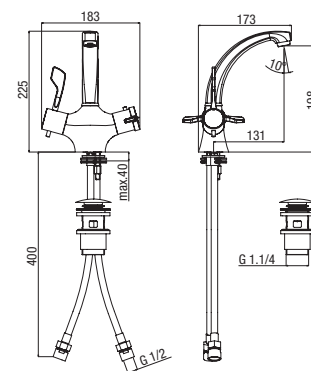

CUCINA SINK EVIER



MR 90850 CR

€ 138,00

monocomando lavello a muro, leva lunga mobilità ridotta *exposed wall-mounted single-lever sink mixer, easy-to-use long lever*

évier mural monocommande apparent, manette longue mobilité réduite

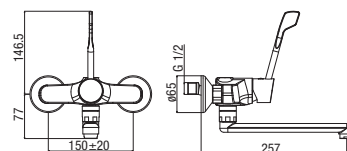

Clinic MR

COLONNE DOCCIA SHOWER COLUMN COLONNES DE DOUCHE



MR 90RP2151 CR

€ 691,00

- colonna doccia termostatica
- leva lunga mobilità ridotta
- soffione ø 200 mm
- doccia ergonomica anticalcare **tre getti**
- thermostatic shower column*
- *easy-to-use long lever*
- *ø 200 mm shower head*
- **three sprays antiscalare ergonomic handset**
- colonne de douche thermostatique
- levier long mobilité réduite
- pomme de douche ø 200 mm
- **douchette ergonomique anticalcaire trois jets**

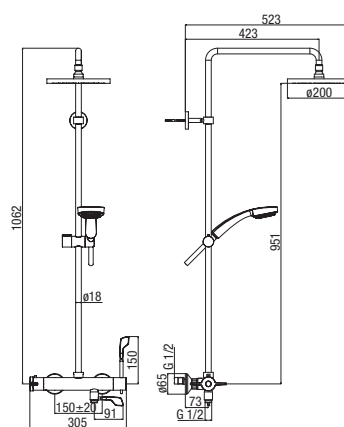

SOLUZIONI ESTERNO DOCCIA / VASCA SHOWER / BATH EXPOSED SOLUTIONS SOLUTIONS APPARENTES DOUCHE / BAIN



MR 90155 CR € 194,00

termostatico doccia esterno, leva lunga mobilità ridotta
exposed thermostatic shower mixer, easy-to-use long lever
 douche thermostatique apparent, levier long mobilité réduite

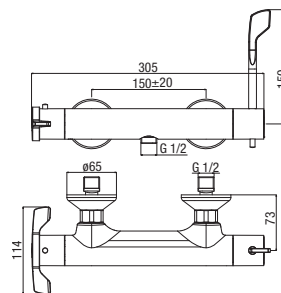

MR 90106 CR € 314,00

termostatico vasca esterno, leva lunga mobilità ridotta
exposed thermostatic bath shower mixer, easy-to-use long lever
 bain douche thermostatique apparent, levier long mobilité réduite

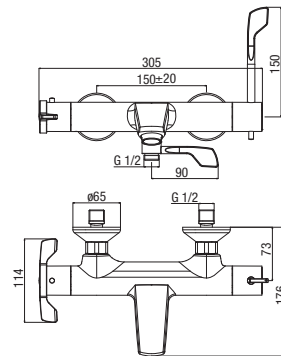

SOLUZIONI INCASSO DOCCIA / VASCA SHOWER / BATH CONCEALED SOLUTIONS SOLUTIONS ENCASTRÉES DOUCHE / BAIN



parte incasso compresa
built-in mixer body included
 boîtier d'encastrement fourni



MR 90161 CR € 358,00

termostatico doccia incasso con rubinetto regolazione portata,
 leva corta mobilità ridotta
concealed thermostatic shower valve with stop cock, easy-to-use short lever
 douche thermostatique encastré avec robinet d'arrêt,
 levier court mobilité réduite

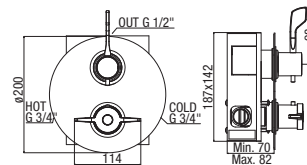

ACCESSORI ACCESSORIES ACCESSOIRES



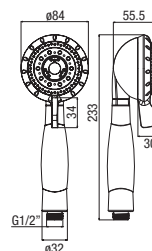

DC 059 CR € 39,00

doccia ergonomica anticalcare **tre getti**
three sprays antiscald ergonomic handset
 douchette ergonomique anticalcaire **trois jets**



Colonne doccia

shower columns
colonnes de douche

Colonne doccia monocomando <i>single-lever shower columns</i> colonnes de douche monocommande		78
Colonne doccia termostatiche <i>thermostatic shower columns</i> colonnes de douche thermostatique		82

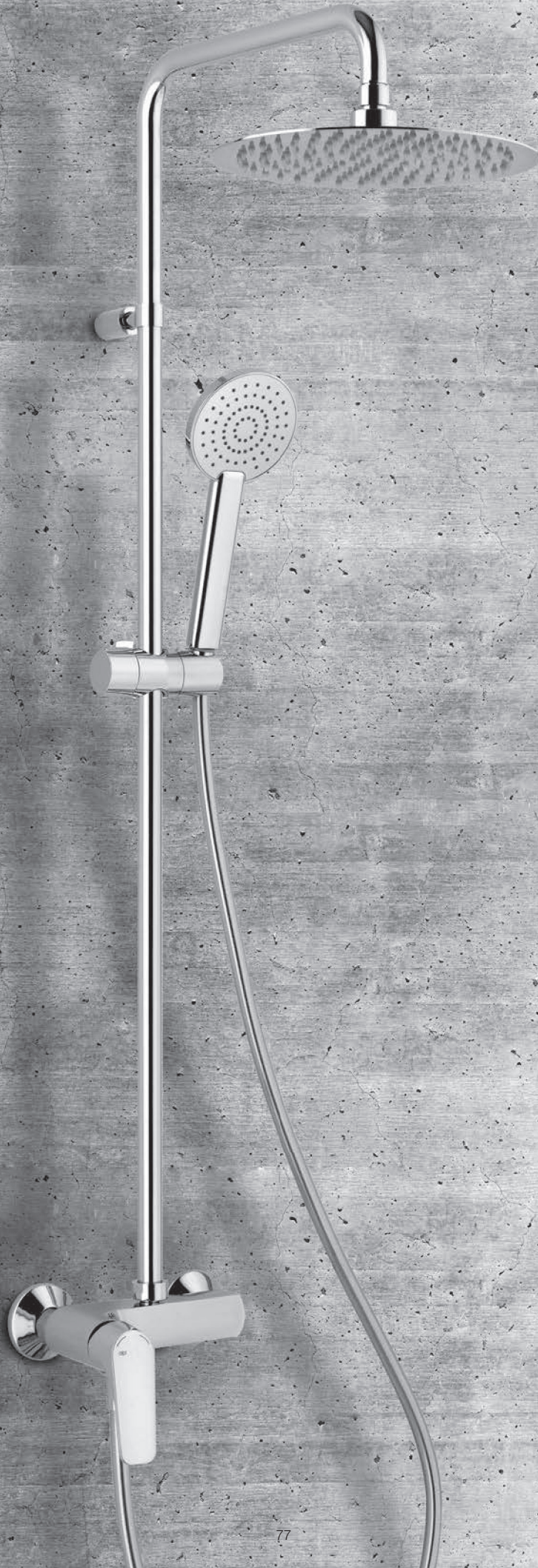

Colonne doccia

COLONNE DOCCIA MONOCOMANDO SINGLE LEVER SHOWER COLUMNS COLONNES DE DOUCHE MONOCOMMANDE

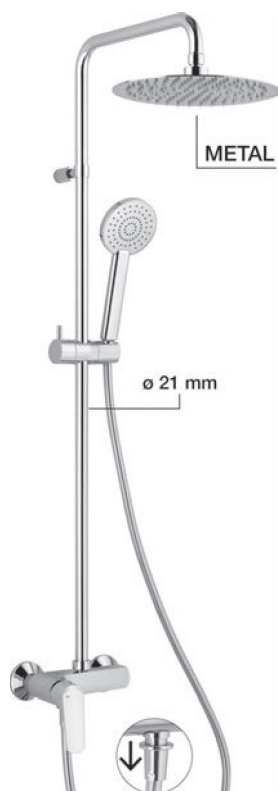

Il tubo della colonna doccia può essere tagliato
the riser of the shower column can be cut
 le tube de la colonne de douche peut être coupée



SPL 96RM2251 CR

€ 472,00

colonna doccia monocomando
 - deviatore meccanico **EASYpull**
 - soffione ø 250 mm
 - doccia monogetto anticalcare
 con sistema **AIRmix**

single-lever shower column
 - *mechanical diverter EASYpull*
 - *ø 250 mm shower head*
 - *one spray handset anti-scale*
 with **AIRmix** saving system

colonne de douche monocommande
 - inverseur mécanique **EASYpull**
 - pomme de douche ø 250 mm
 - douchette monojet anticalcaire
 avec système **AIRmix**

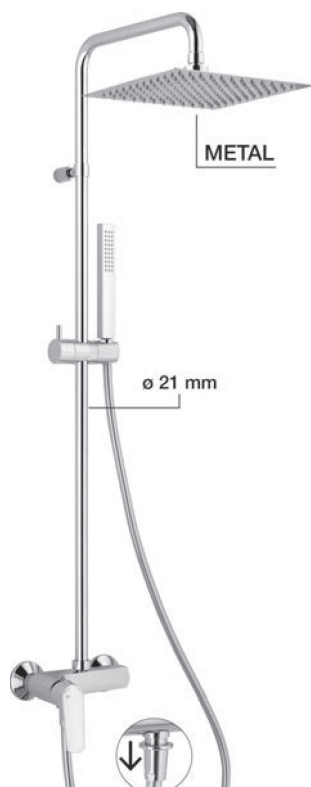
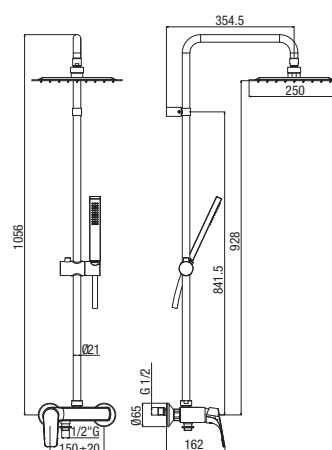
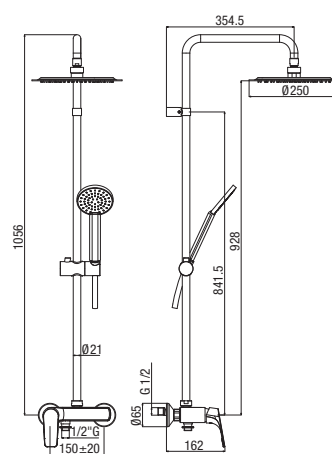

Il tubo della colonna doccia può essere tagliato
the riser of the shower column can be cut
 le tube de la colonne de douche peut être coupée



SPL 96SM2251 CR

€ 501,00

colonna doccia monocomando
 - deviatore meccanico **EASYpull**
 - soffione 250x250 mm
 - doccia monogetto anticalcare

single-lever shower column
 - *mechanical diverter EASYpull*
 - *250x250 mm shower head*
 - *one spray handset anti-scale*

colonne de douche monocommande
 - inverseur mécanique **EASYpull**
 - pomme de douche 250x250 mm
 - douchette monojet anticalcaire



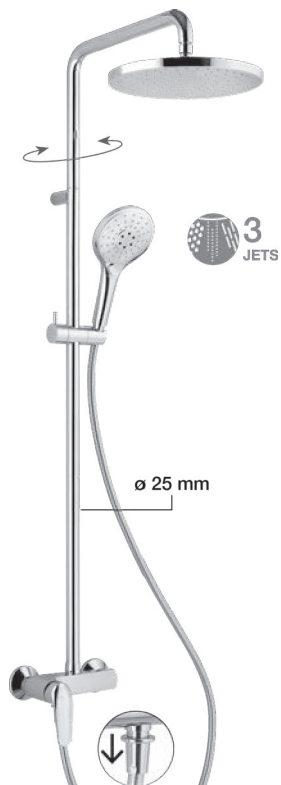

Il tubo della colonna doccia può essere tagliato
the riser of the shower column can be cut
 le tube de la colonne de douche peut être coupée



CPL 87RP2251 CR € 459,00

- colonna doccia monocomando
- tubo doccia tagliabile e orientabile
 - deviatore meccanico **EASYpull**
 - soffione ø 250 mm
 - doccia **tre getti** anticalcare a pulsante
 - flessibile doccia PVC
 - rosconi con eccentrici rinforzati "**FIX LONG**"

single-lever shower column

- *cuttable and swivelling shower pipe*
- *mechanical diverter **EASYpull***
- *ø 250 mm shower head*
- ***three sprays** anti-scale handset with press button*
- *shower hose PVC*
- *flanges and reinforced s-union "**FIX LONG**"*

colonne de douche monocommande

- tube de la colonne cuttable et pivotant
- inverseur mécanique **EASYpull**
- pomme de douche ø 250 mm
- douchette anticalcaire **trois jets**, sélection à bouton
- flexible de douche PVC
- rosaces et raccords excentriques renforcés "**FIX LONG**"



CR 005

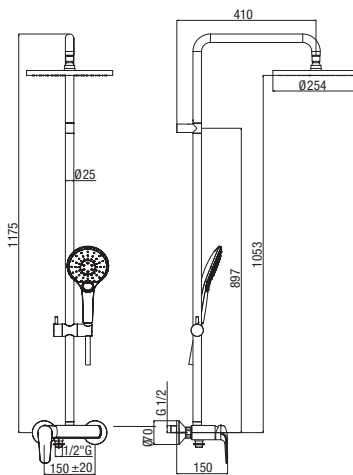

Il tubo della colonna doccia può essere tagliato
the riser of the shower column can be cut
 le tube de la colonne de douche peut être coupée



CPL 87SP2251 CR € 489,00

- colonna doccia monocomando
- tubo doccia tagliabile e orientabile
 - deviatore meccanico **EASYpull**
 - soffione 250x250 mm
 - doccia **tre getti** anticalcare a pulsante
 - flessibile doccia PVC
 - rosconi con eccentrici rinforzati "**FIX LONG**"

single-lever shower column

- *cuttable and swivelling shower pipe*
- *mechanical diverter **EASYpull***
- *250x250 mm shower head*
- ***three sprays** anti-scale handset with press button*
- *shower hose PVC*
- *flanges and reinforced s-union "**FIX LONG**"*

colonne de douche monocommande

- tube de la colonne cuttable et pivotant
- inverseur mécanique **EASYpull**
- pomme de douche 250x250 mm
- douchette anticalcaire **trois jets**, sélection à bouton
- flexible de douche PVC
- rosaces et raccords excentriques renforcés "**FIX LONG**"



CR 005

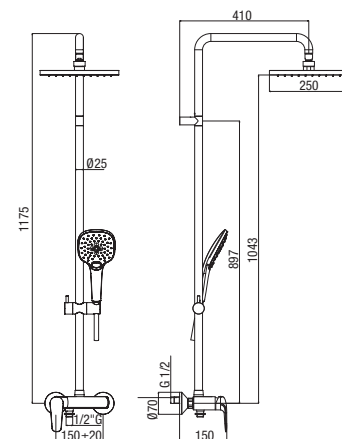

Colonne doccia

 CR 034

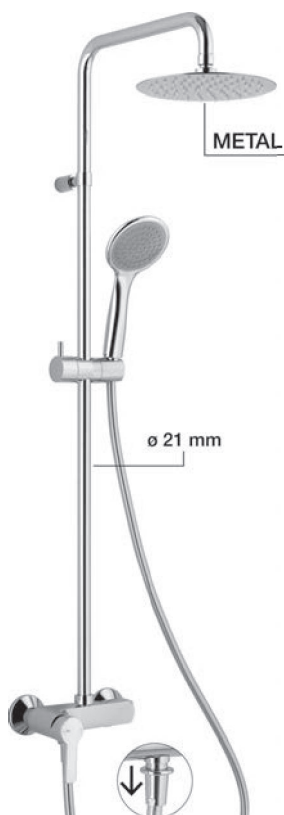

Il tubo della colonna doccia può essere tagliato
the riser of the shower column can be cut
 le tube de la colonne de douche peut être coupée



JO 97RM2251 CR

€ 411,00

colonna doccia monocomando
 - deviatore meccanico **EASYpull**
 - soffione ø 200 mm
 - doccia monogetto anticalcare

single-lever shower column
 - *mechanical diverter EASYpull*
 - *ø 200 mm shower head*
 - *one spray anti-scale handset*

colonne de douche monocomande
 - inverseur mécanique **EASYpull**
 - pomme de douche ø 200 mm
 - douchette anticalcaire monojet

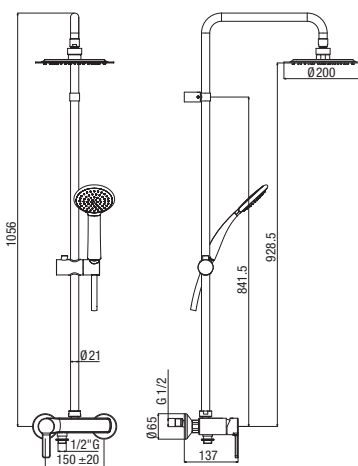

 CR 034

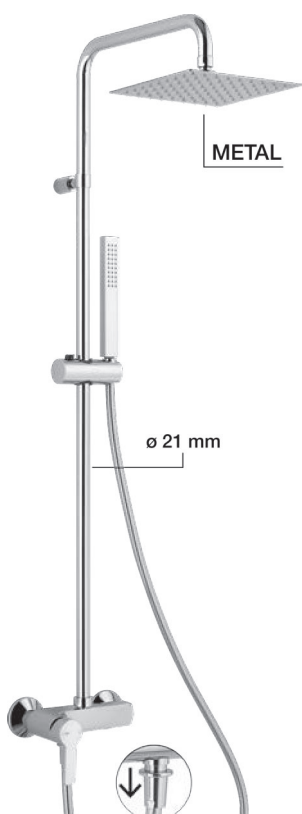

Il tubo della colonna doccia può essere tagliato
the riser of the shower column can be cut
 le tube de la colonne de douche peut être coupée



JO 97SM2251 CR

€ 440,00

colonna doccia monocomando
 - deviatore meccanico **EASYpull**
 - soffione 200x200 mm
 - doccia monogetto anticalcare

single-lever shower column
 - *mechanical diverter EASYpull*
 - *200x200 mm shower head*
 - *one spray anti-scale handset*

colonne de douche monocomande
 - inverseur mécanique **EASYpull**
 - pomme de douche 200x200 mm
 - douchette anticalcaire monojet

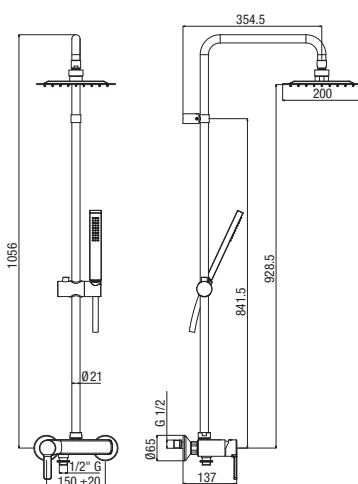

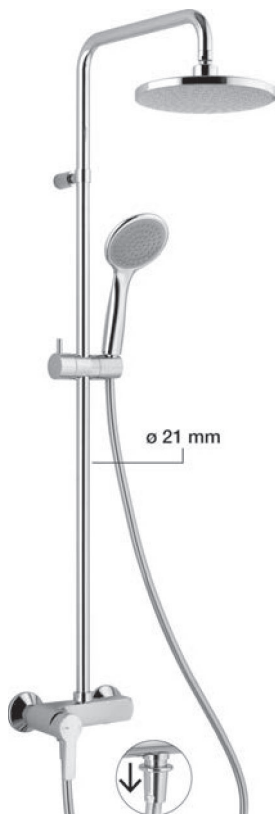

Il tubo della colonna doccia può essere tagliato
the riser of the shower column can be cut
 le tube de la colonne de douche peut être coupée



ECOstop

JO 97RP2251 CR

€ 368,00

- colonna doccia monocomando
- deviatore meccanico **EASYpull**
 - soffione \varnothing 200 mm
 - doccia monogetto anticalcare
- single-lever shower column*
- *mechanical diverter EASYpull*
 - *\varnothing 200 mm shower head*
 - *one spray anti-scale handset*

- colonne de douche monocommande
- inverseur mécanique **EASYpull**
 - pomme de douche \varnothing 200 mm
 - douchette anticalcaire monojet



CR 034

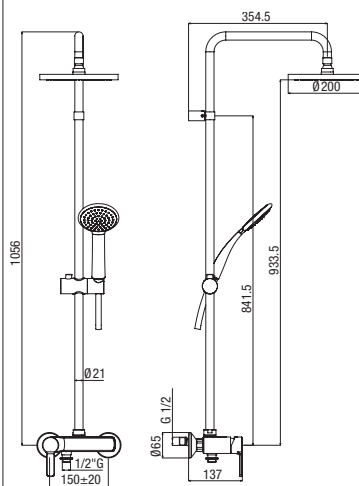

COLONNE DOCCIA TELESCOPICHE ADJUSTABLE SHOWER COLUMN COLONNES DE DOUCHE TELESCOPIQUE



ECOstop

SPL 96RP7251 CR

€ 513,00

- colonna doccia monocomando
- **telescopica**
 - deviatore meccanico **EASYpull**
 - soffione \varnothing 200 mm
 - doccia monogetto anticalcare con sistema **AIRmix**
- single-lever shower column*
- **adjustable**
 - *mechanical diverter EASYpull*
 - *\varnothing 200 mm shower head*
 - *one spray handset anti-scale with AIRmix saving system*

- colonne de douche monocommande
- **télescopique**
 - inverseur mécanique **EASYpull**
 - pomme de douche \varnothing 200 mm
 - douchette monojet anticalcaire avec système **AIRmix**



CR 034

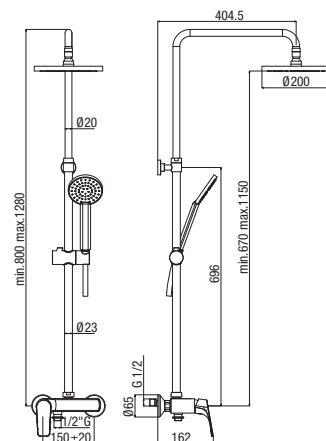

Colonne doccia

COLONNE DOCCIA TERMOSTATICHE THERMOSTATIC SHOWER COLUMN COLONNES DE DOUCHE THERMOSTATIQUE

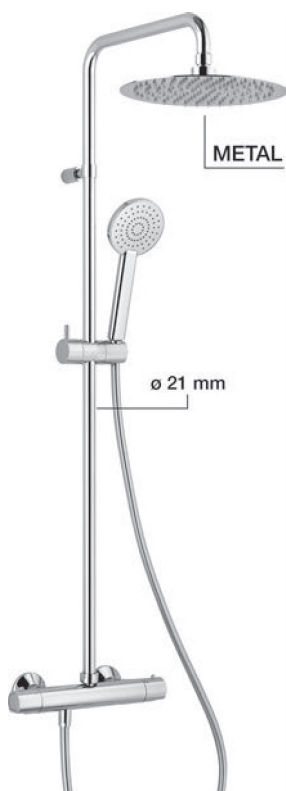

Il tubo della colonna doccia può essere tagliato
the riser of the shower column can be cut
 le tube de la colonne de douche peut être coupée



SPL 96RM2151 CR € 555,00

colonna doccia termostatica
 - deviazione integrata
 - soffione ø 250 mm
 - doccia monogetto anticalcare
 con sistema **AIRmix**

thermostatic shower column
 - *integrated diverter*
 - *ø 250 mm shower head*
 - *one spray handset anti-scale*
 with **AIRmix** saving system

colonne de douche thermostatique
 - inverseur intégré
 - pomme de douche ø 250 mm
 - douchette monojet anticalcaire
 avec système **AIRmix**

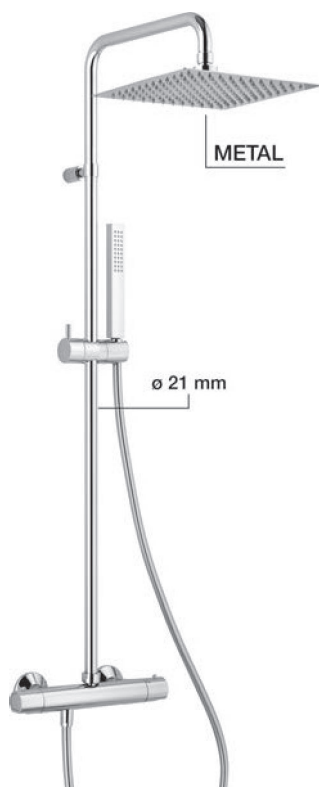
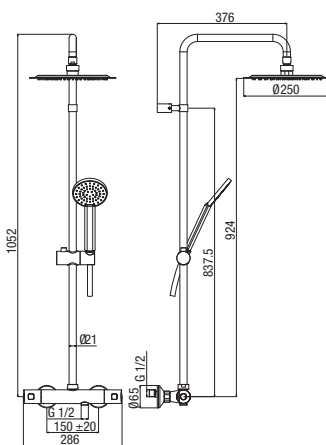

Il tubo della colonna doccia può essere tagliato
the riser of the shower column can be cut
 le tube de la colonne de douche peut être coupée



SPL 96SM2151 CR € 585,00

colonna doccia termostatica
 - deviatore meccanico
 - soffione 250x250 mm
 - doccia monogetto anticalcare

thermostatic shower column
 - *mechanical diverter*
 - *250x250 mm shower head*
 - *one spray handset anti-scale*

colonne de douche thermostatique
 - inverseur mécanique
 - pomme de douche 250x250 mm
 - douchette monojet anticalcaire

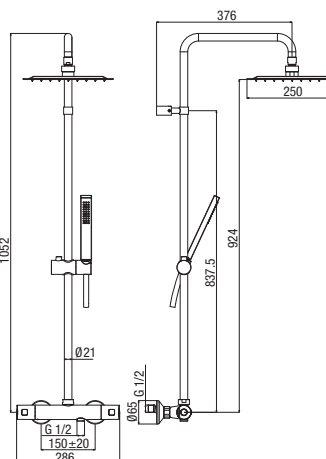

Colonne doccia

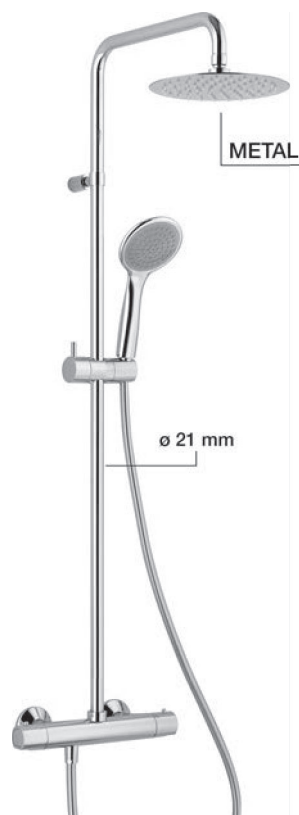

METAL

ø 21 mm



Il tubo della colonna doccia può essere tagliato
the riser of the shower column can be cut
 le tube de la colonne de douche peut être coupée



JO 97RM2151 CR

€ 447,00

colonna doccia termostatica
 - deviazione integrata
 - soffione ø 200 mm
 - doccia monogetto anticalcare
thermostatic shower column
 - integrated diverter
 - ø 200 mm shower head
 - one spray handset anti-scale
 colonne de douche thermostatique
 - inverseur intégré
 - pomme de douche ø 200 mm
 - douchette monojet anticalcaire

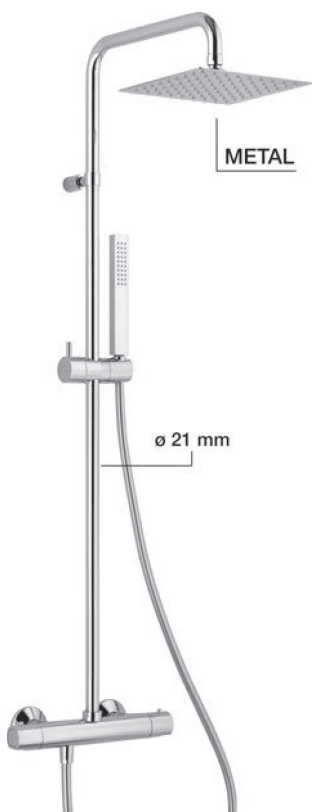
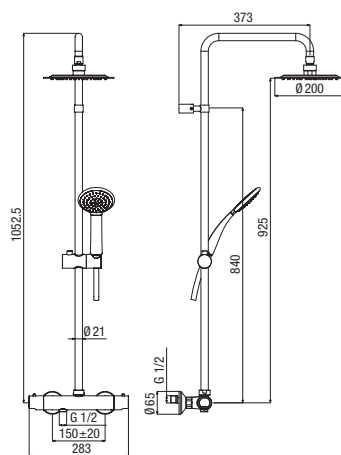

METAL

ø 21 mm



Il tubo della colonna doccia può essere tagliato
the riser of the shower column can be cut
 le tube de la colonne de douche peut être coupée



JO 97SM2151 CR

€ 477,00

colonna doccia termostatica
 - deviazione integrata
 - soffione 200x200 mm
 - doccia monogetto anticalcare
thermostatic shower column
 - integrated diverter
 - 200x200 mm shower head
 - one spray handset anti-scale
 colonne de douche thermostatique
 - inverseur intégré
 - pomme de douche 200x200 mm
 - douchette monojet anticalcaire

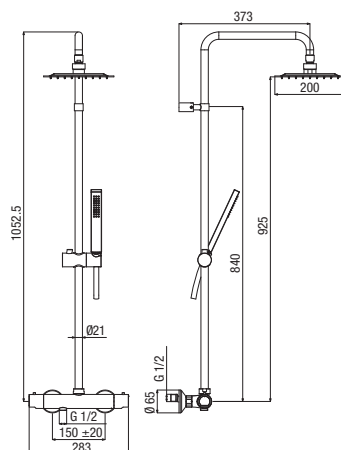

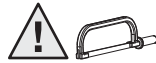
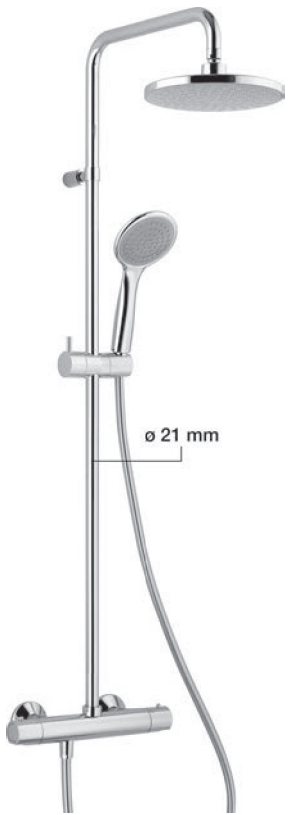

Il tubo della colonna doccia può essere tagliato
 the riser of the shower column can be cut
 le tube de la colonne de douche peut être coupée



JO 97RP2151 CR

€ 405,00

- colonna doccia termostatica
- deviazione integrata
 - soffione ø 200 mm
 - doccia monogetto anticalcare
- thermostatic shower column*
- integrated diverter
 - ø 200 mm shower head
 - one spray handset anti-scale
- colonne de douche thermostatique
- inverseur intégré
 - pomme de douche ø 200 mm
 - douchette monojet anticalcaire



CR 010NC



CR-107C

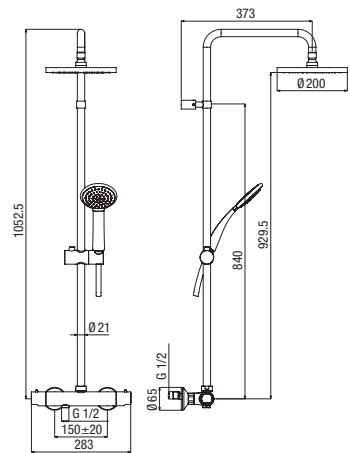

SPS 86RM2151 CR

€ 647,00

- colonna doccia termostatica
- deviazione integrata
 - soffione ø 200 mm
 - doccia monogetto anticalcare con sistema **AIRmix**
- thermostatic shower column*
- integrated diverter
 - ø 200 mm shower head
 - one spray handset anti-scale with **AIRmix** saving system
- colonne de douche thermostatique
- inverseur intégré
 - pomme de douche ø 200 mm
 - douchette monojet anticalcaire avec système **AIRmix**



CR 010NC



CR-150C

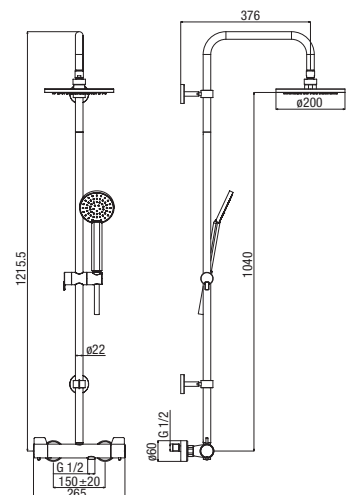

Colonne doccia

COLONNE DOCCIA TELESCOPICHE ADJUSTABLE SHOWER COLUMN COLONNES DE DOUCHE TELESCOPIQUE



SPL 72RP7151 CR

€ 534,00

colonna doccia termostatica
 - **telescopica**
 - deviazione integrata
 - soffione ø 200 mm
 - doccia monogetto anticalcare con sistema **AIRmix**

thermostatic shower column

- **adjustable**
 - *integrated diverter*
 - *ø 200 mm shower head*
 - *one spray handset anti-scale with AIRmix saving system*

colonne de douche thermostatique

- **télescopique**
 - inverseur intégré
 - pomme de douche ø 200 mm
 - douchette monojet anticalcaire avec système **AIRmix**

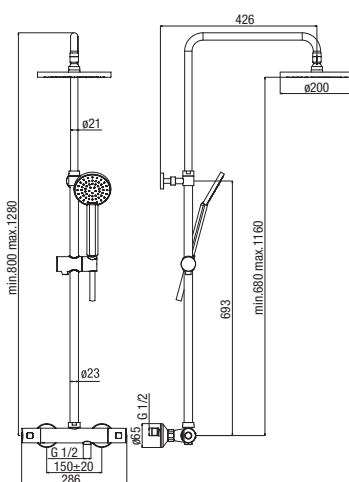

JO 97RM7151 CR

€ 496,00

colonna doccia termostatica
 - **telescopica**
 - deviazione integrata
 - soffione ø 200 mm
 - doccia monogetto anticalcare

thermostatic shower column

- **adjustable**
 - *integrated diverter*
 - *ø 200 mm shower head*
 - *one spray handset anti-scale*

colonne de douche thermostatique

- **télescopique**
 - inverseur intégré
 - pomme de douche ø 200 mm
 - douchette monojet anticalcaire

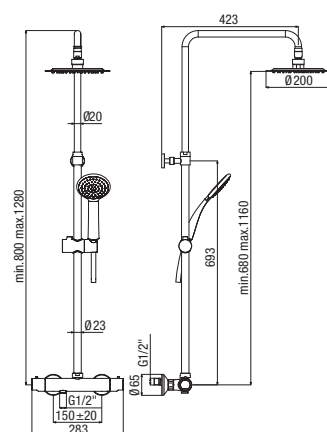



JO 97SM7151 CR

€ 526,00

colonna doccia termostatica

- **telescopica**
- deviazione integrata
- soffione 200x200 mm
- doccia monogetto anticalcare

thermostatic shower column

- **adjustable**
- *integrated diverter*
- *200x200 mm shower head*
- *one spray handset anti-scale*

colonne de douche thermostatique

- **télescopique**
- inverseur intégré
- pomme de douche 200x200 mm
- douchette monojet anticalcaire

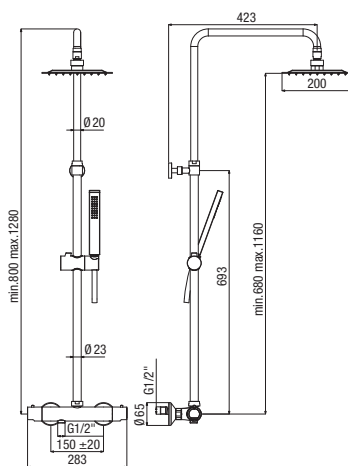

Colonne doccia universali

universal shower columns
colonne de douche universelle

Le colonne attacco universale, fornite con un kit di montaggio che permette di sostituire qualsiasi vecchia installazione (sia rubinetteria incasso che rubinetteria esterna), offrono la possibilità di **passare a 2 getti d'acqua (soffione + doccetta)** senza interventi di opere murarie.

The shower columns with universal connection system, supplied with a mounting kit that allows you to replace any old installation (both concealed and external solutions), they offer the option to upgrade to 2 water jets (shower head + handset) without the intervention of masonry.

Les colonnes de douche avec raccordement universel, fournies avec un kit de montage qui vous permet de remplacer une ancienne installation (robinetterie encastrée et robinetterie apparente), ils offrent la possibilité de **passer à 2 jets d'eau (douche de tête + douche à main)** sans l'intervention de maçonnerie.

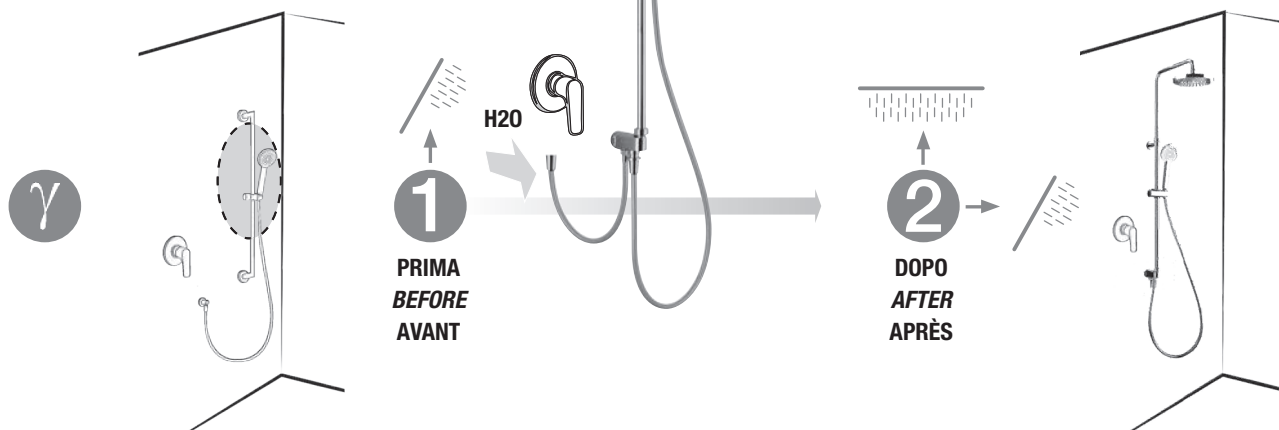
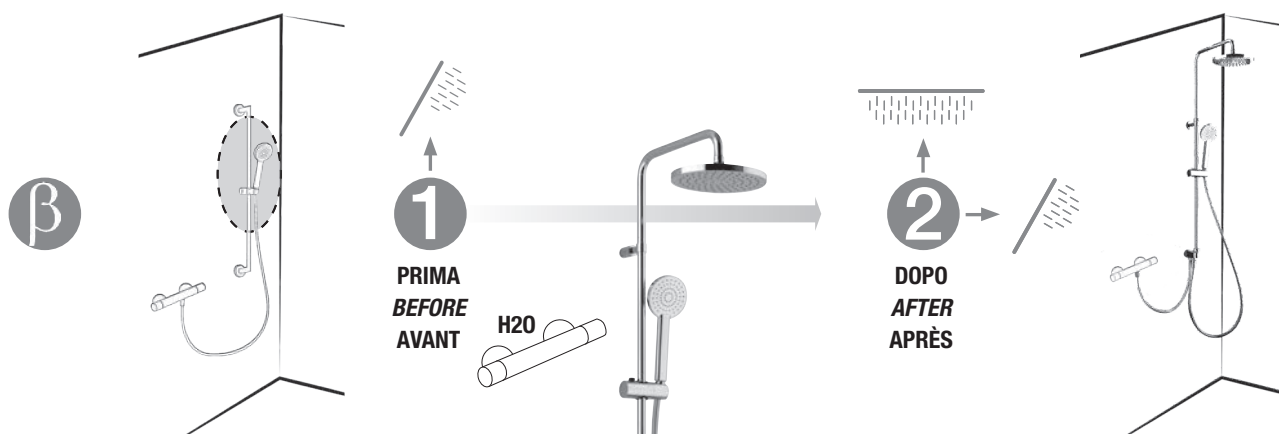
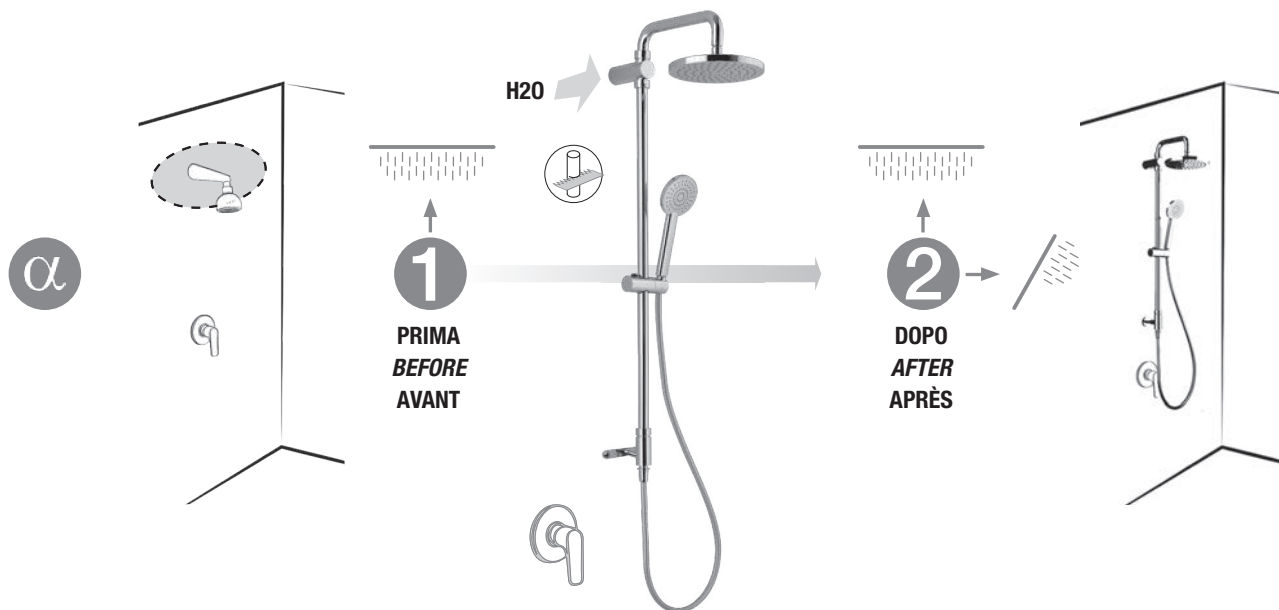

α

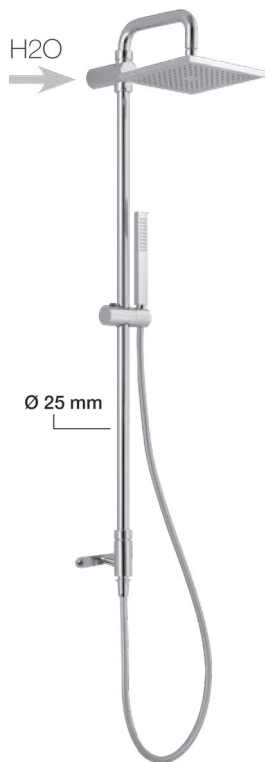

Il tubo della colonna doccia può essere tagliato
the riser of the shower column can be cut
 le tube de la colonne de douche peut être coupée

CD 77SP111 CR € 546,00

colonna doccia attacco universale
 alimentazione acqua superiore
 - deviatore integrato
 - soffione 200x200 mm
 - doccia monogetto
 - flessibile doccia PVC

*universal connection system shower column
 with bracket water outlet*
 - *integrated diverter*
 - *200x200 mm shower head*
 - *one spray handset*
 - *shower hose PVC*

colonne de douche support universel
 avec alimentation d'eau supérieur
 - inverseur intégré
 - pomme de douche 200x200 mm
 - douchette monojet
 - flexible de douche PVC

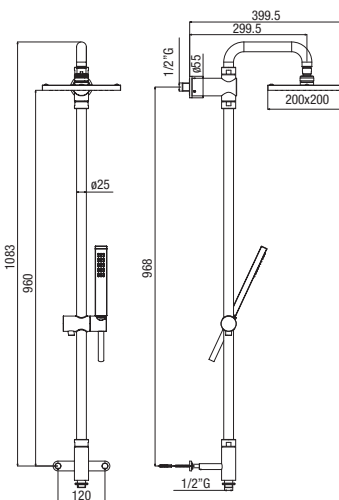

α

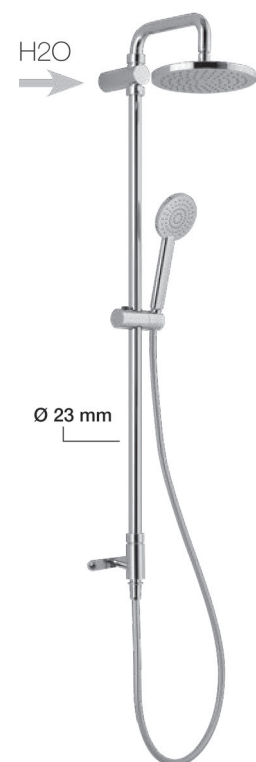

Il tubo della colonna doccia può essere tagliato
the riser of the shower column can be cut
 le tube de la colonne de douche peut être coupée

CD 77RP110 CR € 514,00

colonna doccia attacco universale
 alimentazione acqua superiore
 - deviatore integrato
 - soffione ø 200 mm
 - doccia monogetto anticalcare
 con sistema **AIRmix**
 - flessibile doccia PVC

*universal connection system shower column
 with bracket water outlet*
 - *integrated diverter*
 - *ø 200 mm shower head*
 - *one spray handset anti-scale*
 with **AIRmix** saving system
 - *shower hose PVC*

colonne de douche support universel
 avec alimentation d'eau supérieur
 - inverseur intégré
 - pomme de douche ø 200 mm
 - douchette monojet anticalcaire
 avec système **AIRmix**
 - flexible de douche PVC

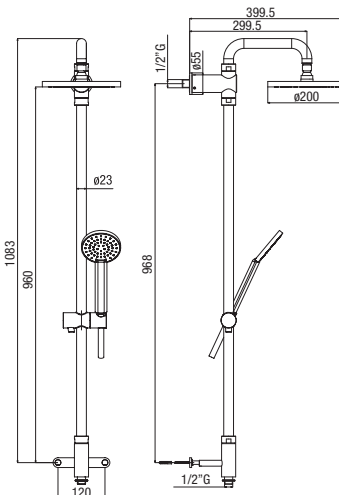

Colonne doccia universali

universal shower columns
colonnes de douche universelle

β

γ

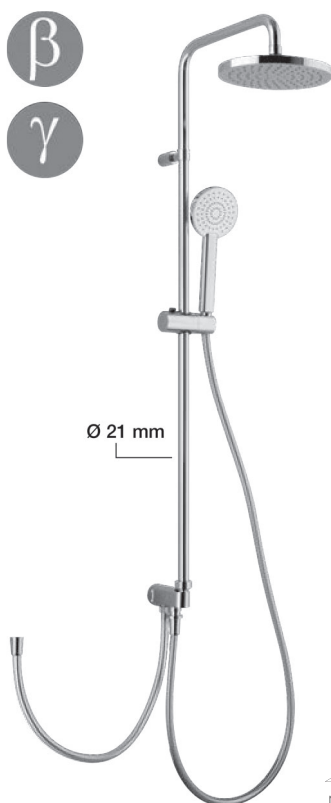

Ø 21 mm



Il tubo della colonna doccia può essere tagliato
the riser of the shower column can be cut
le tube de la colonne de douche peut être coupée

CD 60RP108 CR

€ 270,00

- colonna doccia
- deviatore integrato
 - soffione ø 200 mm
 - doccia monogetto con sistema **AIRmix**
 - flessibile doccia PVC
 - flessibile di collegamento cm 60
 - kit di montaggio universale

shower column

- integrated diverter,
- ø 200 mm shower head
- one spray handset **AIRmix** saving system
- shower hose PVC
- connection hose 60 cm
- universal assembly kit

colonne de douche

- inverseur intégré,
- pomme de douche ø 200 mm
- douchette monojet avec système **AIRmix**
- flexible de douche PVC
- flexible d'alimentation 60 cm

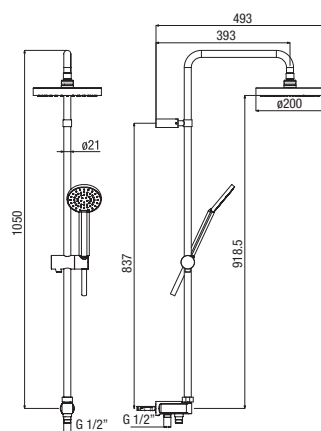

β

γ

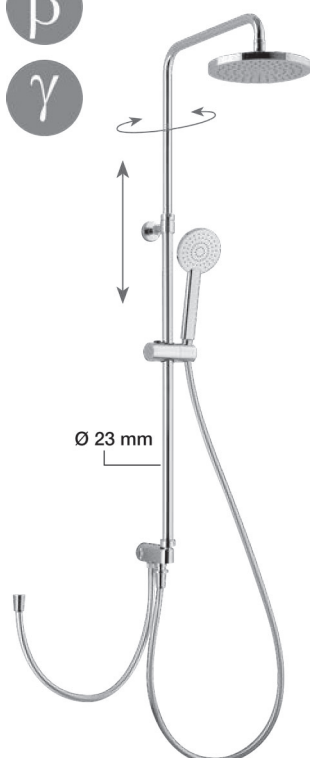

Ø 23 mm

CD 60RP708 CR

€ 314,00

colonna doccia **telescopica**

- deviatore integrato
- soffione ø 200 mm
- doccia monogetto con sistema **AIRmix**
- flessibile doccia PVC
- flessibile di collegamento cm 60
- kit di montaggio universale

adjustable shower column

- integrated diverter
- ø 200 mm shower head
- one spray handset **AIRmix** saving system
- shower hose PVC
- connection hose 60 cm
- universal assembly kit

colonne de douche **télescopique**

- inverseur intégré
- pomme de douche ø 200 mm
- douchette monojet avec système **AIRmix**
- flexible de douche PVC
- flexible d'alimentation 60 cm

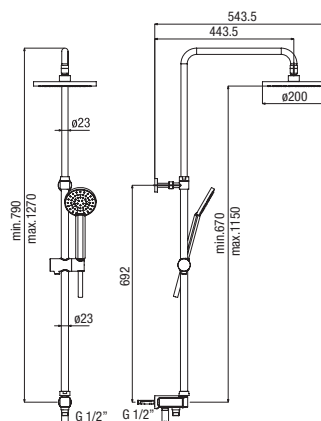

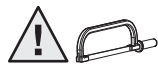

Il tubo della colonna doccia può essere tagliato
the riser of the shower column can be cut
 le tube de la colonne de douche peut être coupée

CD 60SP109 CR € 302,00

- colonna doccia
- deviatore integrato
 - soffione 200x200 mm
 - doccia monogetto con sistema **AIRmix**
 - flessibile doccia PVC
 - flessibile di collegamento cm 60
 - kit di montaggio universale

- shower column*
- *integrated diverter,*
 - *200x200 mm shower head*
 - *one spray handset AIRmix saving system*
 - *shower hose PVC*
 - *connection hose 60 cm*
 - *universal assembly kit*

- colonne de douche
- inverseur intégré,
 - pomme de douche 200x200 mm
 - douchette monojet avec système **AIRmix**
 - flexible de douche PVC
 - flexible d'alimentation 60 cm

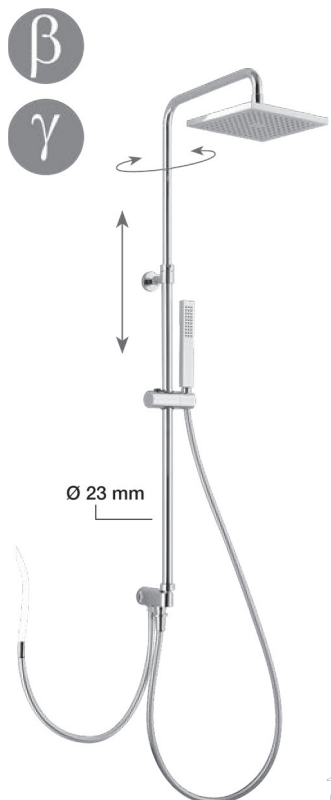
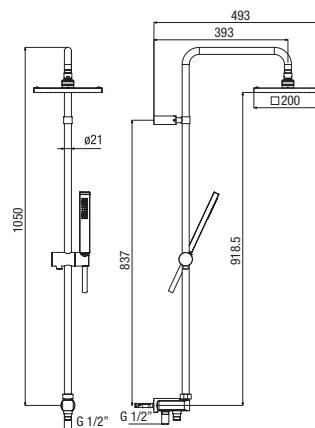

CD 60SP709 CR € 345,00

- colonna doccia **telescopica**
- deviatore integrato
 - soffione 200x200 mm
 - doccia monogetto con sistema **AIRmix**
 - flessibile doccia PVC
 - flessibile di collegamento cm 60
 - kit di montaggio universale

- adjustable shower column*
- *integrated diverter*
 - *200x200 mm shower head*
 - *one spray handset AIRmix saving system*
 - *shower hose PVC*
 - *connection hose 60 cm*
 - *universal assembly kit*

- colonne de douche **télescopique**
- inverseur intégré,
 - pomme de douche 200x200 mm
 - douchette monojet avec système **AIRmix**
 - flexible de douche PVC
 - flexible d'alimentation 60 cm

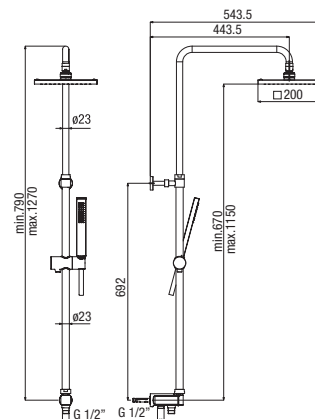

Colonne doccia per la ristrutturazione

shower columns for renovation

colonnes de douche pour renovation





ideale per spazi ridotti
ideal for small spaces
idéal pour les espaces petits



PROtherm

ECI 75RP2151 CR

€ 641,00

- colonna doccia termostatica
- deviazione integrata
 - soffione ø 200 mm
 - doccia monogetto con sistema **AIRmix**
- thermostatic shower column
- integrated diverter
 - 200 mm shower head
 - one spray handset **AIRmix** saving system
- colonne de douche thermostatique
- inverseur intégré
 - pomme de douche ø 200 mm
 - douchette monojet avec système **AIRmix**

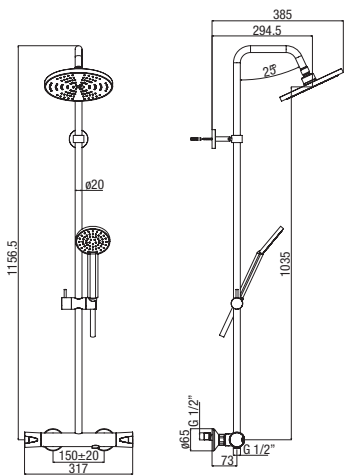

La lunghezza del braccio doccia è contenuta per ottimizzare lo spazio ridotto disponibile.

The length of the shower arm is reduced to optimize the small space available.

La longueur du bras douche est contenue pour optimiser l'espace réduit disponible.



Colonne doccia per la ristrutturazione

shower columns for renovation

colonnes de douche pour renovation

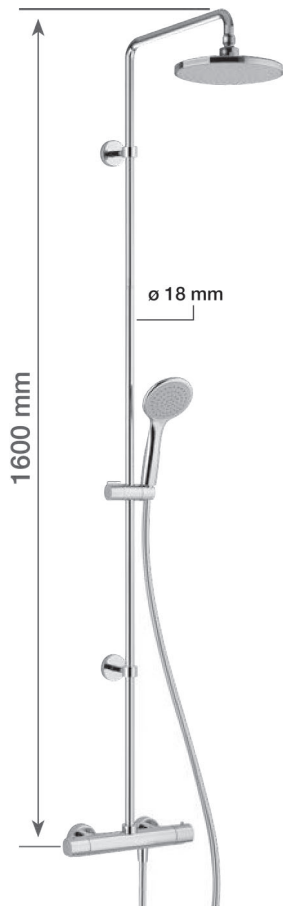

ideale per trasformazione da vasca in doccia
ideal for transformation from bathroom into shower
 idéal pour la transformation de la baignoire à la douche

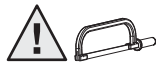

Il tubo della colonna doccia può essere tagliato
the riser of the shower column can be cut
 le tube de la colonne de douche peut être coupée



JO 74RP3151 CR

€ 528,00

colonna doccia termostatica con asta prolungata

ideale per ristrutturazione

- deviazione integrata
- soffione ø 200 mm
- doccia monogetto anticalcare

thermostatic shower column with longer shower pipe
ideal for renovation

- integrated diverter
- ø 200 mm shower head
- one spray anti-scale handset

colonne de douche thermostatique avec tube plus long
 idéal pour la rénovation

- inverseur intégré
- pomme de douche ø 200 mm
- douchette monojet anticalcaire

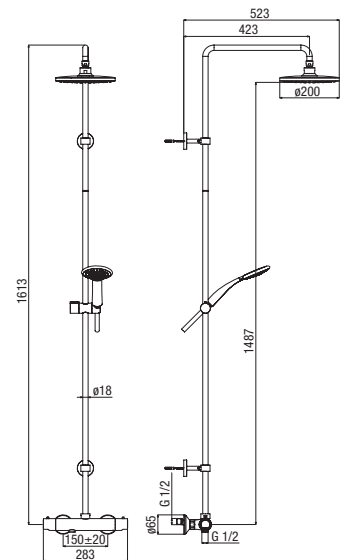

Sfruttando i **vecchi attacchi acqua** otteniamo l'altezza ottimale del soffione doccia grazie al riser più lungo degli standard (normalmente una colonna doccia è alta 110 cm e viene posizionata a 120 cm)

Using **the previous water connections** we obtain the optimal height of the shower head thanks to the riser longer than standard ones (usually a shower column is 110 cm tall and is positioned at 120 cm).

Utilisant **les anciennes connexions eau** on obtient la hauteur optimale de la pomme de douche grâce au riser plus long par rapport à celui standard (normalement une colonne douche est haute 110 cm et est positionnée à 120 cm).

prima before avant

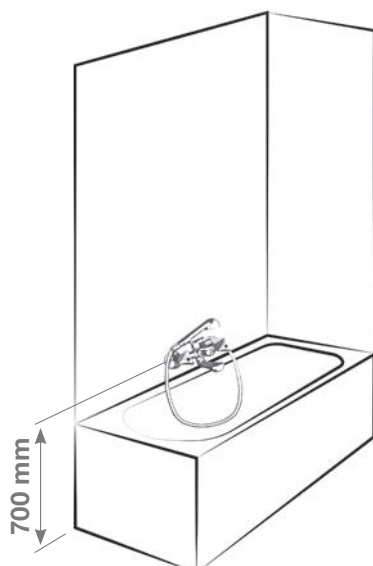

dopo after après

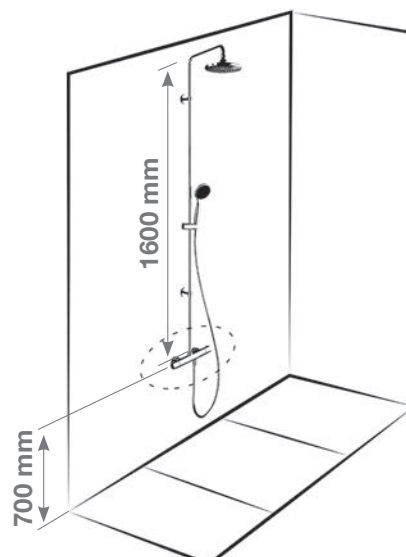



vasca/doccia
bath&shower
bain&douche

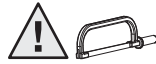

Il tubo della colonna doccia può essere tagliato
the riser of the shower column can be cut
le tube de la colonne de douche peut être coupée



CPL 87RM4151 CR € 790,00

colonna vasca/doccia termostatica
- deviazione integrata
- soffione ø 200 mm
- doccia monogetto anticalcare

thermostatic bath&shower column
- *integrated diverter*
- *ø 200 mm shower head*
- *one spray anti-scale handset*

colonne thermostatique bain&douche
- inverseur intégré
- pomme de douche ø 200 mm
- douchette monojet anticalcaire

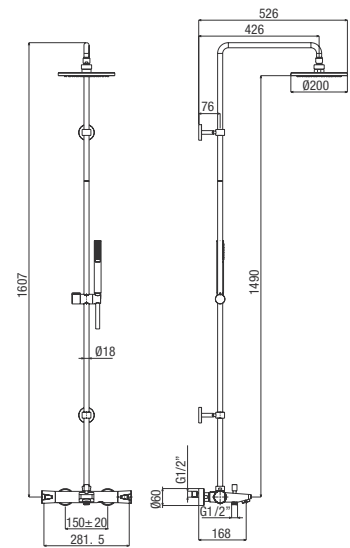

Sostituendo il vecchio gruppo vasca con la colonna vasca/doccia termostatica si aumenta il comfort in quanto si hanno a disposizione 3 uscite acqua con il soffione doccia ø 200 mm.

Replacing the previous bath shower mixer with the thermostatic bath&shower column comfort is enhanced since there are 3 water outlets available with shower head ø 200 mm.

En remplaçant l'ancien bain douche avec la colonne thermostatique bain&douche le confort augmente car on a 3 sorties eau disponibles avec la pomme de douche ø 200 mm.

prima before avant

dopo after après

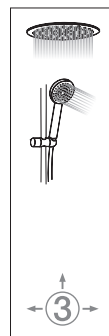
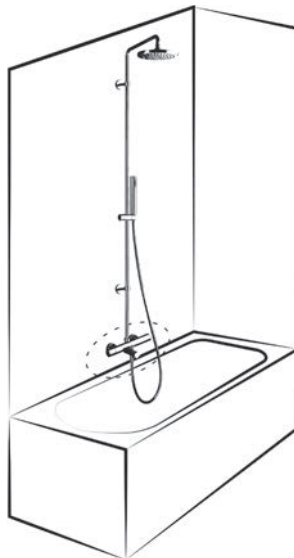
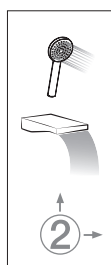
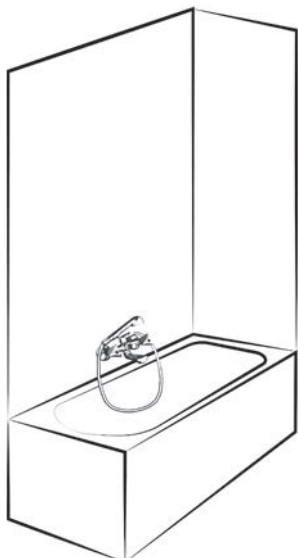

Shower set

Una selezione di kit ad incasso termostatica e meccanica completa di accessori, con un rapporto qualità/prezzo vantaggioso in grado di soddisfare ogni esigenza.

A selection of concealed thermostatic and single-lever kit complete with accessories, with an advantageous quality/price ratio that will satisfy every need.

Une sélection de kit à encastrer thermostatique et mécanique complète avec accessoires, avec une rapport qualité / prix avantageuse qui sera satisfaire tous les besoins.



Shower set

SHOWER SET MONOCOMANDO SINGLE-LEVER SHOWER SET SHOWER SET MONOCOMMANDE

CPL 87863 CR
SF 060 CR
BD 035 CR
KI 060 CR



SWK 87A1863 CR

€ 288,00

monocomando doccia incasso
con deviatore meccanico
- braccio doccia 350 mm G1/2"
- soffione doccia anticalcare \varnothing 200 mm
- doccia monogetto anticalcare
con sistema **AIRmix**

- supporto doccia con presa acqua
- flessibile doccia PVC
*concealed single-lever shower mixer
with mechanical diverter*
- shower arm 350 mm G1/2"
- \varnothing 200 mm shower head, anti-scale
- one-spray handset, anti-scale,
AIRmix saving system
- shower bracket with water outlet
- shower hose PVC

douche encastré monocommande
avec inverseur mécanique
- bras de douche 350 mm G1/2"
- pomme de douche \varnothing 200 mm, anticalcaire
- douchette monojet anticalcaire
avec système **AIRmix**
- support douchette avec prise eau
- flexible de douche PVC

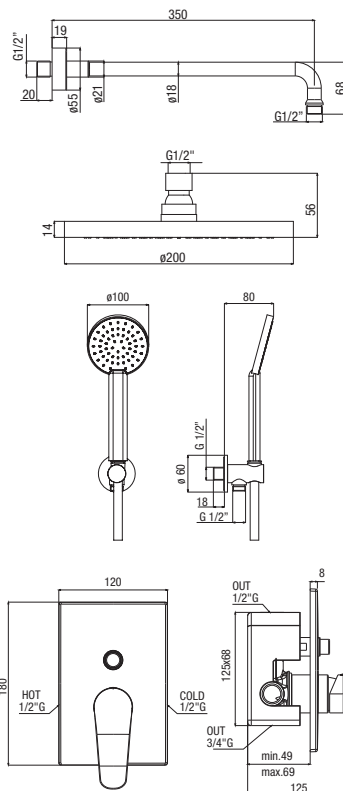

SPL 72A863 CR
SF 074A CR
BD 035 CR
KI 103 CR

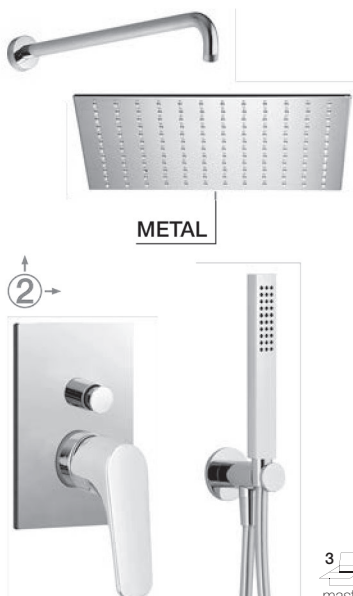

METAL



SWK 72A1863 CR

€ 380,00

monocomando doccia incasso
con deviatore meccanico
- braccio doccia 350 mm G1/2"
- soffione doccia 250x250 mm
- doccia monogetto anticalcare
- supporto doccia con presa acqua
- flessibile doccia PVC

*concealed single-lever shower mixer
with mechanical diverter*
- shower arm 350 mm G1/2"
- 250x250 mm shower head
- one-spray handset, anti-scale
- shower bracket with water outlet
- shower hose PVC

douche encastré monocommande
avec inverseur mécanique
- bras de douche 350 mm G1/2"
- pomme de douche 250x250 mm
- douchette monojet anticalcaire
- support douchette avec prise eau
- flexible de douche PVC

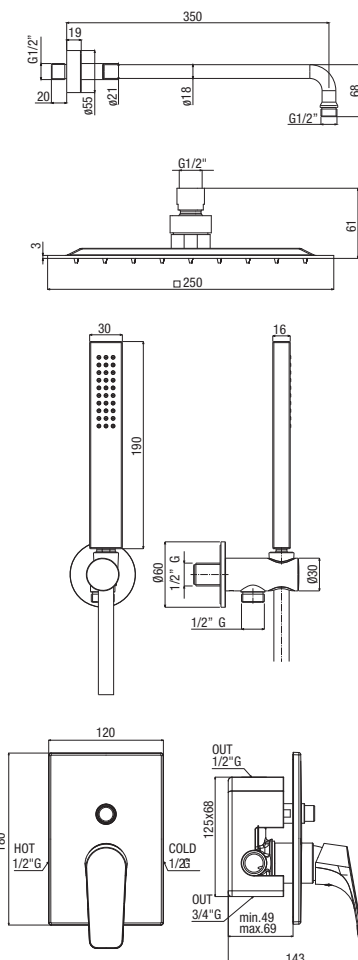

JO 74863 CR
SF 101A CR
BD 035 CR
KI 060 CR



SWK 741863 CR

€ 320,00

monocomando doccia incasso con deviatore meccanico

- braccio doccia 350 mm G1/2"
- soffione doccia ø 200 mm
- doccia monogetto anticalcare

con sistema **AIRmix**

- supporto doccia con presa acqua
- flessibile doccia PVC

concealed single-lever shower mixer with mechanical diverter

- shower arm 350 mm G1/2"
- ø 200 mm shower head
- one-spray handset, anti-scale,

AIRmix saving system

- shower bracket with water outlet
- shower hose PVC

douche encastré monocommande avec inverseur mécanique

- bras de douche 350 mm G1/2"
- pomme de douche ø 200 mm
- douchette monojet anticalcaire

avec système **AIRmix**

- support douchette avec prise eau
- flexible de douche PVC

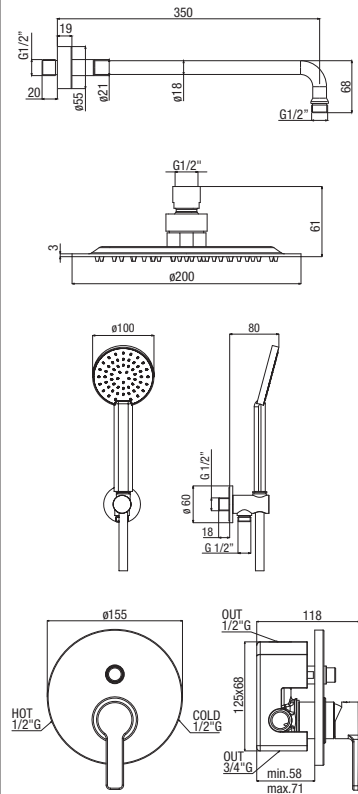

Shower set

SHOWER SET TERMOSTATICI THERMOSTATIC SHOWER SET SHOWER SET THERMOSTATIQUE

CPL 87163 CR
SF 060 CR
BD 035 CR
KI 060 CR



SWK 871163 CR

€ 563,00

termostatico doccia incasso con deviatore ceramico

- due uscite** e regolazione portata
- braccio doccia 350 mm G1/2"
 - soffione doccia anticalcare \varnothing 200 mm
 - doccia monogetto anticalcare con sistema **AIRmix**
 - supporto doccia con presa acqua
 - flessibile doccia PVC

concealed thermostatic shower valve with two outlets ceramic diverter and stop

- shower arm 350 mm G1/2"
- \varnothing 200 mm shower head, anti-scale
- one-spray handset, anti-scale, **AIRmix** saving system
- shower bracket with water outlet
- shower hose PVC

douche thermostatique encastré avec sélecteur céramique **deux sorties**

- bras de douche 350 mm G1/2"
- pomme de douche \varnothing 200 mm, anticalcaire
- douchette monojet anticalcaire avec système **AIRmix**
- support douchette avec prise eau
- flexible de douche PVC

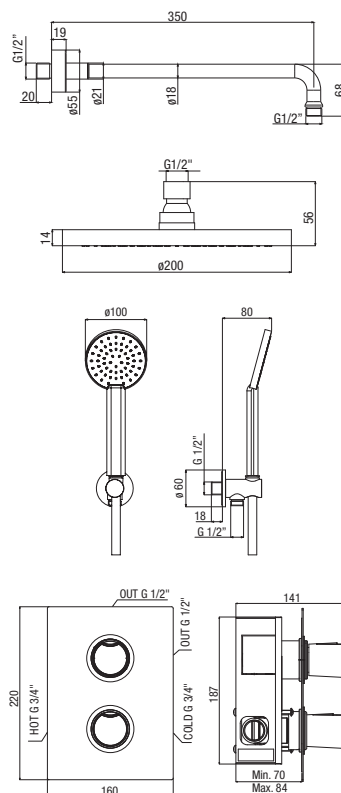

CPL 87163 CR
SF 074A CR
BD 035 CR
KI 103 CR

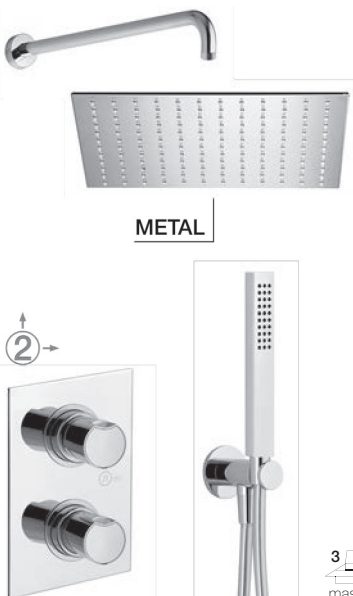

SWK 872163 CR

€ 653,00

termostatico doccia incasso con deviatore ceramico

- due uscite** e regolazione portata
- braccio doccia 350 mm G1/2"
 - soffione doccia anticalcare \varnothing 200 mm
 - doccia monogetto anticalcare
 - supporto doccia con presa acqua
 - flessibile doccia PVC

concealed thermostatic shower valve with two outlets ceramic diverter and stop

- shower arm 350 mm G1/2"
- \varnothing 200 mm shower head, anti-scale
- one-spray handset, anti-scale
- shower bracket with water outlet
- shower hose PVC

douche thermostatique encastré avec sélecteur céramique **deux sorties**

- bras de douche 350 mm G1/2"
- pomme de douche \varnothing 200 mm, anticalcaire
- douchette monojet anticalcaire
- support douchette avec prise eau
- flexible de douche PVC

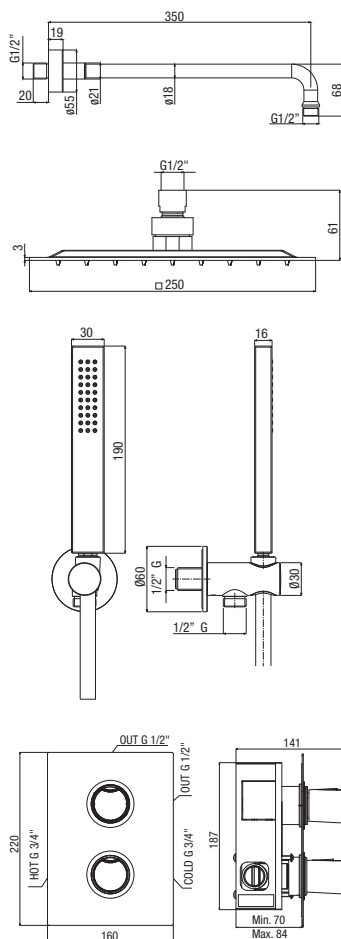

SPL 72163 CR
SF 101A CR
BD 035 CR
KI 060 CR



SWK 721163 CR

€ 574,00

termostatico doccia incasso con deviatore ceramico **due uscite** e regolazione portata

- braccio doccia 350 mm G1/2"
- soffione doccia anticalcare ø 200 mm
- doccia monogetto anticalcare

con sistema **AIRmix**

- supporto doccia con presa acqua
- flessibile doccia PVC

concealed thermostatic shower valve with two outlets ceramic diverter and stop

- shower arm 350 mm G1/2"
- ø 200 mm shower head, anti-scale
- one-spray handset, anti-scale,

AIRmix saving system

- shower bracket with water outlet
- shower hose PVC

douche thermostatique encastré avec sélecteur céramique **deux sorties**

- bras de douche 350 mm G1/2"
- pomme de douche ø 200 mm, anticalcaire
- douchette monojet anticalcaire

avec système **AIRmix**

- support douchette avec prise eau
- flexible de douche PVC

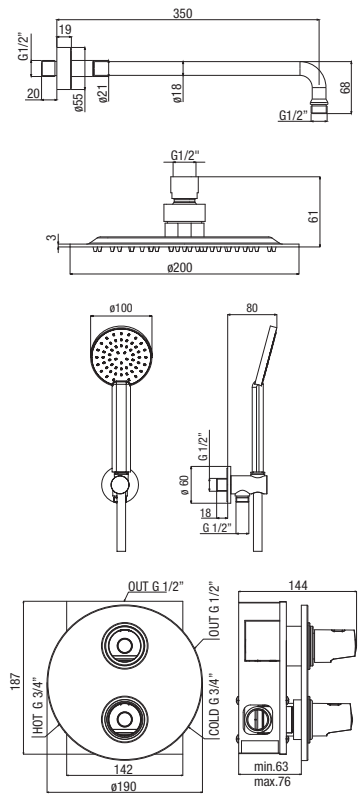

Idroterapia



Metal slim

SOFFIONI DOCCIA SHOWER HEADS POMME DE DOUCHE

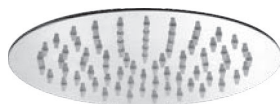

SF 101A CR

€ 82,00

soffione doccia ø 200 mm **METAL SLIM**
 ø 200 mm shower head **METAL SLIM**
 pomme de douche ø 200 mm **METAL SLIM**

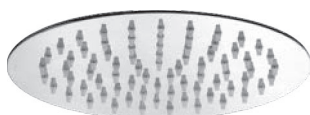
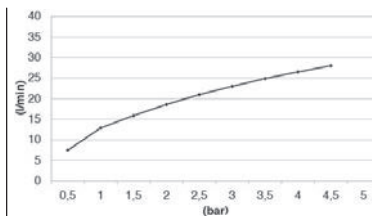
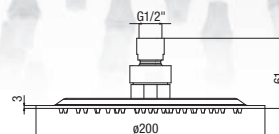

SF 073A CR

€ 127,00

soffione doccia ø 250 mm **METAL SLIM**
 ø 250 mm shower head **METAL SLIM**
 pomme de douche ø 250 mm **METAL SLIM**

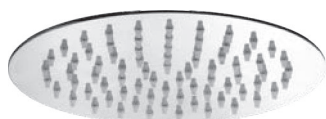
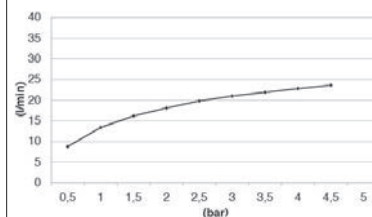
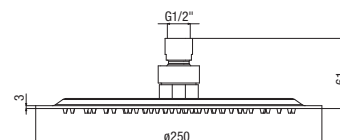

SF 075A CR

€ 175,00

soffione doccia ø 300 mm **METAL SLIM**
 ø 300 mm shower head **METAL SLIM**
 pomme de douche ø 300 mm **METAL SLIM**

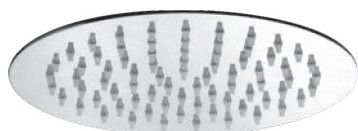
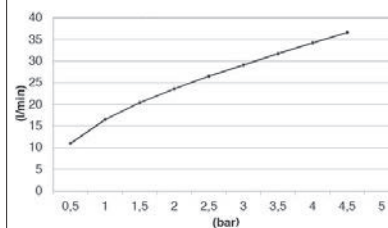
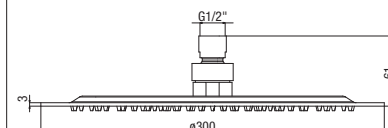

SF 083A CR

€ 260,00

soffione doccia ø 400 mm **METAL SLIM**
 ø 400 mm shower head **METAL SLIM**
 pomme de douche ø 400 mm **METAL SLIM**

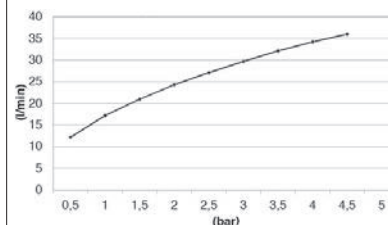
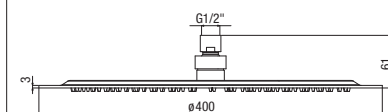



SF 102A CR

€ 100,00

soffione doccia 200x200 mm **METAL SLIM**
 200x200 mm shower head **METAL SLIM**
 pomme de douche 200x200 mm **METAL SLIM**

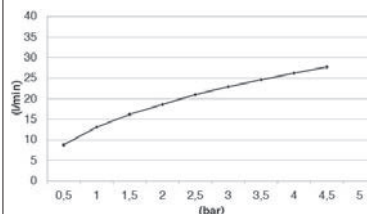
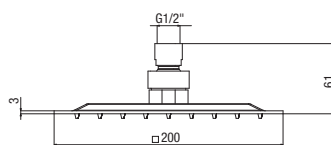

SF 074A CR

€ 151,00

soffione doccia 250x250 mm **METAL SLIM**
 250x250 mm shower head **METAL SLIM**
 pomme de douche 250x250 mm **METAL SLIM**

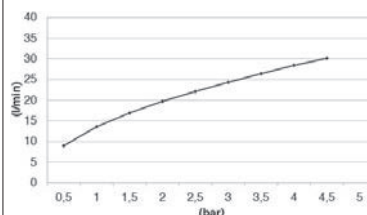
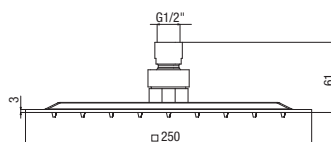

SF 076A CR

€ 199,00

soffione doccia 300x300 mm **METAL SLIM**
 300x300 mm shower head **METAL SLIM**
 pomme de douche 300x300 mm **METAL SLIM**

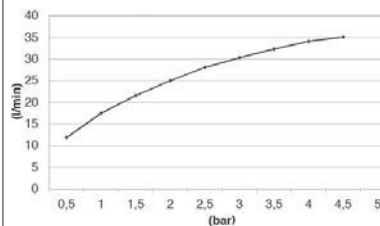
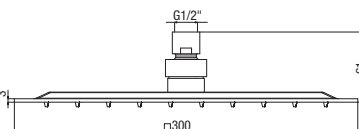

SF 114A CR

€ 290,00

soffione doccia 400x400 mm **METAL SLIM**
 400x400 mm shower head **METAL SLIM**
 pomme de douche 400x400 mm **METAL SLIM**

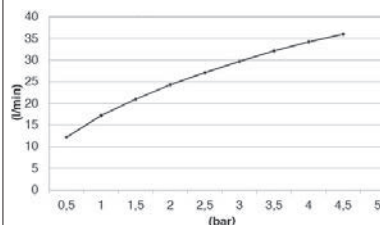
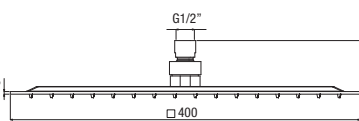

Metal

SOFFIONI DOCCIA SHOWER HEADS POMME DE DOUCHE



SF 066A CR

€ 99,00



soffione doccia \varnothing 200 mm **METAL**
 \varnothing 200 mm shower head **METAL**
 pomme de douche \varnothing 200 mm **METAL**

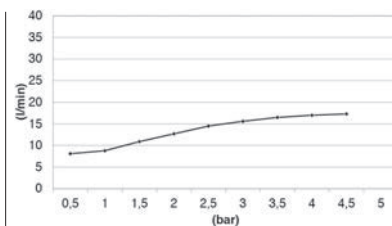
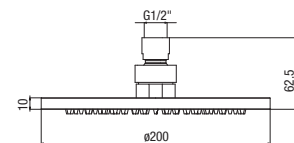

SF 067A CR

€ 145,00



soffione doccia \varnothing 250 mm **METAL**
 \varnothing 250 mm shower head **METAL**
 pomme de douche \varnothing 250 mm **METAL**

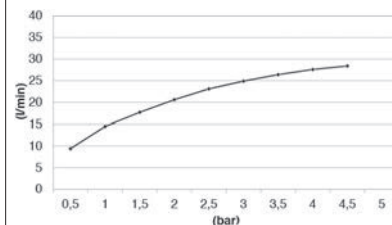
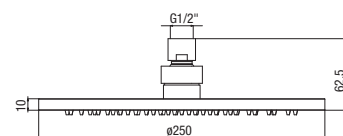

SF 069A CR

€ 199,00



soffione doccia \varnothing 300 mm **METAL**
 \varnothing 300 mm shower head **METAL**
 pomme de douche \varnothing 300 mm **METAL**

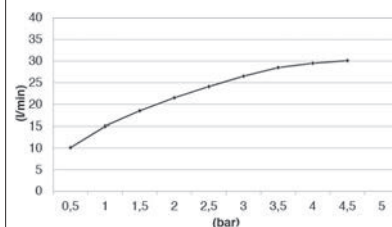
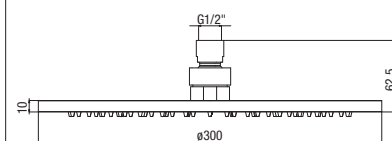



SF 068A CR

€ 163,00

soffione doccia 250x250 mm **METAL**
 250x250 mm shower head **METAL**
 pomme de douche 250x250 mm **METAL**

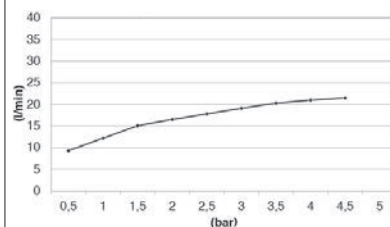
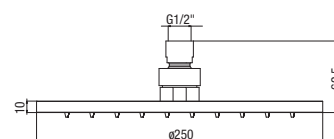

SF 070A CR

€ 223,00

soffione doccia 300x300 mm **METAL**
 300x300 mm shower head **METAL**
 pomme de douche 300x300 mm **METAL**

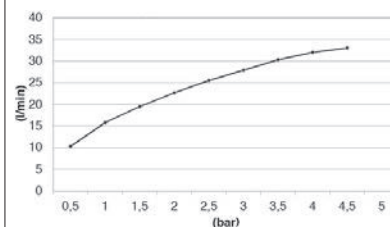
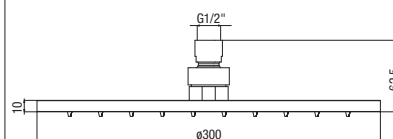

ABS

SOFFIONI DOCCIA SHOWER HEADS POMME DE DOUCHE



SF 085 CR

€ 32,00

soffione doccia ø 200 mm **diffusore grigio**
 ø 200 mm shower head **grey face**
 pomme de douche ø 200 mm **diffuseur gris**

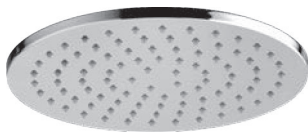
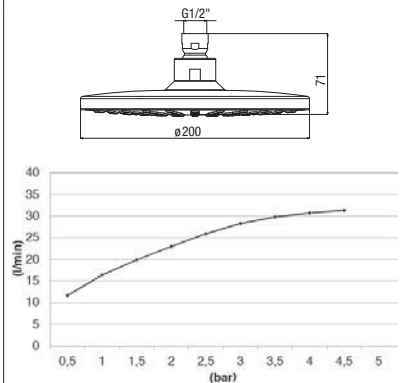

SF 077 CR

€ 40,00

soffione doccia ø 200 mm **diffusore grigio**
 ø 200 mm shower head **grey face**
 pomme de douche ø 200 mm **diffuseur gris**

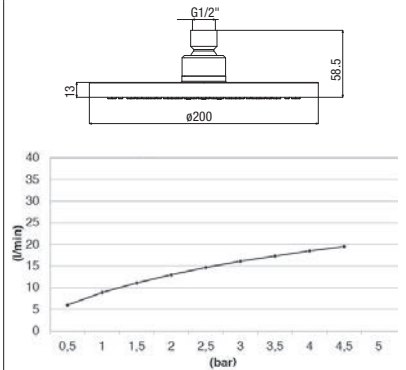

SF 060 CR

€ 46,00

soffione doccia ø 200 mm **ABS**
 ø 200 mm shower head **ABS**
 pomme de douche ø 200 mm **ABS**

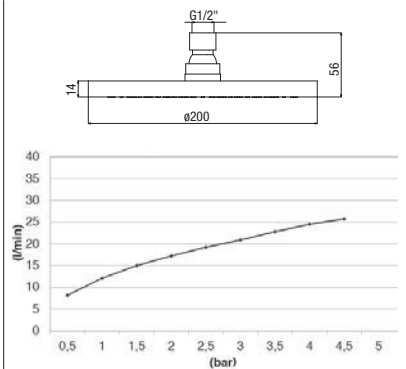

SF 064 CR

€ 66,00

soffione doccia ø 250 mm **ABS**
 ø 250 mm shower head **ABS**
 pomme de douche ø 250 mm **ABS**

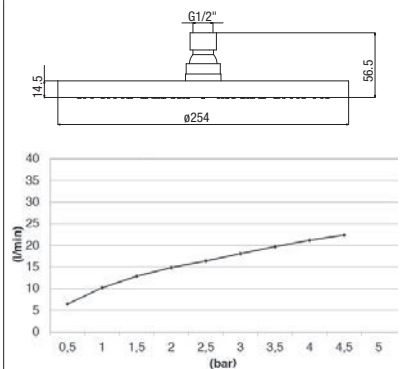



SF 063 CR

€ 53,00

soffione doccia 200x200 mm **ABS**
 200x200 mm shower head **ABS**
 pomme de douche 200x200 mm **ABS**

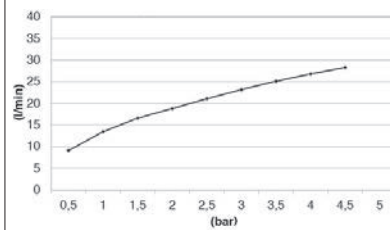
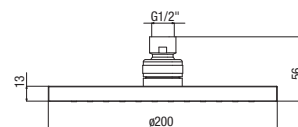

SF 084 CR

€ 78,00

soffione doccia 250x250 mm **ABS**
 250x250 mm shower head **ABS**
 pomme de douche 250x250 mm **ABS**

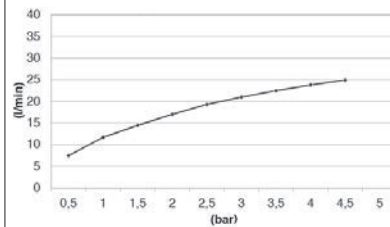
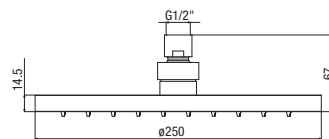

Idroterapia

SOFFIONI DOCCIA SHOWER HEADS POMME DE DOUCHE



SF 113 CR

€ 49,00

soffione antivandalo attacco in **ottone**
anti-vandal shower head, brass connection
 pomme de douche anti-vandal, raccord en **laiton**

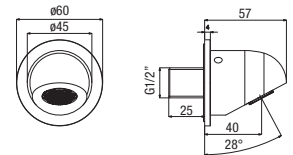

BRACCI DOCCIA SHOWER ARMS BRAS DE DOUCHE



BD 029 CR

€ 46,00

braccio doccia a soffitto 200 mm
ceiling shower arm 200 mm
 bras de douche à plafond 200 mm

BD 040 CR

€ 40,00

braccio doccia a soffitto 100 mm
ceiling shower arm 100 mm
 bras de douche à plafond 100 mm

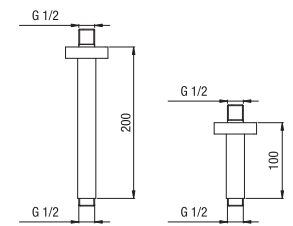

BD 047 CR

€ 69,00

braccio doccia a soffitto 100 mm
ceiling shower arm 100 mm
 bras de douche à plafond 100 mm

BD 048 CR

€ 81,00

braccio doccia a soffitto 200 mm
ceiling shower arm 200 mm
 bras de douche à plafond 200 mm

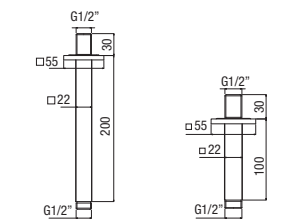

BD 034 CR

€ 46,00

braccio doccia 300 mm G1/2"
shower arm 300 mm G1/2"
 bras de douche 300 mm G1/2"

BD 035 CR

€ 52,00

braccio doccia 350 mm G1/2"
shower arm 350 mm G1/2"
 bras de douche 350 mm G1/2"

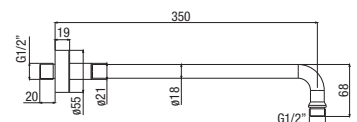
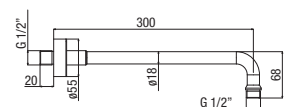



BD 039 CR

€ 91,00

braccio doccia 350 mm ø 24 mm
shower arm 350 mm ø 24 mm
 bras de douche 350 mm ø 24 mm

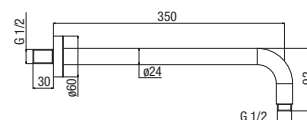

BD 036 CR

€ 99,00

braccio doccia 350 mm 22x22 mm G1/2"
shower arm 350 mm 22x22 mm G1/2"
 bras de douche 350 mm 22x22 mm G1/2"

BD 037 CR

€ 118,00

braccio doccia 430 mm 22x22 mm G1/2"
shower arm 430 mm 22x22 mm G1/2"
 bras de douche 430 mm 22x22 mm G1/2"

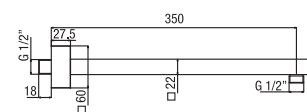

BD 038 CR

€ 84,00

braccio doccia 400 mm ø 24 mm G1/2"
shower arm 400 mm ø 24 mm G1/2"
 bras de douche 400 mm ø 24 mm G1/2"

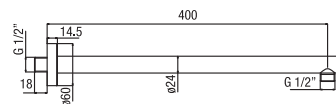

KI 082 CR

€ 115,00

kit braccio doccia 300 mm G1/2"
 e soffione ø 200 mm
kit shower arm 300 mm G1/2"
and shower head ø 200 mm
 kit bras de douche 300 mm G1/2"
 et pomme de douche ø 200 mm

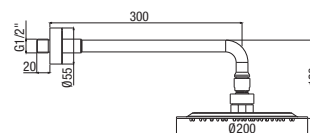

Idroterapia



KI 083 CR

€ 131,00

kit braccio doccia 300 mm G1/2"
e soffione 200x200 mm

*kit shower arm 300 mm G1/2"
and shower head 200x200 mm*

kit bras de douche 300 mm G1/2"
et pomme de douche 200x200 mm

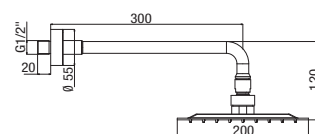

KI 062 CR

€ 88,00

kit braccio doccia 350 mm G1/2"
e soffione ø 200 mm, diffusore cromo

*kit shower arm 350 mm G1/2"
and shower head ø 200 mm, chrome face*

kit bras de douche 350 mm G1/2"
et pomme de douche ø 200 mm, diffuseur chromé

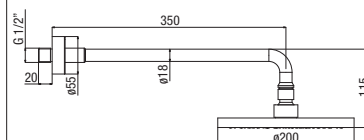

KI 063 CR

€ 94,00

kit braccio doccia 350 mm G1/2"
e soffione 200X200 mm, **diffusore cromo**

*kit shower arm 350 mm G1/2"
and shower head 200X200 mm, **chrome face***

kit bras de douche 350 mm G1/2"
et pomme de douche 200X200 mm, **diffuseur chromé**

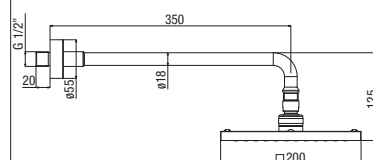

KIT SALISCENDI SLIDE RAIL KIT KIT BARRE DE DOUCHE



KI 080 CR

€ 85,00

kit saliscendi, asta 60 cm con portasapone, doccia **tre getti** anticalcare a pulsante e flessibile doccia PVC

*slide rail kit, 60 cm tube with soap dish, **three spray** anti-scale handset with press button and shower hose PVC*



kit barre de douche, barre 60 cm avec porte savon, douchette anticalcaire **trois jets** sélection à bouton et flexible PVC

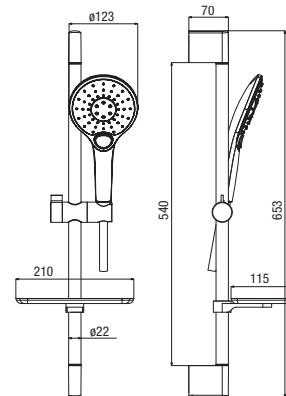

KI 081 CR

€ 89,00

kit saliscendi, asta 60 cm con portasapone doccia **tre getti** anticalcare a pulsante, flessibile doccia PVC

*slide rail kit, 60 cm tube with soap dish **three spray** anti-scale handset with press button, shower hose PVC*



kit barre de douche, barre 60 cm avec porte savon douchette anticalcaire **trois jets** sélection à bouton, flexible PVC

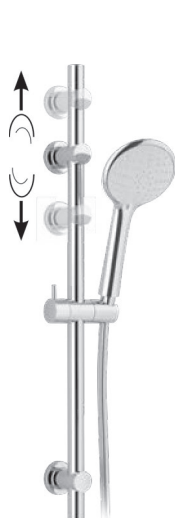
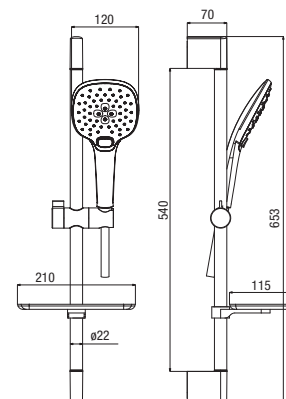

Ø 105 mm



KI 086 CR

€ 69,00

kit saliscendi, asta 70 cm con supporto regolabile, doccia **tre getti** e flessibile doccia PVC

*slide rail kit, 70 cm tube with adjustable bracket **three spray** anti-scale handset, shower hose PVC*



kit barre de douche, barre 70 cm avec support réglable douchette anticalcaire **trois jets** flexible PVC

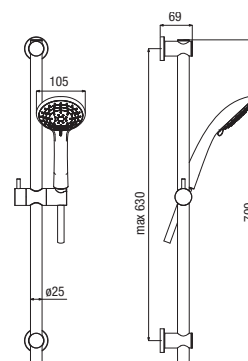

Idroterapia



KI 093 CR

€ 98,00

kit saliscendi, asta 70 cm, doccia monogetto anticalcare e flessibile doccia PVC

slide rail kit, 70 cm tube, one spray anti-scale handset, shower hose PVC



kit barre de douche, barre 70 cm, douchette monojet anticalcaire, flexible PVC

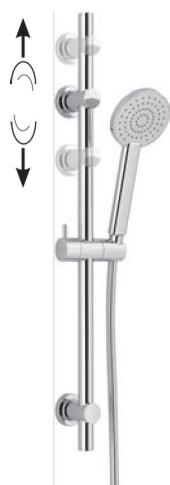
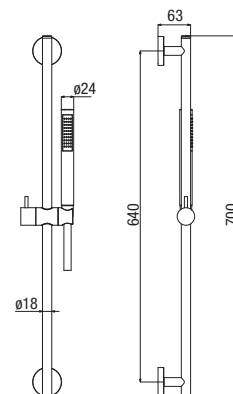

KI 041 CR

€ 66,00

kit saliscendi, asta 70 cm con supporto regolabile, doccia monogetto anticalcare con sistema **AIRmix** flessibile doccia PVC

slide rail kit, 70 cm tube with adjustable bracket, one spray handset anti-scale AIRmix saving system shower hose PVC



kit barre de douche, barre 70 cm avec support réglable douchette monojet anticalcaire avec système **AIRmix** flexible PVC

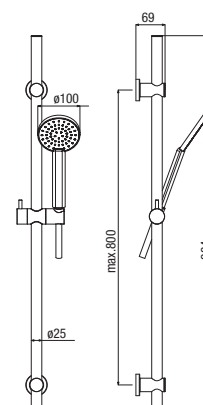

KI 044 CR

€ 59,00

kit saliscendi, asta 60 cm, doccia monogetto anticalcare con sistema **AIRmix**, flessibile doccia PVC

Slide rail kit, 60 cm tube, one spray handset anti-scale AIRmix saving system, shower hose PVC



kit barre de douche, barre 60 cm, douchette monojet anticalcaire avec système **AIRmix**, flexible PVC

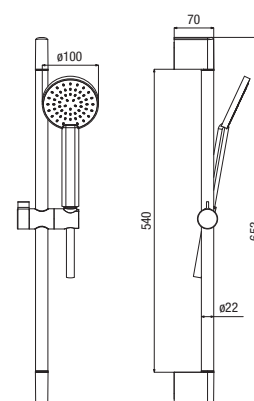



KI 040 CR

€ 55,00

kit saliscendi, asta 60 cm, doccia monogetto anticalcare con sistema **AIRmix** flessibile doccia PVC
slide rail kit, 60 cm tube, one spray handset anti-scale AIRmix saving system, shower hose PVC

kit barre de douche, barre 60 cm, douchette monojet anticalcaire avec système **AIRmix**, flexible PVC

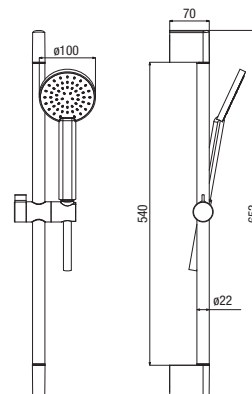

KI 076 CR

€ 72,00

kit saliscendi, asta 60 cm con portasapone doccia **cinque getti** anticalcare, flessibile doccia PVC
slide rail kit, 60 cm tube with soap dish five spray anti-scale handset, shower hose PVC

kit barre de douche, barre 60 cm avec porte savon douchette **cinq jets** anticalcaire, flexible PVC

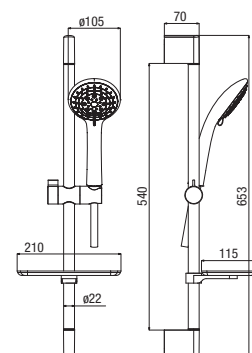

KI 064 CR

€ 63,00

kit saliscendi, asta 60 cm, doccia **tre getti** e flessibile doccia PVC
slide rail kit, 60 cm tube, three spray and handset, shower hose PVC

kit barre de douche, barre 60 cm, douchette **trois jets** et flexible PVC

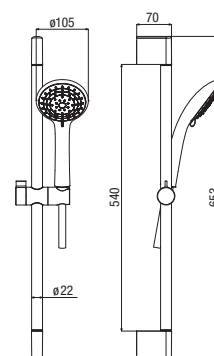

Idroterapia



KI 065 CR

€ 66,00

kit saliscendi, asta 60 cm, doccia **cinque getti**
 anticalcare, flessibile doccia PVC
slide rail kit, 60 cm tube, five spray
 anti-scale handset, shower hose PVC



kit barre de douche, barre 60 cm, douchette **cinq jets**
 anticalcaire, flexible PVC

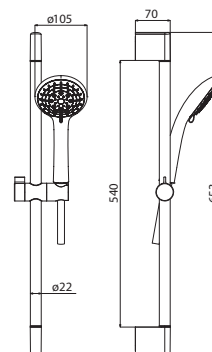

ø 130 mm

KI 075 CR

€ 133,00

kit saliscendi, asta 90 cm, doccia monogetto
 anticalcare, flessibile doccia PVC
slide rail kit, 90 cm tube, one-spray handset
 anti-scale, shower hose PVC



kit barre de douche, barre 90 cm, douchette monojet
 anticalcaire, flexible PVC

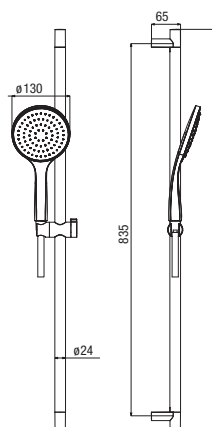

SL 118 CR

€ 94,00

asta saliscendi 110 cm, **ottone**
slide rail tube, 110 cm, brass
 barre de douche h 110 cm, **laiton**

KIT DOCCIA HANDSET KIT KIT DOUCHETTE

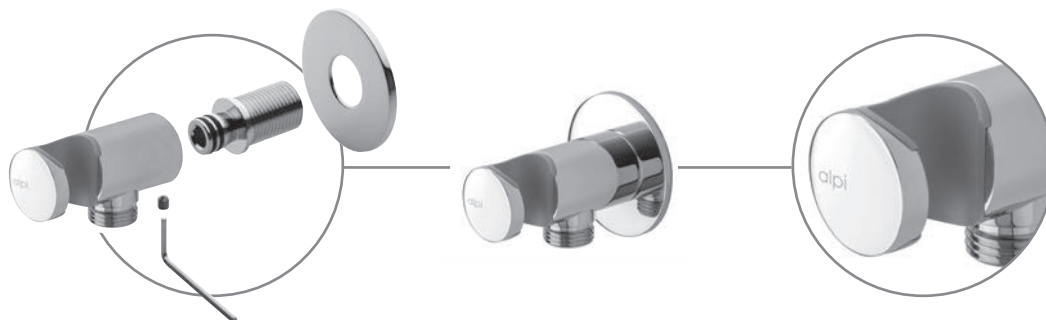

KI 091 CR

€ 100,00

kit doccia comprensivo di:
 - doccia monogetto anticalcare
 - supporto doccia con presa acqua
 - flessibile doccia PVC

handset kit including:
 - one spray handset anti-scale
 - shower bracket with water outlet
 - shower hose PVC

kit douchette comprenant:
 - douchette monojet anticalcaire
 - support douchette avec prise eau
 - flexible de douche PVC

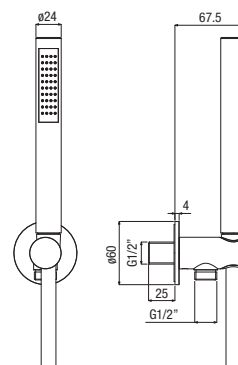

KI 092 CR

€ 124,00

kit doccia comprensivo di:
 - doccia monogetto anticalcare
 - supporto doccia con presa acqua
 - flessibile doccia PVC

handset kit including:
 - one spray handset anti-scale
 - shower bracket with water outlet
 - shower hose PVC

kit douchette comprenant:
 - douchette monojet anticalcaire
 - support douchette avec prise eau
 - flexible de douche PVC

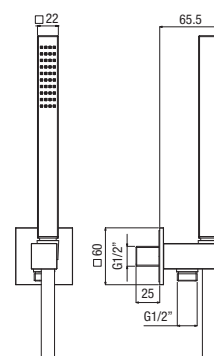

KI 046 CR

€ 90,00

kit doccia comprensivo di:
 - doccia monogetto anticalcare
 - supporto doccia con presa acqua
 - flessibile doccia PVC

handset kit including:
 - one spray handset anti-scale
 - shower bracket with water outlet
 - shower hose PVC

kit douchette comprenant:
 - douchette monojet anticalcaire
 - support douchette avec prise eau
 - flexible de douche PVC

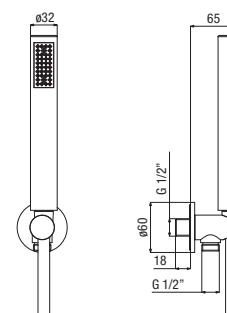

Idroterapia



KI 057 CR

€ 114,00

- kit doccia comprensivo di:
- doccia monogetto anticalcare
 - supporto doccia con presa acqua
 - flessibile doccia PVC

handset kit including:

- *one spray handset anti-scale*
- *shower bracket with water outlet*
- *shower hose PVC*

kit doccia comprendant:

- doccia monojet anticalcaire
- support douche avec prise eau
- flexible de douche PVC

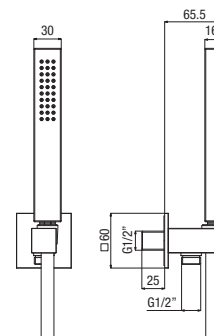

KI 094 CR

€ 101,00



- kit doccia comprensivo di:
- doccia **tre getti** anticalcare
 - supporto doccia, con presa acqua
 - flessibile doccia PVC

handset kit including:

- *three sprays anti-scale handset*
- *shower bracket with water outlet*
- *shower hose PVC*

kit doccia comprendant:

- doccia anticalcaire **trois jets**
- support douche avec prise eau
- flexible de douche PVC

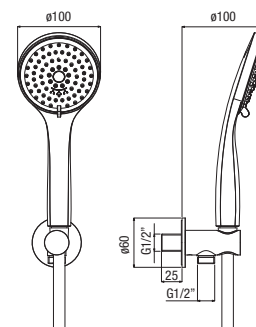

KI 060 CR

€ 99,00

- kit doccia comprensivo di:
- doccia monogetto anticalcare con sistema **AIRmix**
 - supporto doccia con presa acqua
 - flessibile doccia PVC

handset kit including:

- *one spray handset anti-scale with AIRmix saving system*
- *shower bracket with water outlet*
- *shower hose PVC*

kit doccia comprendant:

- doccia monojet anticalcaire avec système **AIRmix**
- support douche avec prise eau
- flexible de douche PVC

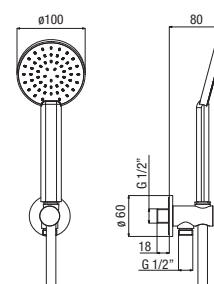

KI 078 CR

€ 39,00

- kit doccia comprensivo di:
- doccia monogetto anticalcare
 - supporto doccia
 - flessibile doccia PVC

handset kit including:

- *one spray handset anti-scale*
- *shower bracket*
- *shower hose PVC*

kit doccia comprendant:

- doccia monojet anticalcaire
- support douche
- flexible de douche PVC

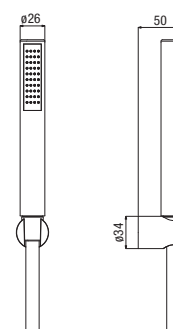



KI 054 CR

€ 44,00

kit doccia comprensivo di:
 - doccia monogetto anticalcare
 - supporto doccia
 - flessibile doccia PVC

handset kit including:
 - *one spray handset anti-scale*
 - *shower bracket*
 - *shower hose PVC*

kit douchette comprenant:
 - douchette monojet anticalcaire
 - support douchette
 - flexible de douche PVC

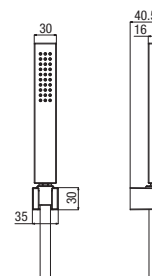

KI 051 CR

€ 49,00

kit doccia comprensivo di:
 - doccia monogetto anticalcare
 con sistema **AIRmix**
 - supporto doccia
 - flessibile doccia PVC

handset kit including:
 - *one spray handset anti-scale*
with AIRmix saving system
 - *shower bracket*
 - *shower hose PVC*

kit douchette comprenant:
 - douchette monojet anticalcaire
 avec système **AIRmix**
 - support douchette
 - flexible de douche PVC

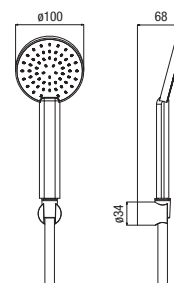

KI 056 CR

€ 41,00

kit doccia comprensivo di:
 - doccia monogetto anticalcare
 con sistema **AIRmix**
 - supporto doccia
 - flessibile doccia PVC

handset kit including:
 - *one spray handset anti-scale*
AIRmix saving system
 - *shower bracket*
 - *shower hose PVC*

kit douchette comprenant:
 - douchette monojet anticalcaire
 avec système **AIRmix**
 - support douchette
 - flexible de douche PVC

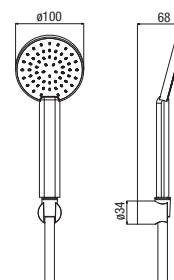

Idroterapia

DOCCE HANDSET DOUCHETTES



DC 065 CR

€ 28,00



doccia monogetto anticalcare ø 24 mm **METAL**
one spray handset anti-scale ø 24 mm METAL
 douchette monojet anticalcaire ø 24 mm **METAL**

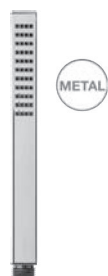
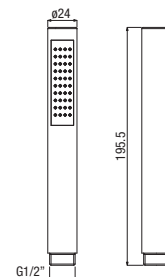

DC 066 CR

€ 32,00



doccia monogetto anticalcare **METAL**
one spray handset anti-scale METAL
 douchette monojet anticalcaire **METAL**

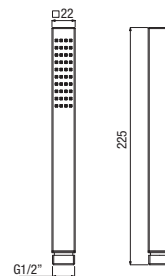

DC 063 CR

€ 29,00



doccia **tre getti** anticalcare ø 101 mm
ø 101 mm three sprays anti-scale handset
 douchette anticalcaire **trois jets** ø 101 mm

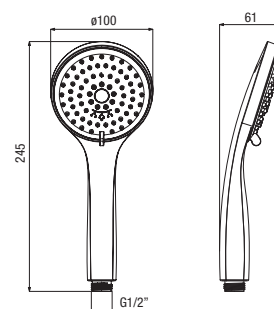

DC 064 CR

€ 52,00



doccia **tre getti** anticalcare ø 140 mm
ø 140 mm three sprays anti-scale handset
 douchette anticalcaire **trois jets** ø 140 mm

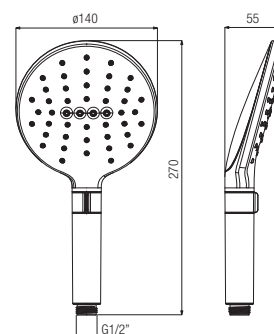



DC 061 CR

€ 37,00



doccia **tre getti** anticalcare a pulsante
three sprays anti-scale handset with press button
 douchette anticalcaire **trois jets**, sélection à bouton

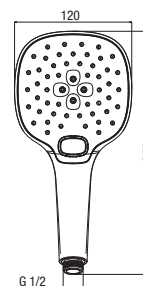

DC 060 CR

€ 32,00



doccia **tre getti** anticalcare a pulsante
three sprays anti-scale handset with press button
 douchette anticalcaire **trois jets**, sélection à bouton

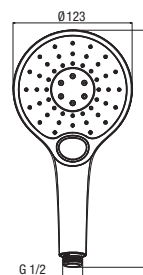

DC 056 CR

€ 32,00



doccia **cinque getti** anticalcare ø 105 mm
ø 105 mm five sprays anti-scale handset
 douchette **cinq jets** anticalcaire ø 105 mm

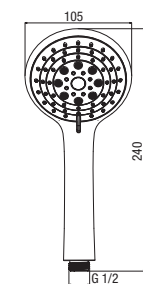

DC 055 CR

€ 30,00



doccia **tre getti** anticalcare ø 105 mm
ø 105 mm three sprays anti-scale handset
 douchette **trois jets** anticalcaire ø 105 mm

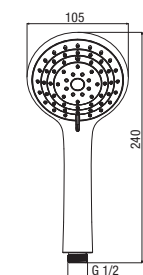

Idroterapia



ø 130 mm

DC 058 CR

€ 51,00



doccia monogetto anticalcare ø 130 mm
ø 130 mm one spray anti-scale handset
douchette monojet anticalcaire ø 130 mm

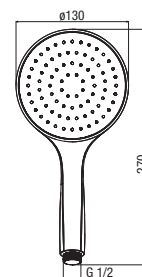

DC 051 CR

€ 26,00



doccia monogetto anticalcare ø 100 mm
con sistema **AIRmix**
ø 100 mm one-spray handset anti-scale
AIRmix saving system
douchette monojet anticalcaire ø 100 mm
avec système **AIRmix**

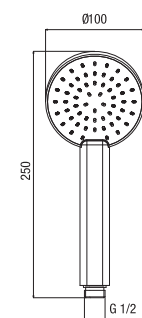

DC 057 CR

€ 15,00



doccia monogetto anticalcare ø 105 mm
ø 105 mm one spray anti-scale handset
douchette monojet anticalcaire ø 105 mm

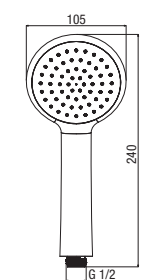

DC 042 CR

€ 14,00



doccia monogetto anticalcare ø 80 mm
ø 80mm one spray anti-scale handset
douchette monojet anticalcaire ø 80mm

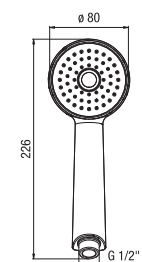



DC 054 CR € 22,00



doccia monogetto anticalcare
one spray anti-scale handset
 douchette monojet anticalcaire

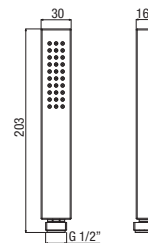

DC 027 CR € 17,00



doccia monogetto anticalcare ø 32 mm
ø 32 mm one spray anti-scale handset
 douchette monojet anticalcaire ø 32 mm

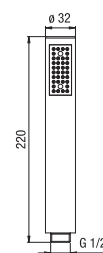

DC 059 CR € 39,00



doccia ergonomica anticalcare **tre getti**
three spray antiscala ergonomic handset
 douchette ergonomique anticalcaire **trois jets**

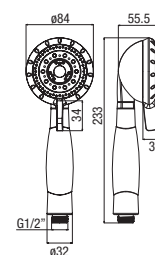
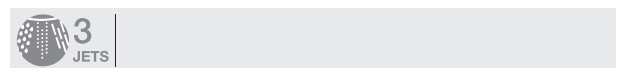

DC 049 CR € 13,00



doccia shut off
shut off handset
 douchette à main

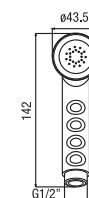

Idroterapia

BOCCHIE A MURO WALL MOUNTED SPOUTS BECS MURAL



AC 114 CR

€ 46,00

bocca a muro
wall spout
bec mural

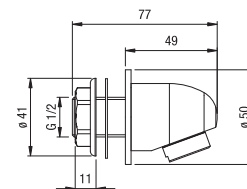

PRESE ACQUA E SUPPORTI DOCCIA WATER OUTLETS AND SHOWER BRACKETS PRISES D'EAU ET SUPPORT DOUCHETTE



AC 163 CR

€ 55,00

supporto doccia con presa acqua, **ottone**
shower bracket with water outlet, **brass**
support douchette avec prise eau, **laiton**

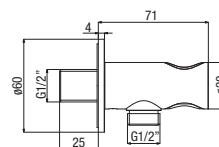

AC 171 CR

€ 75,00

supporto doccia con presa acqua, **ottone**
shower bracket with water outlet, **brass**
support douchette avec prise eau, **laiton**

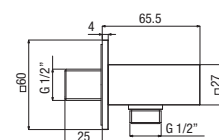

AC 172 CR

€ 38,00

presa acqua, **ottone**
water outlet, **brass**
prise eau, **laiton**

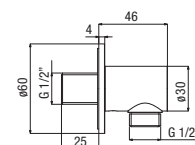



AC 132 CR

€ 49,00

presa acqua, **ottone**
 water outlet, **brass**
 prise eau, **laiton**

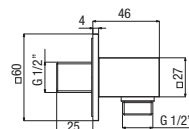

SM 016 CR

€ 6,00

supporto doccia, **ABS**
 shower bracket, **ABS**
 support douchette, **ABS**



SM 015 CR

€ 6,00

supporto doccia, **ABS**
 shower bracket, **ABS**
 support douchette, **ABS**



SM 017 CR

€ 7,50

supporto doccia orientabile, **ABS**
 adjustable shower bracket, **ABS**
 support douchette réglable, **ABS**

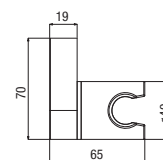

Idroterapia

FLESSIBILI DOCCIA SHOWER HOSES FLEXIBLES DE DOUCHE

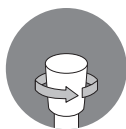

cono girevole
swivel nut
écrou tournant



igienico
hygienic
hygiénique



massima resistenza
maximum resistance
haute résistance



flessibile doccia PVC metallizzato 1/2"F x 1/2"F conico/conico
shower hose silver PVC 1/2"F x 1/2"F conical/conical nuts
flexible de douche PVC métallisé écrous conique/conique 1/2"Fx1/2"F



FL 126 CR 60 cm € 15,00



FL 120 CR 150 cm € 17,00



FL 128 CR 175 cm € 21,00



FL 123 CR 200 cm € 24,00

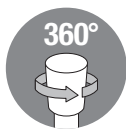

cono girevole
swivel nut
écrou tournant

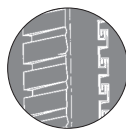

doppia aggraffatura
double interlock
double agrafage

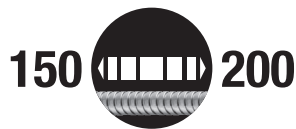

estensibile
extendable
extensible

FL 129 CR € 20,00

flessibile doccia doppia aggraffatura
150/200 cm 1/2"F x 1/2"F zigrinato/conico
shower hose, double interlock,
150/200 cm 1/2"F x 1/2"F knurled/conical nuts



flexible de douche double agrafage,
150/200 cm écrous moleté/conique 1/2"F x 1/2"F

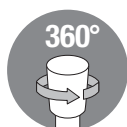

cono girevole
swivel nut
écrou tournant

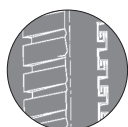

doppia aggraffatura
double interlock
double agrafage

FL 102 CR

€ 25,00

flessibile doccia **ottone** doppia aggraffatura
150 cm 1/2" F x 1/2" F zigrinato/conico

shower hose, double interlock, brass,
150 cm 1/2" F x 1/2" F knurled/conical nuts

flexible de douche double agrafage en laiton,
150 cm écrous moleté/conique 1/2" F x 1/2" F

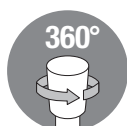

cono girevole
swivel nut
écrou tournant



doppia aggraffatura
double interlock
double agrafage

FL 108 CR

€ 35,00

flessibile doccia bordo vasca, **ottone**,
doppia aggraffatura, **200 cm** 1/2" F conico x 3/8" F

shower hose for deck bath, brass, double interlock,
200 cm, 1/2" F conical x 3/8" F

flexible de douche pour baignoire sur gorge,
laiton, double agrafage, **200 cm** 1/2" F conique x 3/8" F



Tender



Tender



temporizzati
timed flow control taps
 temporisés



TENDER di Alpi è la linea di rubinetti temporizzati **ideale in ogni ambiente ad alta frequenza e con uso continuo d'acqua.**

I rubinetti Tender razionalizzano i consumi e consentono un notevole risparmio d'acqua.

TENDER is Alpi timed flow control tap range, ideal for environments with high attendance and continuous water usage.

Tender taps rationalize consumption and allow for significant water saving.

TENDER est la ligne complète de robinets temporisés de Alpi, **idéale pour les environnements à haute fréquentation et de forte consommation d'eau.**

Les robinets temporisés Tender en permettent la rationalisation.

RUBINETTI LAVABO *BASIN TAPS* ROBINETS LAVABO

size **S**



TR 10LP CR

€ 56,00



rubinetto lavabo 1/2"
basin tap, 1/2"
 robinet lavabo 1/2"



VT 1100CR

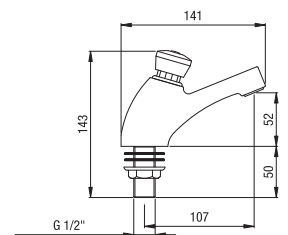

VT 1100CR

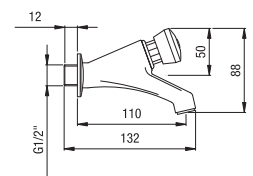

TR 20PP CR

€ 45,00



rubinetto lavabo a parete
wall mounted basin tap
 robinet lavabo mural

RUBINETTI DOCCIA SHOWER TAPS ROBINETS DE DOUCHE



TR 30DIP CR

€ 64,00

rubinetto doccia incasso
concealed shower tap
robinet de douche encastré



VT 1103CR

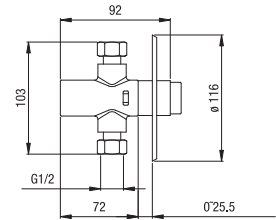

TR 30DEP CR

€ 72,00

rubinetto doccia esterno
exposed shower tap
robinet de douche apparent



VT 1100CR

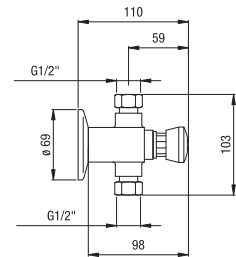

RUBINETTI ORINATOIO URINAL TAPS ROBINETS URINOIR



TR 25OP CR

€ 44,00

rubinetto orinatoio
urinal tap
robinet urinoir



VT 1100CR

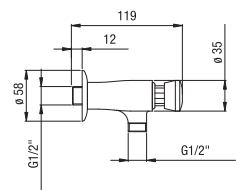

TR 25OPRC CR

€ 55,00

rubinetto orinatoio completo di raccordo
urinal tap with connection
robinet urinoir avec raccord



VT 1100CR

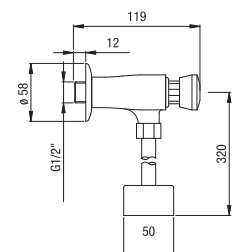



TR 40FPI CR

€ 84,00

flussometro incasso \varnothing 3/4"
concealed flushing valve \varnothing 3/4"
 fluxmètre encastré \varnothing 3/4"

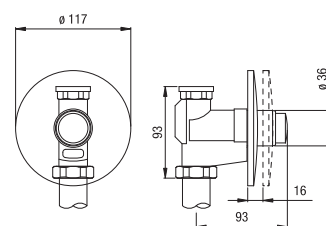

TR 40FPE CR

€ 84,00

flussometro esterno \varnothing 3/4"
exposed flushing valve \varnothing 3/4"
 fluxmètre apparent \varnothing 3/4"

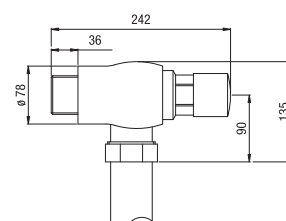

TR 40FPEP CR

€ 89,00

flussometro esterno inclinato \varnothing 3/4"
exposed inclined flushing valve \varnothing 3/4"
 fluxmètre incliné apparent \varnothing 3/4"

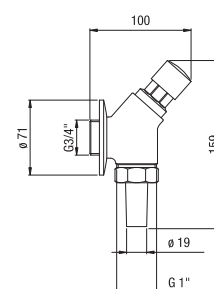



SF 113 CR

€ 49,00

soffione antivandalo attacco in **ottone**
anti-vandal shower head, brass connection
pomme de douche anti-vandal, raccord en **laiton**

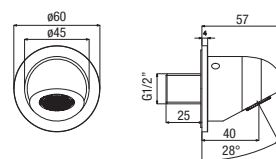

VT 1100 CR

€ 18,00

vitone temporizzato completo
complete headwork for non-concussive tap
tête céramique complète pour robinet temporisé

VT 1103 CR

€ 18,00

vitone temporizzato completo per TR30DIP
complete headwork for non-concussive tap TR30DIP
tête céramique complète pour TR30DIP



Accessori e ricambi

CARTUCCE MONOCOMANDO *SINGLE-LEVER*
 CARTRIDGES CARTOUCHES MONOCOMMANDE

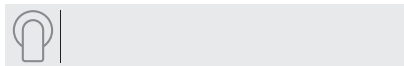

CR 005 € 24,00

cartuccia monocomando
 ø 35 mm con distributore
*ø 35 mm single-lever cartridge
 with distributor*
 cartouche pour monocommande
 ø 35 mm avec fond



CR 038 € 26,00

cartuccia monocomando ø 35 mm
 con distributore e limitatore di portata
*ø 35 mm single-lever cartridge
 with distributor, water-flow regulator*
 cartouche pour monocommande ø 35 mm
 avec fond, limiteur de débit

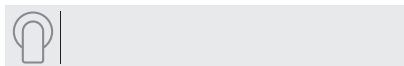

CR 023 € 24,00

cartuccia monocomando
 ø 35 mm senza distributore
*ø 35 mm single-lever cartridge
 without distributor*
 cartouche pour monocommande
 ø 35 mm sans fond



CR 039 € 26,00

cartuccia monocomando ø 35 mm
 senza distributore e limitatore di portata
*ø 35 mm single-lever cartridge
 without distributor, water-flow regulator*
 cartouche pour monocommande ø 35 mm
 sans fond, limiteur de débit

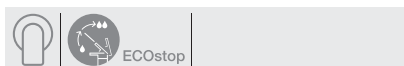

CR 034 € 26,00

cartuccia monocomando ø 35 mm
 con distributore e limitatore di portata
*ø 35 mm single-lever cartridge
 with distributor, water-flow regulator*
 cartouche pour monocommande ø 35 mm
 avec fond, limiteur de débit



CR 029 € 33,00

cartuccia monocomando ø 35 mm
 senza distributore, con limitatore di portata
 e sistema a risparmio energetico
*ø 35 mm single-lever cartridge
 without distributor, with water-flow
 and energy-saving system*
 cartouche pour monocommande
 ø 35 mm sans fond, avec limiteur de débit
 et économie d'énergie

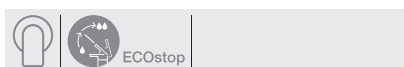

CR 035 € 26,00

cartuccia monocomando ø 35 mm
 senza distributore e limitatore di portata
*ø 35 mm single-lever cartridge
 without distributor, water-flow regulator*
 cartouche pour monocommande ø 35 mm
 sans fond, limiteur de débit



CR 030 € 33,00

cartuccia monocomando ø 35 mm
 con distributore, limitatore di portata
 e sistema a risparmio energetico
*ø 35 mm single-lever cartridge
 with distributor, water-flow and
 energy-saving system*
 cartouche pour monocommande
 ø 35 mm avec fond, limiteur de débit
 et économie d'énergie

**CARTUCCE TERMOSTATICHE THERMOSTATIC
CARTRIDGES CARTOUCHES THERMOSTATIQUES**



CR-101C

€ 66,00

cartuccia termostatica
thermostatic cartridge
cartouche thermostatique



CR 101/AC

€ 108,00



cartuccia termostatica
per acque invertite
*thermostatic cartridge
for water reversed pipes*
cartouche thermostatique
pour arrivées d'eau inversés

DEVIATORI DIVERTERS SELECTEURS



CR-107C

€ 66,00

cartuccia termostatica
thermostatic cartridge
cartouche thermostatique



CR 010NC

€ 30,00

cartuccia deviatrice **due uscite**
a dischi ceramici
two outlets ceramic diverter cartridge
cartouche sélecteur céramique
deux sorties

VITONI HEADWORKS TETES DE ROBINET



CR-150C

€ 54,00

cartuccia termostatica
thermostatic cartridge
cartouche thermostatique



VT 002

€ 14,00

vitone ceramico G1/2" 180°
ceramic headwork G1/2" 180°
tête céramique G1/2" 180°



CR-C3C

€ 66,00

cartuccia termostatica
thermostatic cartridge
cartouche thermostatique



VT 008SX

€ 14,00

vitone ceramico G1/2" 90°
ceramic headwork G1/2" 90°
tête céramique G1/2" 90°

Accessori e ricambi

ACCESSORI ACCESSORIES ACCESSOIRES



VT 1100 CR CR € 18,00

vitone temporizzato completo
complete headwork for non-concussive tap
tête complète
pour robinet temporisé

VT 1103 CR CR € 18,00

vitone temporizzato completo per TR30DIP
complete headwork for TR30DIP
tête complète pour TR30DIP



AC 229 € 117,00

kit prolunga incasso doccia monocomando
extension kit for concealed single-lever shower valve
kit d'extension pour mitigeur mécanique
douche encastré

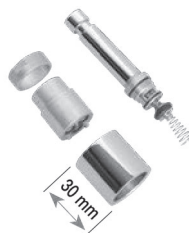

prodotti compatibili
compatible products
produits compatibles
**NA79863 - NU84863 - LO41863 -
UN18863 - SPS86863 - SPL72863 -
CPL87863 - JO74863**



AC 267 € 117,00

kit prolunga incasso lavabo monocomando
extension kit for concealed single-lever basin mixer
kit d'extension pour mitigeur mécanique
lavabo encastré

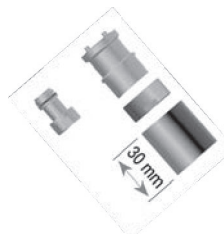

prodotti compatibili
compatible products
produits compatibles
**NU21876 - LO89876 - UN19876 -
SPL72876 - CPL87876**



AC 230 € 117,00

kit prolunga incasso doccia termostatico **due uscite**
extension kit for concealed two outlets thermostatic shower valve
kit d'extension pour thermostatique
douche encastré **deux sorties**

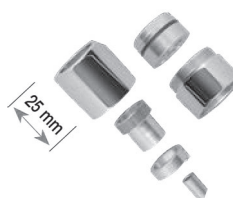

prodotti compatibili
compatible products
produits compatibles
**LO89163 - SA73163 - SO88163 -
UN57163 - BU85163 - SPS86163 -
SPL72163 - CPL87163**

Index

CODE	SERIE	PAG.
AC 114	IDROTERAPIA	124
AC 132	IDROTERAPIA	125
AC 163	IDROTERAPIA	124
AC 171	IDROTERAPIA	124
AC 172	IDROTERAPIA	124
AC 229	ACCESSORI E RICAMBI	136
AC 230	ACCESSORI E RICAMBI	136
AC 267	ACCESSORI E RICAMBI	136
BC 11151	JOY	56
BD 029	IDROTERAPIA	110
BD 034	IDROTERAPIA	110
BD 035	IDROTERAPIA	110
BD 036	IDROTERAPIA	111
BD 037	IDROTERAPIA	111
BD 038	IDROTERAPIA	111
BD 039	IDROTERAPIA	111
BD 040	IDROTERAPIA	110
BD 047	IDROTERAPIA	110
BD 048	IDROTERAPIA	110
CD 60RP108	COLONNE DOCCIA	90
CD 60RP708	COLONNE DOCCIA	90
CD 60SP109	COLONNE DOCCIA	91
CD 60SP709	COLONNE DOCCIA	91
CD 77RP110	COLONNE DOCCIA	89
CD 77SP111	COLONNE DOCCIA	89
CL 59176	SPORT SENIOR	63
CL 59201	SPORT SENIOR	63
CPL 87RM4151	CITY PLUS	41
CPL 87RM4151	COLONNE DOCCIA	95
CPL 87RP2151	CITY PLUS	38
CPL 87RP2151	COLONNE DOCCIA	83
CPL 87RP2251	CITY PLUS	37
CPL 87RP2251	COLONNE DOCCIA	79
CPL 87SP2151	CITY PLUS	38
CPL 87SP2151	COLONNE DOCCIA	83
CPL 87SP2251	CITY PLUS	37
CPL 87SP2251	COLONNE DOCCIA	79
CPL 87101	CITY PLUS	44
CPL 87106	CITY PLUS	44
CPL 87106/153	CITY PLUS	46
CPL 87106/160	CITY PLUS	46
CPL 87151	CITY PLUS	44
CPL 87155	CITY PLUS	43
CPL 87155/153	CITY PLUS	43
CPL 87155/160	CITY PLUS	43
CPL 87163	CITY PLUS	47
CPL 87176	CITY PLUS	34
CPL 87176/S	CITY PLUS	34
CPL 87201	CITY PLUS	35
CPL 87201/S	CITY PLUS	35
CPL 87250	CITY PLUS	36
CPL 87276	CITY PLUS	34
CPL 87276/S	CITY PLUS	34
CPL 87277/S	CITY PLUS	35
CPL 87282	CITY PLUS	36
CPL 87283	CITY PLUS	36
CPL 87301	CITY PLUS	35
CPL 87376	CITY PLUS	34
CPL 87382	CITY PLUS	36
CPL 87476	CITY PLUS	34

CODE	SERIE	PAG.
CPL 87801	CITY PLUS	42
CPL 87806	CITY PLUS	42
CPL 87808	CITY PLUS	43
CPL 87851	CITY PLUS	42
CPL 87855	CITY PLUS	42
CPL 87861	CITY PLUS	46
CPL 87863	CITY PLUS	46
CPL 87876	CITY PLUS	35
GR 005	ACCESSORI E RICAMBI	134
GR 010NC	ACCESSORI E RICAMBI	135
GR 023	ACCESSORI E RICAMBI	134
GR 029	ACCESSORI E RICAMBI	134
GR 030	ACCESSORI E RICAMBI	134
GR 034	ACCESSORI E RICAMBI	134
GR 035	ACCESSORI E RICAMBI	134
GR 038	ACCESSORI E RICAMBI	134
GR 039	ACCESSORI E RICAMBI	134
GR 101/AC	ACCESSORI E RICAMBI	135
GR-101C	ACCESSORI E RICAMBI	135
GR-107C	ACCESSORI E RICAMBI	135
GR-150C	ACCESSORI E RICAMBI	135
GR-C3C	ACCESSORI E RICAMBI	135
DC 027	IDROTERAPIA	123
DC 042	IDROTERAPIA	122
DC 049	IDROTERAPIA	123
DC 051	IDROTERAPIA	122
DC 054	IDROTERAPIA	123
DC 055	IDROTERAPIA	121
DC 056	IDROTERAPIA	121
DC 057	IDROTERAPIA	122
DC 058	IDROTERAPIA	122
DC 059	SPORT SENIOR	67
DC 059	CLINIC MR	75
DC 059	IDROTERAPIA	123
DC 060	IDROTERAPIA	121
DC 061	IDROTERAPIA	121
DC 063	IDROTERAPIA	120
DC 064	IDROTERAPIA	120
DC 065	IDROTERAPIA	120
DC 066	IDROTERAPIA	120
ECI 75RP2151	CITY PLUS	39
ECI 75RP2151	COLONNE DOCCIA	93
FL 102	IDROTERAPIA	127
FL 108	IDROTERAPIA	127
FL 120	IDROTERAPIA	126
FL 123	IDROTERAPIA	126
FL 126	IDROTERAPIA	126
FL 128	IDROTERAPIA	126
FL 129	IDROTERAPIA	126
JO 74RP3151	CITY PLUS	40
JO 74RP3151	COLONNE DOCCIA	94
JO 97RM2151	JOY	54
JO 97RM2151	COLONNE DOCCIA	84
JO 97RM2251	JOY	52
JO 97RM2251	COLONNE DOCCIA	80
JO 97RM7151	JOY	55
JO 97RM7151	COLONNE DOCCIA	86
JO 97RP2151	JOY	53
JO 97RP2151	COLONNE DOCCIA	85
JO 97RP2251	JOY	52

Index

CODE	SERIE	PAG.
JO 97RP2251	COLONNE DOCCIA	81
JO 97SM2151	JOY	54
JO 97SM2151	COLONNE DOCCIA	84
JO 97SM2251	JOY	53
JO 97SM2251	COLONNE DOCCIA	80
JO 97SM7151	JOY	55
JO 97SM7151	COLONNE DOCCIA	87
JO 74106	JOY	58
JO 74108	JOY	58
JO 74155	JOY	57
JO 74155/60	JOY	57
JO 74155/120	JOY	57
JO 74201	JOY	50
JO 74201/S	JOY	50
JO 74250	JOY	51
JO 74276	JOY	50
JO 74276/S	JOY	50
JO 74282	JOY	50
JO 74283	JOY	51
JO 74383	JOY	51
JO 74801	JOY	56
JO 74806	JOY	56
JO 74808	JOY	57
JO 74855	JOY	56
JO 74861	JOY	59
JO 74863	JOY	59
KI 040	IDROTERAPIA	115
KI 041	IDROTERAPIA	114
KI 044	IDROTERAPIA	114
KI 046	IDROTERAPIA	117
KI 051	IDROTERAPIA	119
KI 054	IDROTERAPIA	119
KI 056	IDROTERAPIA	119
KI 057	IDROTERAPIA	118
KI 060	IDROTERAPIA	118
KI 062	IDROTERAPIA	112
KI 063	IDROTERAPIA	112
KI 064	IDROTERAPIA	115
KI 065	IDROTERAPIA	116
KI 075	IDROTERAPIA	116
KI 076	IDROTERAPIA	115
KI 078	IDROTERAPIA	118
KI 080	IDROTERAPIA	113
KI 081	IDROTERAPIA	113
KI 082	IDROTERAPIA	111
KI 083	IDROTERAPIA	112
KI 086	IDROTERAPIA	113
KI 091	IDROTERAPIA	117
KI 092	IDROTERAPIA	117
KI 093	IDROTERAPIA	114
KI 094	IDROTERAPIA	118
MR 90RP2151	CLINIC MR	74
MR 90106	CLINIC MR	75
MR 90155	CLINIC MR	75
MR 90161	CLINIC MR	75
MR 90176	CLINIC MR	71
MR 90176/S	CLINIC MR	71
MR 90178	CLINIC MR	72
MR 90179	CLINIC MR	71
MR 90179/S	CLINIC MR	71

CODE	SERIE	PAG.
MR 90182	CLINIC MR	71
MR 90250	CLINIC MR	73
MR 90273	CLINIC MR	73
MR 90276	CLINIC MR	72
MR 90282	CLINIC MR	73
MR 90850	CLINIC MR	72
SF 060	IDROTERAPIA	108
SF 063	IDROTERAPIA	109
SF 064	IDROTERAPIA	108
SF 066A	IDROTERAPIA	106
SF 067A	IDROTERAPIA	106
SF 068A	IDROTERAPIA	107
SF 069A	IDROTERAPIA	106
SF 070A	IDROTERAPIA	107
SF 073A	IDROTERAPIA	104
SF 074A	IDROTERAPIA	105
SF 075A	IDROTERAPIA	104
SF 076A	IDROTERAPIA	105
SF 077	IDROTERAPIA	108
SF 083A	IDROTERAPIA	104
SF 084	IDROTERAPIA	109
SF 085	IDROTERAPIA	108
SF 101A	IDROTERAPIA	104
SF 102A	IDROTERAPIA	105
SF 113	IDROTERAPIA	110
SF 113	TENDER	133
SF 114A	IDROTERAPIA	105
SL 118	IDROTERAPIA	116
SM 015	IDROTERAPIA	125
SM 016	IDROTERAPIA	125
SM 017	IDROTERAPIA	125
SPL 72A861	SPORT PLUS	30
SPL 72A863	SPORT PLUS	30
SPL 72RP7151	SPORT PLUS	26
SPL 72RP7151	COLONNE DOCCIA	86
SPL 96RM2151	SPORT PLUS	25
SPL 96RM2151	COLONNE DOCCIA	82
SPL 96RM2251	SPORT PLUS	24
SPL 96RM2251	COLONNE DOCCIA	78
SPL 96RP7251	SPORT PLUS	25
SPL 96RP7251	COLONNE DOCCIA	81
SPL 96SM2151	SPORT PLUS	26
SPL 96SM2151	COLONNE DOCCIA	82
SPL 96SM2251	SPORT PLUS	24
SPL 96SM2251	COLONNE DOCCIA	78
SPL 72106	SPORT PLUS	29
SPL 72106/153	SPORT PLUS	29
SPL 72106/160	SPORT PLUS	29
SPL 72150	SPORT PLUS	23
SPL 72155	SPORT PLUS	28
SPL 72155/153	SPORT PLUS	29
SPL 72155/160	SPORT PLUS	29
SPL 72161	SPORT PLUS	30
SPL 72163	SPORT PLUS	31
SPL 72176	SPORT PLUS	20
SPL 72176/S	SPORT PLUS	20
SPL 72177/S	SPORT PLUS	21
SPL 72179	SPORT PLUS	20
SPL 72179/S	SPORT PLUS	20
SPL 72206	SPORT PLUS	29

CODE	SERIE	PAG.
SPL 72221	SPORT PLUS	21
SPL 72221/S	SPORT PLUS	21
SPL 72250	SPORT PLUS	22
SPL 72252	SPORT PLUS	23
SPL 72255	SPORT PLUS	28
SPL 72276	SPORT PLUS	20
SPL 72279	SPORT PLUS	20
SPL 72282	SPORT PLUS	22
SPL 72283	SPORT PLUS	22
SPL 72321	SPORT PLUS	21
SPL 72382	SPORT PLUS	22
SPL 72383	SPORT PLUS	22
SPL 72801	SPORT PLUS	27
SPL 72806	SPORT PLUS	27
SPL 72806/153	SPORT PLUS	28
SPL 72806/160	SPORT PLUS	28
SPL 72808	SPORT PLUS	28
SPL 72852	SPORT PLUS	23
SPL 72855	SPORT PLUS	27
SPL 72855/153	SPORT PLUS	27
SPL 72855/160	SPORT PLUS	27
SPL 72876	SPORT PLUS	21
SPS 86RM2151	SPORT SENIOR	64
SPS 86RM2151	COLONNE DOCCIA	85
SPS 86106	SPORT SENIOR	65
SPS 86155	SPORT SENIOR	65
SPS 86161	SPORT SENIOR	66
SPS 86163	SPORT SENIOR	67
SPS 86176	SPORT SENIOR	62
SPS 86176/S	SPORT SENIOR	62
SPS 86179	SPORT SENIOR	62
SPS 86179/S	SPORT SENIOR	62
SPS 86221	SPORT SENIOR	62
SPS 86221/S	SPORT SENIOR	62
SPS 86250	SPORT SENIOR	63
SPS 86282	SPORT SENIOR	63
SPS 86801	SPORT SENIOR	65
SPS 86806	SPORT SENIOR	65
SPS 86855	SPORT SENIOR	64
SPS 86861	SPORT SENIOR	66
SPS 86863	SPORT SENIOR	66
SWK 72A1863	SHOWER SET	98
SWK 87A1863	SHOWER SET	98
SWK 721163	SHOWER SET	101
SWK 741863	SHOWER SET	99
SWK 871163	SHOWER SET	100
SWK 872163	SHOWER SET	100
TA 54145	JOY	59
TR 10LP	TENDER	130
TR 20PP	TENDER	130
TR 250P	TENDER	131
TR 250PRC	TENDER	131
TR 30DEP	TENDER	131
TR 30DIP	TENDER	131
TR 40FPE	TENDER	132
TR 40FPEP	TENDER	132
TR 40FPI	TENDER	132
VT 002	ACCESSORI E RICAMBI	135
VT 008SX	ACCESSORI E RICAMBI	135
VT 1100	TENDER	133

CODE	SERIE	PAG.
VT 1100 CR	ACCESSORI E RICAMBI	136
VT 1103	TENDER	133
VT 1103 CR	ACCESSORI E RICAMBI	136

Condizioni generali di vendita Alpi

- 1 Gli ordini dovranno essere trasmessi dal rivenditore per iscritto, specificando i dati completi degli articoli, la quantità, gli sconti e altri dati significativi relativi a ciascun articolo. Alpi non sarà tenuta ad inviare alcuna conferma d'ordine, intendendosi, in tal caso, il contratto di compravendita concluso, ai sensi e per gli effetti dell'art. 1327, primo comma c.c., nel momento stesso dell'inizio dell'esecuzione dei singoli ordini da parte di ALPI, con esonero della stessa dall'onere di fornire prontamente avviso al rivenditore dell'iniziata esecuzione. Gli ordini non sono vincolanti per ALPI che ha la facoltà di accettarli o di rifiutarli a sua insindacabile discrezione. ALPI anche dopo la sua eventuale accettazione, comunque espressa, dell'ordine e in considerazione della non disponibilità dei prodotti o di cause di forza maggiore, si riserva il diritto di eseguire o meno gli ordini. In caso di mancata esecuzione dell'ordine accettato da ALPI, quest'ultima si impegna esclusivamente a dare tempestiva comunicazione al rivenditore il quale rinuncia a richiedere, fin da ora, eventuali penali e/o il risarcimento di eventuali danni.
- 2 I termini di consegna, se indicati, hanno un valore esclusivamente indicativo e mai tassativo (dipendendo l'approvvigionamento dei prodotti da fornire al rivenditore anche da fattori al di fuori del controllo della ALPI); ogni eventuale ritardo di ALPI non potrà mai costituire fonte di risarcimento del danno, né causa di risoluzione del contratto né potrà legittimare richieste di penali, di risoluzione del prezzo e/o di differimento dei pagamenti da parte del rivenditore.
- 3 L'individuazione delle merci nonché il trasferimento della proprietà avranno luogo nel momento in cui le merci saranno affidate al vettore.
- 4 Le spese di trasporto e di assicurazione nonché i rischi connessi al trasporto, sono a carico del rivenditore e la consegna (e la resa) dei prodotti avviene presso il magazzino di Gattico Veruno (EXW –Franco Fabbrica) salvo diverso accordo scritto tra le parti. Fermo quanto sopra la scelta dello spedizioniere e/o del vettore potrà essere effettuata anche da ALPI SPA. In ogni caso, ALPI non sarà responsabile per ritardi nella consegna, perdita e/o avaria delle merci che si verificassero durante il trasporto.
- 5 ALPI fornisce all'utente finale una "garanzia convenzionale" che si intende aggiuntiva e non sostitutiva di ogni altro diritto di cui gode il "consumatore" del prodotto nei confronti del soggetto dal quale ha acquistato il bene. In particolare, la garanzia convenzionale fornita da ALPI SPA lascia impregiudicati i diritti di cui il "consumatore" è titolare ai sensi del D.Lgs. 6 settembre 2005 n.206 e successive modificazioni ed integrazioni. Per "garanzia convenzionale" si intende esclusivamente la riparazione e/o sostituzione gratuita delle parti meccaniche dei prodotti venduti da ALPI, riconosciute viziata nella fabbricazione o nel materiale, nonché la riparazione e/o sostituzione delle parti dei prodotti venduti da ALPI che presentano gravi vizi della finitura superficiale esterna (es. cromatura) dovuti alla fabbricazione o al materiale, purché i summenzionati prodotti siano accompagnati da fattura o scontrino fiscale di acquisto. In ogni caso ALPI si riserva, a sua discrezione, il diritto di provvedere alla sostituzione del prodotto viziato con un prodotto analogo o di qualità superiore. La sostituzione e/o la riparazione dei prodotti e/o dei componenti viziati è subordinata alla spedizione a cura del rivenditore del prodotto e/o del componente viziato presso la sede della ALPI. Si precisa che la "garanzia convenzionale" riconosciuta da ALPI SPA non comprende tutti i costi di manodopera, dei materiali (ivi espressamente inclusi i rivestimenti di qualsiasi genere, a titolo esemplificativo e non esaustivo: piastrelle, pietre, metalli, legno, porcellane, tessuti, d'ora in poi, per brevità i rivestimenti), i costi di eventuali mobili e arredi, derivanti dalla necessità di disinstallare (e/o rendere accessibili per l'intervento), nonché di reinstallare i prodotti viziati (a titolo esemplificativo e non esaustivo per i prodotti integrati in mobili e/o pareti). La "garanzia convenzionale" riconosciuta da ALPI, pertanto, non comprende eventuali oneri, costi e/o danni causati ai rivestimenti, ai mobili e/o agli arredi dalla disinstallazione e dalla reinstallazione dei prodotti viziati. La durata della garanzia convenzionale riconosciuta da ALPI SPA è normalmente –se non diversamente e chiaramente indicato nel certificato di garanzia che accompagna ogni prodotto – di cinque anni dal momento dell'acquisto da parte dell'utilizzatore finale dei prodotti venduti da ALPI al rivenditore. La garanzia convenzionale interviene unicamente se i prodotti venduti da ALPI sono stati usati normalmente, in conformità al libretto di istruzioni e alle eventuali etichette di avvertimento e non si applica ai danni provocati da incuria, uso, installazione, manutenzione e/o pulizia errate o non conformi al citato libretto di istruzioni, danneggiamenti, deterioramento, da fulmini, fenomeni atmosferici, sovra tensioni e sovra correnti, insufficiente od irregolare alimentazione elettrica, e/o altre cause di forza maggiore, né per danni intervenuti durante il trasporto e/o per fatto del cliente e/o di terzi, né per danni dovuti alle contravvenzioni con le normative di sicurezza o tecniche richieste dal paese in cui il prodotto viene utilizzato. Inoltre, la garanzia convenzionale non si applica nei seguenti casi: 1) modifiche, manomissioni e/o utilizzo di accessori opzionali non originali forniti da terzi ed applicati ai prodotti; 2) utilizzo di ricambi non originali ALPI; 3) rotture e/o malfunzionamenti dovuti a gelo, impurità di ogni genere presenti nelle tubature, acque calcaree; 4) deterioramento delle finiture dovuto ad utilizzo di prodotti aggressivi, acidi e/o abrasivi; 5) malfunzionamenti caratterizzati da elevati valori di salinità e/o cloro dell'acqua; 6) mancato e/o inidoneo funzionamento dovuto a sabbia, detriti e/o impurità esistenti nell'acqua; 7) mancato uso di appropriati riduttori di pressione e filtri a monte dell'impianto; 8) pressioni o temperature non conformi ai parametri indicati nel libretto di istruzioni e/o nelle eventuali etichette di avvertimento che accompagnano i prodotti. Si precisa che la presente garanzia convenzionale non comprende la manutenzione ordinaria e la sostituzione di tutte le parti considerate "di consumo" e/o soggette a normale logorio e usura. Con la sottoscrizione per accettazione delle presenti Condizioni Generali di Vendita resta, invece, espressamente esclusa la garanzia legale per i vizi dei prodotti venduti da ALPI al rivenditore il quale, anche se riconosciuto responsabile nei confronti dell'utilizzatore finale per vizi dei sopracitati prodotti, non potrà agire in regresso verso ALPI. Pertanto, il rivenditore rinuncia ad avvalersi della garanzia legale e delle relative azioni nonché a rivalersi nei confronti di ALPI anche per i danni e/o spese eventualmente subiti.
- 6 I prezzi sono quelli risultanti dai cataloghi listini ALPI in vigore al momento della spedizione delle merci o, comunque, quelli normalmente praticati da ALPI. Sarà facoltà di ALPI modificare i prezzi indicati nei cataloghi listini con un preavviso di 15 giorni, e quindi senza influenza, nel caso di aumento o diminuzione, sugli ordini già accettati alla data di trasmissione della suddetta comunicazione di variazione, che saranno pertanto regolati dai prezzi non ancora variati.
- 7 I pagamenti dovranno essere fatti dal rivenditore in valuta euro. I termini e le modalità di pagamento sono quelli pattuiti tra ALPI e il rivenditore e sono da considerarsi inderogabili e essenziali nell'interesse di ALPI. In mancanza di pattuizioni dei termini e modalità di pagamento varranno quelli indicati nella fattura ALPI. In ogni caso la ALPI ha la facoltà di chiedere l'esecuzione del contratto senza l'onere di comunicazione di cui all'art.1457 c.c.. ALPI si riserva la facoltà di modificare e comunicare per iscritto diversi termini di pagamento e/o modalità di pagamento applicabili: in tal caso, i nuovi termini e/o modalità di pagamento si riterranno accettati dal rivenditore qualora questo non comunichi per iscritto a ALPI la mancata accettazione degli uni e/o delle altre entro e non oltre 15 (quindici) giorni dal ricevimento della correlativa informazione di variazione da parte di ALPI.
- 8 Il mancato e/o ritardato pagamento rispetto ai termini indicati nell'origine del rivenditore accettato dalla ALPI o, in mancanza, nella fattura ALPI comporterà l'applicazione di un interesse di mora determinato ai sensi dell'art. 5 D.Lgs.231/2002 e successive modificazioni ed integrazioni. Inoltre, in caso di mancato e/o ritardato pagamento rispetto ai termini previsti, ALPI potrà sospendere, a sua insindacabile discrezione, sino all'integrale pagamento del dovuto, tutti o alcuni degli ordini trasmessi dal rivenditore e eventuali servizi forniti al medesimo e modificare i termini e/o le modalità di pagamento con effetto immediato previa semplice comunicazione scritta. Decorsi 15 giorni dal mancato e/o ritardato pagamento, ALPI potrà annullare totalmente o parzialmente, a sua insindacabile discrezione, gli ordini non ancora evasi anche se già accettati.
- 9 Il pagamento del prezzo delle merci deve essere effettuato presso il domicilio della ALPI in Gattico Veruno (NO), Via Geola n.9; gli eventuali pagamenti fatti in luoghi diversi dal domicilio sopraindicato della ALPI, anche se accettati da quest'ultima, avranno unicamente valore di mera tolleranza e non potranno mai costituire modifica del principio del pagamento al domicilio indicato.
- 10 Il pagamento effettuato per mezzo di assegni circolari e/o bancari, anche se tale modalità risultasse accettata dalla ALPI, avviene ad esclusivo rischio del rivenditore nel senso che quest'ultimo non è liberato dalla sua obbligazione di pagamento se non prova l'avvenuto effettivo incasso da parte della ALPI. Fermo restando quando sopra, resta altresì inteso che in caso di furto e/o smarrimento di assegni inviati dal rivenditore, anche se avvenuti dopo che siano pervenuti alla ALPI e/o ai suoi incaricati e/o agenti, la ALPI è già fin d'ora espressamente esentata sia da qualunque responsabilità al riguardo, sia dal doversi attivare per chiedere duplicati degli assegni e/o l'ammortamento degli stessi.
- 11 Le illustrazioni e le informazioni contenute nei depliant, nei cataloghi listini, nel sito web di ALPI, nelle schede descrittive dei prodotti ALPI e in qualsiasi altro materiale informativo e/o pubblicitario, attraverso qualsiasi mezzo comunicato, pur rappresentando i singoli articoli, non costituiscono impegno di fedele esecuzione a carico di ALPI. Conseguentemente, i pesi e le misure in essi previsti sono da ritenersi esclusivamente indicativi e, pertanto, ALPI non si assume responsabilità in merito. ALPI si riserva, comunque, il diritto di apportare ai prodotti commercializzati in qualsiasi momento tutte le modifiche che ritiene indispensabili al fine di ottimizzare la produzione indipendentemente da quanto sia rappresentato e descritto nei depliant, nel catalogo-listino, nelle schede descrittive dei prodotti, nel sito web di ALPI e comunque in qualsiasi materiale atto alla promozione e alla vendita dei prodotti. Non sono ritenute, altresì, impegnative per ALPI le dichiarazioni, le promesse, le condizioni e le garanzie provenienti da dipendenti, rappresentanti, agenti e procacciatori, che differiscono dalle condizioni di vendita qui riprodotte, ed in ogni caso tutte quelle non incluse in atti sottoscritti dai legali rappresentanti di ALPI.

- 12 Si stabilisce di comune accordo che per la risoluzione di ogni eventuale controversia relativa all'interpretazione, esecuzione e risoluzione delle presenti Condizioni Generali di Vendita o relativa ai rapporti di compravendita che intercorreranno tra le parti o, comunque, relativa a qualsiasi questione collegata e/o connessa ai medesimi, sarà competente in via esclusiva il Foro di Milano dell'Autorità giudiziaria italiana.
- 13 Il rivenditore non potrà proporre domande, azioni, né sollevare eccezioni nei confronti della ALPI, se non dopo avere provveduto al pagamento di tutto quanto dovuto alla stessa per capitale, interessi e spese in relazione alle forniture di merci. Inoltre, si pattuisce che il rivenditore non potrà compensare propri eventuali crediti con le somme dovute a ALPI per l'acquisto della merce.
- 14 I prezzi eventualmente indicati nei cataloghi e nei listini si intendono esclusivamente consigliati al pubblico, espressi in euro, e non sono comprensivi di IVA.
- 15 La legge applicabile è esclusivamente la Legge Italiana, con espressa esclusione delle altre leggi nazionali e/o alle convenzioni internazionali sulla vendita internazionale di merci.
- 16 Le condizioni, i termini e le modalità di pagamento, nonché gli sconti finanziari e/o commerciali, nonché i contributi e/o premi eventualmente previsti, saranno comunque sempre subordinati alla circostanza che il pagamento delle forniture venga effettuato dal rivenditore nel rispetto dei termini previsti.
- 17 Saranno a carico del rivenditore il pagamento di tutte le imposte, tasse, dazi, oneri fiscali e/o amministrativi, nonché i costi e le spese di ogni genere previste da enti statali, governativi e/o amministrativi relativamente all'acquisto, all'importazione, all'esportazione e alla rivendita dei prodotti acquistati da ALPI SPA.
- 18 Le presenti condizioni generali di vendita non costituiscono per il rivenditore un obbligo di acquisto, né per ALPI SPA un obbligo di vendita. Pertanto, non intercorrerà tra le parti alcun obbligo di fornitura, né alcuna forma di esclusiva verrà conferita, essendo il rapporto contrattuale che intercorrerà tra le parti di semplice compravendita.
- 19 L'eventuale tolleranza di violazioni e/o comportamenti in contrasto con le presenti Condizioni Generali di Vendita non potrà considerarsi come rinuncia a quanto con le medesime espressamente previsto né potrà inficiare la validità delle clausole disattese. Nel caso di nullità di una o più delle presenti clausole o di parti di esse, per contrasto con norme imperative di legge, tali disposizioni si intenderanno di diritto sostituite, nei soli limiti del contrasto da quanto legislativamente previsto.
- 20 Fatto salvo il caso di dolo o colpa grave di ALPI SPA, la responsabilità e il conseguente ammontare del risarcimento eventualmente dovuto da ALPI nei confronti del rivenditore sono limitati al prezzo di acquisto da parte del rivenditore del prodotto e dei prodotti ALPI oggetto di contestazione e/o di inadempimento.
- 21 Condizioni contrattuali differenti dalle presenti Condizioni generali di vendita ALPI anche se richiamate, aggiunte, modificate e/o inserite negli ordini o in qualsiasi comunicazione del rivenditore, non avranno valore se non espressamente e specificatamente accettate per iscritto da un legale rappresentante di ALPI SPA.
- 22 Il testo in lingua italiana del presente contratto è l'unico facente fede come testo originale.
- 23 Il rivenditore riconosce che ditta e marchio usato da ALPI sono di esclusiva proprietà della medesima. Il rivenditore non potrà reclamare diritti o proprietà relativi alla ditta o al marchio di cui sopra. Ciò né direttamente né indirettamente, per interposta persona, società e/o ente. L'utilizzo del marchio ALPI da parte del rivenditore, laddove consentito, avverrà in conformità alle direttive stabilite da ALPI. In caso di apposizione del marchio ALPI sull'insegna del rivenditore, oltre ad essere preventivamente autorizzato per iscritto da ALPI, sarà tenuto esclusivamente il rivenditore al pagamento di qualsiasi imposta e/o tassa di legge, comprese quelle inerenti la pubblicità. E' fatto salvo il caso in cui il marchio compaia sul materiale promozionale eventualmente fornito da ALPI al rivenditore: in tali casi il rivenditore non necessiterà di alcuna autorizzazione di ALPI. In ogni caso, il rivenditore si asterrà dal promettere o rappresentare a qualsiasi soggetto, verbalmente o per iscritto, prestazioni diverse da quelle previste dai cataloghi, pieghevoli, schede descrittive dei prodotti, manuali di istruzione e, in genere, dal materiale pubblicitario o illustrativo fornito da ALPI. Il rivenditore è tenuto ad accertarsi che ogni forma di pubblicità, dallo stesso eventualmente realizzata, nella quale compaiono i prodotti ALPI, sia conforme alla normativa vigente di legge in materia pubblicitaria.
- 24 Tutti i dati personali ricevuti in forza dei rapporti contrattuali regolamentati dalle presenti Condizioni Generali di Vendita verranno trattati in forma telematica e cartacea. La comunicazione dei dati potrà essere effettuata da ALPI, per quanto di loro rispettiva e specifica competenza, a consulenti fiscali, a società di revisione contabile, a professionisti, ad enti pubblici, ad istituti di credito, ad agenti di commercio, promoters, merchandisers, centri di assistenza tecnica, rispetto ai quali vi sia per ALPI l'obbligo, o la necessità, o l'opportunità di comunicazione, e ciò anche al fine del più corretto adempimento di ogni rispettivo obbligo contrattuale.
- 25 Il rivenditore non potrà cedere, neppure parzialmente, senza il preventivo consenso scritto di ALPI, diritti ed obblighi previsti dalle presenti Condizioni Generali di Vendita, né eventuali crediti vantati nei confronti di ALPI SPA.
- 26 Il rivenditore si impegna a mantenere riservate tutte le informazioni di qualsiasi natura ed in ogni modo acquisite durante lo svolgimento delle prestazioni regolamentate dalle presenti Condizioni Generali di Vendita. In particolare, il rivenditore si impegna a non comunicare a terzi tutte le informazioni acquisite durante lo svolgimento delle prestazioni regolamentate dalle Condizioni Generali di Vendita, ed a mettere in atto tutte le precauzioni affinché anche i propri dipendenti e/o collaboratori osservino tale disposizioni, il tutto anche nel pieno rispetto di quanto disposto del D.Lgs. n.196/2003. A tal fine si stabilisce che: tutte le informazioni in qualunque modo acquisite e/o raccolte dal rivenditore non verranno utilizzate, né diffuse o comunicate a terzi, per scopi diversi da quelli contemplati dalle presenti Condizioni Generali di Vendita, salvo tuttavia il caso in cui si debba ottemperare a obblighi regolamentari o di legge o a richieste di Autorità italiane o estere alle quali non si possa opporre rifiuto, oppure tali informazioni siano già di dominio pubblico o siano divenute di dominio pubblico per cause diverse dalla violazione degli obblighi di riservatezza pattuiti con le presenti Condizioni Generali di Vendita. Il rivenditore si impegna a comunicare e a far osservare gli obblighi di riservatezza di cui al presente impegno ai propri dipendenti e a tutti coloro i quali, per qualsivoglia motivo, collaborino o abbiano collaborato all'esecuzione delle prestazioni oggetto delle presenti Condizioni Generali di Vendita. Le previsioni e i divieti di cui al presente articolo rimarranno in vigore anche dopo l'eventuale risoluzione, recesso o cessazione per qualsiasi altro motivo dei rapporti contrattuali che dovessero intercorrere tra ALPI e il rivenditore.
- 27 Pur essendo redatte le presenti "Condizioni generali di vendita" anche in inglese e francese, in caso di discordanza tra il testo italiano e quello redatto in altra lingua, prevarrà quanto indicato nel testo italiano, da ritenersi, pertanto, come l'unico facente fede come testo originale.

Alpi general conditions of sale

- 1 Orders shall be sent by the dealer in writing, specifying full details of the items, quantity, discounts and any other important data relating to each article. Alpi shall not be required to send an order confirmation whereby, in this case, the contract of sale is intended as concluded, in accordance with Article 1327, first paragraph of the Italian Civil Code, at the time when execution of each order by Alpi begins, relieving Alpi of its obligation to promptly give notice of the beginning of performance to the dealer. Orders shall not be binding for Alpi which has the right to accept or reject them, at its sole discretion. Alpi, even after acceptance, however expressed, of an order, and in consideration of the fact that products may be unavailable or due to force majeure events, reserves the right to decide whether or not to execute the order. If an order accepted by Alpi is not executed, Alpi undertakes to only give prompt notice thereof to the dealer who hereby agrees to refrain from requesting any penalty and/or compensation for any damage.
- 2 The terms of delivery, if indicated, are merely indicative and not binding (is this depends on the procurement of products to supply to the dealer and also depends on factors beyond Alpi's control); any delays by Alpi shall in no way constitute grounds for compensation for damage, or termination of the agreement, or grounds to request penalties, price reductions and/or deferred payment by the dealer.
- 3 The identification of goods and transfer of ownership shall take place when the goods are entrusted to the carrier.
- 4 The dealer shall be responsible for all costs for transport and insurance as well as the transport-related risks, and the delivery (and return) of products shall be at Alpi's warehouse in Gattico Veruno (EXW – Ex Works), unless the parties agree otherwise in writing. Notwithstanding the foregoing, Alpi S.p.A. shall also be entitled to choose the forwarding agent and/or carrier. In any case, Alpi shall not be responsible for delays in delivery, loss and/or damage to goods incurred during transport.
- 5 Alpi provides the end user with a "standard warranty" which is intended to supplement and not replace any other rights enjoyed by the "consumer" of the product against the party from whom they bought the item. In particular, the standard warranty provided by Alpi S.p.A. shall be without prejudice to the consumer rights provided for in Legislative Decree no. 206 of 6 September 2005 as subsequently amended and supplemented. The "standard warranty" sold by Alpi, acknowledged to be defective in materials or workmanship, as well as the repair and/or replacement of parts of products sold by Alpi which present serious defects in the outer surface finish (e.g. chromium plating) due to workmanship or material, provided that the above mentioned products are accompanied by the relevant invoice or receipt (proof of purchase). In any case, Alpi reserves the right, as its discretion, to substitute the defective product with a similar product or one of higher quality. Replacement and/or repair of products and/or defective components are subject to the dealer shipping the defective product and/or component to the premises of Alpi. The "standard warranty", recognised by Alpi, does not include costs for labour, materials (expressly including coverings of any nature, including, but not limited to: tile, stone, metal, wood, porcelain, textiles, hereby referred to as Coverings for the sake of brevity), the costs for any furniture and furnishings, resulting from the need to uninstall (and/or make accessible for the work), as well as to reinstall defective products (including, but not limited to products incorporated into furniture and/or walls). Therefore, Alpi's "standard warranty" does not cover any charges, costs and/or damage caused by coverings, to furniture and/or furnishings due to installing and reinstalling defective products. Alpi S.p.A.'s standard warranty is typically – unless otherwise clearly indicated on the warranty certificate that comes with each product – valid for a period of five years from the date of purchase by the end users of products sold by Alpi to a dealer. The standard warranty will be valid only if the products sold by Alpi have been used normally, in accordance with the instruction booklet and any warning labels and does not apply to damage caused by negligence, misuse, incorrect installation, maintenance and/or cleaning, failure to comply with the instructions, damages, deterioration caused by lightening, weather, overcurrent and overvoltage, insufficient or irregular power supply, and/or for reasons attributable to the customer and/or third parties, or damage due to noncompliance with the safety and technical regulations of the country where the product is used. Furthermore, the standard warranty does not apply in the following cases: 1) modifications, tampering and/or use of non-original optional accessories supplied by third parties and applied to the products; 2) use of non-original spare parts; 3) breakage and/or malfunctions due to frost, impurities of any nature in pipework, hard water; 4) deterioration of the finish due to harsh, acidic and/or chloride in the water; 6) failure or improper functioning due to sand, debris and/or impurities in the water; 7) failure to use appropriate pressure reduction units and filters upstream of the system; 8) pressures or temperatures which do not comply with the parameters indicated in the instruction booklet and/or any warning labels accompanying the products. Please note that this standard warranty does not cover routine maintenance or the replacement of all parts considered "consumable" and/or subject to normal wear and tear. In signing these General Conditions of Sale for acceptance, it remains understood that the legal guarantees are expressly excluded for defects in products sold by Alpi to the dealer who, even if held liable towards the end user for defects in the abovementioned products, shall not be entitled to take legal recourse against Alpi. Therefore, the dealer waives the right to make use of the legal guarantee and related actions as well as to take action against Alpi, also for any damage suffered and/or expenses incurred.
- 6 The prices are indicated in Alpi price lists in force at the time goods are shipped, or in any case those normally charged by Alpi. Alpi shall be entitled to change the prices indicated in the price lists with 15-day notice, and this shall therefore not affect orders already accepted on the sending date of the notification of price changes, should there be an increase or decrease, which shall therefore be governed by the prices not yet changed.
- 7 Payments shall be made by the dealer in euro. The terms and conditions of payment shall be those agreed between Alpi and the dealer and shall be deemed mandatory and essentials in the interest of Alpi. In the absence of agreements regarding the terms and conditions of payment, those indicated in the Alpi invoice shall apply. In any case, Alpi has the right to request the execution of the contract with no obligation to provide notice as per art. 1457 of the Italian Civil Code. Alpi reserves the right to change and communicate in writing different applicable payment terms and/or payment methods: in this case, the new payment terms and/or methods shall be deemed accepted by the dealer if he/she fails to notify Alpi in writing of his/her non-acceptance of the payment terms and/or methods no later than 15 (fifteen) days from receipt of the notice of change by Alpi.
- 8 Non-payment and/or late payment with respect to the terms specified in the dealer's order accepted by Alpi or, failing which, in the Alpi invoice shall result in the application of default interest calculated in accordance with Article 5 of Legislative Decree 231/2002 as subsequently amended and supplemented. Furthermore, in case of non-payment and/or late payment with respect to the deadlines, Alpi may suspend, at its sole discretion, until full payment of the amount due, all or some of the orders sent by the dealer along with any services provided to the dealer and change the terms and/or methods of payment with immediate effect by simple written communication. After 15 days have passed from non-payment and/or late payment, Alpi may cancel, in full or in part, as its sole discretion, any orders which have not been processed, even if already accepted.
- 9 The payment of goods shall be made at Alpi's place of business located on Via Geola no. 9 in Gattico Veruno (NO); any payments made in places other than the abovementioned place of business indicated by Alpi, even if accepted by the latter, shall merely be tolerated and shall not change the principle of payment to the place of business indicated.
- 10 Payment made by bank drafts and/or cheques, even if accepted by Alpi is at its sole risk of the dealer in the sense that the latter is not discharged from its obligation to pay unless it can prove actual collection by Alpi. Notwithstanding the foregoing, it is also understood that in case of theft and/or loss of cheques sent by the dealer, even after they have been received by Alpi and/or its representatives and/or agents, Alpi is hereby expressly exempted from any responsibility in this regard, both from having to request duplicates of the cheques and/or stop payment on them.
- 11 The illustrations and information contained in brochures, catalogues, price lists, Alpi website, Alpi products description sheets and any other information and/or advertising materials, communicated through any means, even if they represent the individual products, are for illustration purposes only and are not binding on Alpi. As a result thereof, any weights or dimensions included therein are intended as a rough guide only, thus Alpi assumes no responsibility in this regard. However, Alpi reserves the right to make changes to the products marketed at any time it deems necessary in order to optimise production, regardless of how it is represented and described in brochures, catalogue price lists, product description sheets, the Alpi website and any other materials used to promote and sell products. Declarations, promises, conditions and guarantees made by employees, representatives, agents and promoters, which differ from the conditions of sale reproduced herein, and in any case, anything not included in the acts signed by Alpi legal representatives are not considered binding for Alpi.
- 12 It is hereby established, by common agreement, that the Court of Milan of the Italian Judicial Authority shall have sole jurisdiction to settle any disputes related to the interpretation, performance and termination of these General Conditions of Sale or related to the buyer-seller relationships between the parties or, in any case, related to any issue linked and/or connected thereto.
- 13 The dealer may not present claims, actions, or raise objections against Alpi if not after paying all amounts due to Alpi for capital, interests and expenses related to the supply of goods. In addition, it is agreed that the dealer may not set off any of its claims with amounts due to Alpi for the purchase of goods.

- 14 Prices that may be indicated in the catalogues and price lists are only recommended to the public, expressed in euro, and do not include the VAT.
- 15 This agreement shall not be governed by the Laws of Italy, with express exclusion of other national laws and/or International conventions on the international sale of goods.
- 16 The terms and conditions of payment, including financial and/or trade discounts, as well as any other contributions and/or awards that may be provided, shall always be conditional on the requirement that the dealer pays for supplies in compliance with the terms indicated.
- 17 The dealer shall be responsible for paying all taxes, duties, tax and/or administrative burdens, as well as any other costs and expenses of any kind imposed by state, government and/or administrative bodies related to the purchase, import, export and sale of products purchased from Alpi.
- 18 These General Conditions of Sale do not constitute any obligation of the dealer to purchase, or any obligation of Alpi to sell. Therefore, there are no supply obligations between the parties, nor any form of exclusive rights shall be granted, as the contractual relations between the parties are limited to merely buying and selling.
- 19 Any tolerance of breach and/or conduct in conflict with these General Conditions of Sale shall not be considered a waiver of the same nor shall it affect the validity of the clauses disregarded. In case of invalidity of one or more of these provisions or parts thereof, due to conflict with mandatory provisions of law, those provisions shall be automatically replaced, only to the extent of the conflict as contemplated by law.
- 20 Except in cases of wilful misconduct or gross negligence by Alpi, the liability of and resulting amount of compensation due from Alpi to the dealer shall be limited to the purchase price by the dealer of the Alpi product or products which are subject matter of the dispute and/or breach.
- 21 Any contractual conditions that differ from Alpi's General Conditions of Sale, including those referred to, added, changed and/or included in the orders or any communication by the dealer, shall not be valid unless they are expressly and specifically accepted in writing by a legal representative of Alpi S.p.A.
- 22 The dealer acknowledges that the company name and trademarks used by Alpi are the exclusive property of Alpi. The dealer may not claim rights or ownership to the company name or trademarks referred to above, whether directly or indirectly, or through intermediaries, companies and/or entities. Use of Alpi trademark by the dealer, where permitted, shall take place in accordance with the guidelines established by Alpi. In case Alpi trademark is applied to the dealer's sign, in addition to requiring prior written permission from Alpi, the dealer shall be solely responsible for paying any duties and/or taxes required by law, including those related to advertising. It is without prejudice to the case where trademark appears on any promotional material provided by Alpi to the dealer: in such cases the dealer shall not require permission by Alpi. In any case, the dealer shall refrain from promising or representing to any person, whether verbally or in writing, any services other than those provided in the catalogues, leaflets, product description sheets, instruction manuals and, in general, advertising material or information provided by Alpi. The dealer shall be required to ensure that all forms of advertising created by the dealer in which Alpi products appear comply with the regulations of law of advertising.
- 23 All personal data received under the contractual relationships governed by these General Conditions of Sale shall be processed electronically and on paper. Data communication can be performed by Alpi, to the best of their respective and specific expertise, to tax consultants, audit firms, professionals, public institutions, banks, sales agents, promoters, merchandisers, technical service centres, for which Alpi is obliged, or required or has the opportunity to communicate, also in order to properly fulfil each respective contractual obligation.
- 24 The dealer may not assign, even partially, without the prior written consent of Alpi, the rights and obligations under these General Conditions of Sale, nor any amounts receivables from Alpi S.p.A.
- 25 The dealer agrees to keep confidential all information of any nature and in any case acquired during the performance of the services governed by these General Conditions of Sale. In particular, the dealer agrees not to disclose to third parties any information obtained during the performance of the services governed by these General Conditions of Sale, and to take all necessary steps to ensure that its employees and/or collaborators comply with these provisions, also in full compliance with the provisions of Legislative Decree no. 196/2003. To this end, it is hereby established that: all information in any manner obtained and/or collected by the dealer shall not be used, disclosed or communicated to third parties, for purposes other than those set out in these General Conditions of Sale, except, however, in the case where (i) the dealer is required to comply with regulatory or legal obligations or is requested by Italian or foreign authorities for which the dealer cannot refuse, or (ii) the information is already in the public domain or has entered the public domain for reasons other than breach of the confidentiality obligations agreed under these General Conditions of Sale. The provisions and prohibitions referred to in this clause shall remain in effect even after any termination, withdrawal or discontinuance for any reason whatsoever of the contractual relationships between Alpi and the dealer.
- 26 Although these "General Conditions of Sale" have also been drawn up in English and French, in case of discrepancies between the Italian version and any other language versions, the Italian version shall prevail, to be considered, therefore, as the only authentic text.

Conditions générales de vente Alpi

- 1 Les commandes devront être transmises au revendeur par écrit, en précisant les données complètes des articles, la quantité, les remises et autres données importantes relatives à chaque article. Alpi ne sera pas tenue d'envoyer une confirmation de commande, à savoir, dans le cas présent, le contrat d'achat et de vente conclu, aux termes et en exécution de l'art. 1327, premier alinéa du Code civil italien, au moment du début de l'exécution des commandes individuelles par Alpi, avec décharge de cette dernière de l'obligation de fournir sans délai un avis au revendeur du commencement de l'exécution. Les commandes ne contraignent pas Alpi qui a la faculté de les accepter ou de les refuser, à sa seule discrétion. Même après son éventuelle acceptation de la commande, même si exprimée, et en cas de non disponibilité des produits ou en cas de force majeure, Alpi se réserve le droit d'exécuter ou non les commandes. En cas de non-exécution de la commande acceptée par Alpi, cette dernière s'engage uniquement à en informer sans délai le revendeur, lequel renonce à demander, dès lors, d'éventuelles pénalités et/ou la réparation d'éventuels dommages.
- 2 Les conditions de livraison, si indiquées, ont une valeur purement indicative et en aucun cas obligatoire (en fonction de l'approvisionnement des produits à fournir au revendeur ainsi que de facteurs indépendants du contrôle de Alpi) ; chaque retard éventuel de Alpi ne pourra jamais constituer une source de réparation de dommages, ni entraîner la résolution du contrat, ni ne pourra légitimer les demandes de pénalités, de réduction des prix et/ou le report du paiement par le revendeur.
- 3 La localisation des marchandises ainsi que le transfert de propriété auront lieu lorsque les marchandises seront confiées au transporteur.
- 4 Les frais de transport et d'assurance ainsi que les risques associés au transport sont à la charge du revendeur et la remise (et le retour) de produits est réalisée dans le magasin Alpi à Gattico Veruno (EXW – franco usine), sauf accord écrit différent entre les parties. Nonobstant ce qui précède, le choix de l'expéditeur et/ou du transporteur peut également être effectué par Alpi S.p.A. Dans tous les cas, Alpi ne sera pas responsable des retards de livraison, de la perte et/ou de l'avarie des marchandises qui pourraient survenir pendant le transport.
- 5 Alpi fournit à l'utilisateur final une « garantie standard » qui est additionnelle et qui ne se substitue pas aux autres droits dont jouit le « consommateur » du produit à l'égard de la partie auprès de laquelle il a acheté le bien. En particulier, la garantie standard fournie par Alpi n'affecte pas les droits dont le « consommateur » est titulaire aux termes du décret législatif italien n° 206 du 6 septembre 2005 et modifications et ajouts successifs. Par « garantie standard », on entend exclusivement la réparation et/ou le remplacement gratuit des pièces mécaniques des produits vendus par Alpi, comportant un défaut de fabrication ou du matériau, ainsi que la réparation et/ou le remplacement des parties des produits vendus par Alpi qui présentent de graves défauts au niveau de la finition superficielle externe (par exemple, le chromage) dus à la fabrication ou au matériau, à condition que les produits susmentionnés soient accompagnés d'une facture ou d'un ticket de caisse d'achat. Dans tous les cas, Alpi se réserve le droit, à sa seule discrétion, de pourvoir au remplacement du produit défectueux par un produit similaire ou de meilleure qualité. Le remplacement et/ou la réparation des produits et/ou des composants défectueux sont soumis à l'envoi du produit et/ou composant défectueux par le revendeur au siège de Alpi. Il convient de noter que la « garantie standard » reconnue par Alpi S.p.A. ne comprend pas tous les coûts de main-d'œuvre, des matériaux (y compris expressément les revêtements de toutes sortes, et notamment, sans toutefois s'y limiter : carreaux, pierres, métaux, bois, porcelaines, textiles, désormais, par souci de concision, les revêtements), le coût des éventuels meubles et décorations, résultant de la nécessité de désinstaller (et/ou de rendre accessible pour l'intervention) et de réinstaller les produits défectueux (par exemple, mais sans toutefois s'y limiter, les produits intégrés dans des meubles et/ou murs). La « garantie standard » reconnue par Alpi, par conséquent, ne comprend pas les frais, coûts et/ou dommages aux revêtements, au mobilier et/ou à la décoration causés par la désinstallation et la réinstallation des produits défectueux. La durée de la garantie standard reconnue par Alpi S.p.A. est normalement (sauf indication claire dans le certificat de garantie qui accompagne chaque produit) de cinq ans après la date d'achat par l'utilisateur final des produits vendus par Alpi au revendeur. La garantie standard ne prend effet que si les produits vendus par Alpi ont été utilisés normalement, et en s'applique pas aux dommages causés par la négligence, l'utilisation, l'installation, l'entretien et/ou le nettoyage incorrect ou non conforme au manuel d'instruction précité, aux endommagements, à la détérioration provoqués par la foudre, les phénomènes atmosphériques, les surtensions et les surintensités, l'alimentation électrique insuffisante ou irrégulière, et/ou d'autres causes de force majeure, ni aux dommages intervenus lors du transport et/ou du fait client et/ou de tiers, ni pour les dommages dus à des contraventions aux règles de sécurité ou aux exigences techniques du pays dans lequel le produit est utilisé. En outre, la garantie standard ne s'applique pas dans les cas suivants : 1) modifications, falsifications et/ou utilisation d'accessoires en option non originaux fournis par des tiers et appliqués aux produits ; 2) utilisation de pièces de rechange n'étant pas d'origine Alpi ; 3) rupture et/ou mauvais fonctionnement dû au gel, à tout type d'impureté présente dans les tuyaux, à de l'eau calcaire ; 4) détérioration des finitions due à l'utilisation de produits agressifs, acides et/ou une forte teneur en chlore dans l'eau ; 6) dysfonctionnement et/ou fonctionnement inadapté dû au sable, à des débris et/ou à des impuretés présentes dans l'eau ; 7) non-utilisation de réducteurs de pression et de filtres appropriés en amont de l'installation ; 8) pressions ou températures non conformes aux paramètres indiqués dans le manuel d'instruction et/ou dans les étiquettes d'avertissement accompagnant les produits. Il convient de noter que la présente garantie standard ne couvre pas l'entretien de routine et le remplacement de toutes les parties considérées « d'usure » et/ou soumises à une usure normale. En signant pour acceptation ces Conditions générales de vente, la garantie légale pour défaut des produits vendus par Alpi au revendeur reste expressément exclue. Le revendeur, bien que reconnu responsable à l'égard du consommateur final pour les défauts des produits susmentionnés, ne pourra agir en recours contre Alpi. Par conséquent, le revendeur renonce au droit de la garantie légale et des actions connexes ainsi qu'au droit de se retourner contre Alpi même pour les dommages et/ou dépenses éventuellement encourus.
- 6 Les prix sont ceux résultant des catalogues des prix Alpi en vigueur au moment de l'expédition des marchandises, ou du moins ceux normalement pratiqués par Alpi. Alpi sera autorisée à modifier les prix indiqués dans les catalogues des prix avec un préavis de 15 jours, et donc sans influence, en cas d'augmentation ou de diminution, sur les commandes déjà acceptées à la date de la transmission du susdit avis de modification, qui seront donc réglées au prix non encore modifié.
- 7 Les paiements seront effectués par le revendeur en euro. Les conditions et modalités de paiement sont celles convenues entre Alpi et le revendeur et sont considérées comme obligatoires et essentielles dans l'intérêt de Alpi. En l'absence de stipulations des conditions et modalités de paiement, celles indiquées sur la facture de Alpi prévaudront. Dans tous les cas, Alpi a le droit d'exiger l'exécution du contrat sans la charge de communication mentionnée à l'art. 1457 du Code civil italien. Alpi se réserve le droit de modifier et de communiquer par écrit les différentes conditions de paiement et/ou modalités de paiement : dans ce cas, les nouvelles conditions et/ou modalités de paiement seront réputées acceptées par le revendeur si ce dernier ne communique pas par écrit à Alpi le refus des unes et/ou des autres au plus tard quinze (quinze) jours suivant la réception de l'information corrélative de modification de la part de Alpi.
- 8 Le défaut et/ou retard de paiement conformément aux conditions indiquées sur la commande du revendeur acceptée par Alpi ou, en l'absence, sur la facture de Alpi impliquera l'application d'intérêts de retards déterminés conformément à l'art. 5 du décret législatif italien 231/2002 et modifications et ajouts successifs. En outre, en cas de défaut et/ou de retard de paiement conformément aux conditions définies, Alpi pourra suspendre, à sa discrétion absolue, jusqu'au paiement intégral des sommes dues, toutes ou parties des commandes transmises par le revendeur et les éventuels services fournis à celui-ci, et modifier les conditions et/ou les modalités de paiement avec effet immédiat sur simple communication écrite. Après 15 jours de défaut et/ou de retard de paiement, Alpi pourra annuler en tout ou en partie, à son entière discrétion, les commandes non exécutées même si déjà acceptées.
- 9 Le paiement du prix des marchandises doit être effectué au domicile de la société Alpi à Gattico Veruno (NO), Via Geola n.9; les éventuels paiements effectués dans des lieux autres que l'adresse de Alpi mentionnée ci-dessus, même si cette dernière l'accepte, auront valeur de simple tolérance et ne pourront jamais constituer une modification du principe du paiement à l'adresse indiquée.
- 10 Le paiement effectué par le biais de chèques de banque et/ou bancaires, même si cette méthode s'avère acceptée par Alpi, est aux risques et périls du revendeur dans le sens où ce dernier n'est pas libéré de son obligation de paiement si la preuve de l'encaissement effectif par Alpi n'est pas avérée. Nonobstant ce qui précède, il reste également entendu que, en cas de vol et/ou de perte de chèques envoyés par le revendeur, même si cela a lieu après qu'ils aient été reçus par Alpi et/ou par ses employés et/ou agents, Alpi est dès lors expressément exempté de toute responsabilité à cet égard, ainsi que de devoir demander la duplicata des chèques et/ou l'amortissement de ces derniers.
- 11 Les illustrations et les informations contenues dans les dépliants, les catalogues des prix, le site Web de Alpi, les fiches descriptives des produits Alpi et dans tout autre support d'information et/ou publicitaire, quel que soit le moyen utilisé, même si elles représentent chaque article, ne constituent pas un engagement d'exécution fidèle à la charge de Alpi. Par conséquent, les poids et mesures indiqués doivent être considérés à titre indicatif et, par conséquent, Alpi n'assume aucune responsabilité à cet égard. Alpi se réserve quoi qu'il en soit le droit d'apporter aux produits commercialisés, à tout moment, toutes les modifications qu'elle juge nécessaire afin d'optimiser la production, indépendamment de la façon dont ils sont représentés et décrits dans les catalogues des prix, dans les fiches descriptives des produits, dans le site Web de Alpi et, de toute façon, dans n'importe quel support approprié à la promotion et à la vente de produits. Les déclarations, promesses, conditions et garanties provenant des employés, représentants, agents et prospecteurs qui diffèrent des conditions de vente ici reproduites, et dans tous les cas toutes celles non incluses dans les actes signés par les représentants légaux de Alpi, n'engagent pas Alpi.

- 12 Il est établi d'un commun accord que pour le règlement de tout différend éventuel relatif à l'interprétation, à l'exécution et à la résiliation des présentes Conditions générales de vente ou relatif aux rapports de vente et d'achat qui lient les parties ou, de toute façon, relatif à toute question reliée et/ou connectée à celles-ci, le tribunal de Milan des autorités judiciaires italiennes sera le seul compétent.
- 13 Le revendeur ne pourra pas soumettre des questions, des actions, ni soulever des objections à l'encontre de Alpi, sauf après avoir effectué le paiement de la totalité du montant dû à cette dernière en capital, intérêt et dépenses liés à la fourniture des marchandises. En outre, il est convenu que le revendeur ne pourra compenser ses éventuelles créances avec les sommes dues à Alpi par l'acquisition de marchandises.
- 14 Les prix éventuellement indiqués dans les catalogues et listes des prix sont exclusivement considérés comme des prix conseillés au public, exprimés en euros, TVA non comprise.
- 15 La loi applicable est exclusivement la loi italienne, à l'exclusion expresse des autres lois nationales et/ou conventions internationales sur la vente internationale de marchandises.
- 16 Les conditions, termes et modalités de paiement, ainsi que les remises financières et/ou commerciales, ainsi que les contributions et/ou primes éventuellement prévues, seront toujours subordonnés à la condition que le paiement des fournitures soit effectué par le revendeur conformément aux termes prévus.
- 17 Le paiement de tous les impôts, taxes, droits, charges fiscales et/ou administratives, ainsi que les coûts et les dépenses de toute nature prévus par des organismes d'état, gouvernementaux et/ou administratifs relatifs à l'achat, à l'importation, à l'exportation et à la revente des produits acquis auprès de Alpi seront à la charge du revendeur.
- 18 Les présentes conditions de vente ne constituent pas une obligation d'achat pour le revendeur, ni une obligation de vente pour Alpi. Par conséquent, il n'y aura aucune obligation entre les parties de fourniture, ni aucune forme d'exclusivité ne sera conférée, compte tenu de la simple relation contractuelle d'achat et de vente qui lie les parties.
- 19 La tolérance éventuelle à l'égard des violations et/ou comportements contraires à ces Conditions générales de vente ne pourra être considérée comme une renonciation des présentes expressément prévu ni ne pourra infirmer la validité des clauses non observées. En cas de nullité d'une ou plusieurs des présentes clauses ou d'une partie de celles-ci, en raison d'un conflit avec les termes impératifs de la loi, ces dispositions sont réputées substituées de droit, dans les limites du conflit prévu par la loi.
- 20 Sauf en cas de dol ou de faute grave de Alpi S.p.A., la responsabilité et le montant consécutif du dédommagement éventuellement dû par Alpi au revendeur sont limités au prix d'achat par le revendeur du produit ou des produits Alpi faisant l'objet d'une contestation et/ou faute.
- 21 Les conditions contractuelles différentes des présentes Conditions générales de vente de Alpi, même si rappelées, ajoutées, modifiées, et/ou insérées dans les commandes ou dans toute communication du revendeur, ne seront valables que si elles sont expressément et spécifiquement acceptées par écrit par un représentant autorisé de Alpi S.p.A.
- 22 Le revendeur reconnaît que la société et la marque utilisée par Alpi sont la propriété exclusive de cette dernière. Le revendeur ne pourra pas revendiquer des droits ou la propriété de l'entreprise ou de la marque mentionnées ci-dessus. Ceci, ni directement ni indirectement, par une personne, société et/ou un organisme interposé. L'utilisation de la marque ALPI par le revendeur, là où autorisée, se fera en conformité avec les directives établies par Alpi. En cas d'apposition de la marque ALPI sur l'enseigne du revendeur, en plus d'être préalablement autorisée par écrit par Alpi, le revendeur sera tenu au paiement de tout impôt et/ou taxe légal, y compris ceux relatifs à la publicité. La marque qui apparaît sur le matériel promotionnel éventuellement fourni par Alpi au revendeur est exclue : dans ce cas, le revendeur n'aura pas besoin d'une autorisation de Alpi. Dans tous les cas, le revendeur s'abstiendra de promettre ou représenter à toute personne, oralement ou par écrit, des prestations autres que celles prévues dans les catalogues, dépliants, fiches descriptives des produits, manuels d'instructions et, en général, dans le matériel publicitaire ou d'illustration fourni par Alpi. Le revendeur est tenu de veiller à ce que toutes les formes de publicité, réalisée par ce dernier, dans lequel apparaissent les produits Alpi sont conformes à la réglementation en vigueur de la loi sur la publicité.
- 23 Toutes les données personnelles reçues en vertu des relations contractuelles régies par les présentes Conditions générales de vente seront traitées sous forme électronique et sur papier. Les données peuvent être communiquées par Alpi, dans le cadre de ses compétences respectives et spécifiques, à des conseillers fiscaux, sociétés de révision comptable, professionnelles, organismes publics, établissements de crédit, agents d'affaires, promoteurs, marchandiseurs, centres d'assistance technique, à l'égard desquels il y a pour Alpi l'obligation, ou la nécessité ou la possibilité de communication, et ce également aux fins d'un meilleur accomplissement de chaque obligation contractuelle respective.
- 24 Le revendeur ne pourra céder, en totalité ou en partie, sans le consentement préalable écrit de Alpi, les droits et obligations prévus dans les présentes Conditions générales de vente, ni les éventuelles créances opposables à Alpi S.p.A.
- 25 Le revendeur s'engage à garder confidentielles toutes les informations de toute nature et dans tous les cas acquis au cours de l'exécution des prestations régies par les présentes Conditions générales de vente. En particulier, le revendeur s'engage à ne divulguer à des tiers aucune information obtenue au cours de l'exécution des prestations réglementées par les Conditions générales de vente, et à mettre en place toutes les précautions nécessaires afin que ses employés et/ou collaborateurs se conforment à de telles dispositions, le tout également en pleine conformité avec les dispositions du décret législatif italien n° 196/2003. A cet effet, il est établi que : toutes les informations, quel que soit le mode d'acquisition/de collecte par le revendeur ne seront pas utilisées, ni distribuées ou communiquées à des tiers à des fins autres que celles prévues par les présentes Conditions générales de vente, sous réserve, toutefois, des cas où (i) il est nécessaire d'obtempérer aux obligations réglementaires ou légales, ou à la demande des autorités italiennes ou étrangères auxquelles il n'est pas possible d'opposer un refus, ou (ii) de telles informations sont déjà dans le domaine public ou sont devenues publiques autrement que par la violation des obligations de confidentialité en accord avec les présentes Conditions générales de vente. Le revendeur s'engage à communiquer et à faire respecter les obligations en matière de confidentialité mentionnées dans le présent engagement à ses employés et à tous ceux qui, pour une raison quelconque, collaborent ou ont collaboré à l'exécution des prestations couvertes par les présentes Conditions générales de vente. Les prévisions et interdictions visées au présent article resteront en vigueur même après l'éventuelle résolution, annulation ou résiliation pour une raison quelconque de la relation contractuelle qui lierait Alpi et le revendeur.
- 26 Bien que les présentes « Conditions générales de vente » soient rédigées en anglais, français, en cas de divergence entre le texte écrit en italien et celui écrit dans une autre langue, le texte italien, comme indiqué dans celui-ci, sera le seul faisant foi comme texte original.

Alpi si riserva il diritto di apportare i cambiamenti che ritiene opportuni ad articoli e finiture al fine di migliorare il prodotto.

Le illustrazioni e le descrizioni contenute nei ns. stampati non comportano obbligo di fedele riproduzione, i dettagli e le misure sono da considerarsi indicativi e soggetti a modifiche senza preavviso.

Alpi reserves the right to introduce the proper changes to the items and finishing in order to improve the product.

Pictures and descriptions are not engaging us of accurate execution, details and sizes are merely indicatives and can be modified without notice.

Alpi se réserve le droit d'apporter des modifications aux produits et finitions afin de les améliorer sans préavis. Les photos et les désignations ne sont pas contractuelles, les détails et les mesures sont indicatives.

Alpi garantisce la disponibilità dei propri ricambi. Nel caso in cui sia necessario un ricambio non riportato nel presente listino prezzi va richiesto direttamente all'azienda, specificando la serie scelta e l'articolo di riferimento.

Alpi guarantees the availability of its spare parts. Should a spare part which is not indicated in the present price list be required, it must be requested directly from the company, specifying the selected series and the reference item.

Alpi garantit la disponibilité de ses propres pièces de rechange. En cas de besoin d'une pièce de rechange qui ne serait pas présente dans la liste des prix, celle-ci doit être demandée directement auprès de l'entreprise, en spécifiant la série choisie et la référence de l'article.

