

Albatros

01 | 26

LISTINO PREZZI // PRICE LIST
LISTE DE PRIX // LISTA DE PRECIOS
PREISLISTE

Albatros

**01 Saune e Hammam
/ Saunas and Hammam**

- 014 Ethix
- 018 Soha
- 022 Hammam Plus
- 024 Hammam Plus Enclosures

**02 Minipiscine Secret System
/ Secret System SPA**

- 028 Syraka Pool
- 030 Kellia Pool
- 032 Modula Pool

**03 Minipiscine Glamour
/ Glamour SPA**

- 036 Thea
- 038 Soreha
- 040 Oniris
- 042 Miris
- 044 Elite
- 046 Marvelia
- 048 Soreha Mini
- 050 Aster

**04 Minipiscine Privè
/ Privè SPA**

- 054 Privè R07
- 056 Privè 405
- 058 Privè 306
- 060 Privè 206
- 062 Privè 103

**05 Minipiscine Overflow
/ Overflow SPA**

- 066 Beverly
- 068 Forever
- 070 Kristal XL
- 072 Kristal L

**06 Minipiscine Swim
/ Swim SPA**

- 076 Harry Swim 1
- 078 Harry Swim 2
- 080 Harry Swim 3

**07 Accessori
/ Accessories**

- 084 Scalette / Steps
- 086 Coperture / Covers
- 088 Kit Pulizia / Cleaning kit
- 088 Kit Manutezione / Kit Maintenance
- 089 Poggiatesta / Headrests

**08 Colonne da esterno
/ Outdoor columns**

- 092 Solaris
- 094 Natura
- 096 Horizon

**09 Vasche Secret System
/ Bathtubs Secret System**

- 100 Syraka
- 102 Kellia
- 104 Tarim

**10 Vasche Glamour
/ Bathtubs Glamour**

- 108 Soreha Mini Bath
- 110 Marvelia Bath
- 112 Aster Bath
- 114 Miris Bath

**11 Vasche Talima
/ Bathtubs Talima**

- 118 Talima Freestanding
- 120 Talima Panel
- 122 Talima Wall

**12 Vasche Ethos
/ Bathtubs Ethos**

- 126 Ethos Color
- 128 Ethos Plus
- 130 Ethos Panel
- 132 Ethos Wall
- 134 Ethos 90°140
- 136 Ethos Round 180

**13 Vasche Altea
/ Bathtubs Altea**

- 140 Altea 167-177-178-188
- 142 Altea 160
- 144 Altea 90°125
- 146 Altea 90°150
- 148 Altea Round 160

**14 Vasche Idea
/ Bathtubs Idea**

- 152 Idea F Oval
- 154 Idea F Rectangular
- 156 Idea 147-157-167-177
- 158 Idea 90°140
- 160 Idea 158

**15 Servizi generali
/ General services**

- 164 Funzioni Sauna e Hammam
/ Sauna and Hammam functions
- 166 Funzioni Minipiscine
/ SPA functions
- 174 Green Plus
- 176 Cura e Manutezione
/ Care and maintenance
- 178 Condizioni Generali di vendita
/ General sales conditions
- 183 Finiture / Finishings

Vasche / Bathtubs / Baignoires / Bañeras / Badewannen

	Rettangolare / Rectangular / Rectangulaire Rectangular / Rechteckig								
	140 cm	141 cm	150 cm	160 cm	170 cm	180 cm	190 cm	196 cm	200 cm
Syraka		169 cm pag. 100							
Kellia				170 cm pag. 102					
Tarim									
Soreha Mini						180 cm pag. 108			
Aster Mini	140 cm pag. 112								
Marvelia mini							120 cm pag. 110		
Miris Mini									50 cm pag. 111
Talima					70 cm pag. 118			88 cm pag. 120	
Altea					70 cm pag. 140	80 cm pag. 140			
					80 cm pag. 140				
Ethos					70 cm f col. pag. 126	80 cm pag. 130		87 cm pag. 132	
					75 cm f plus pag. 128				
Idea	70 cm pag. 156		70 cm pag. 154		70 cm pag. 156	70 cm pag. 156			
				80 cm oval pag. 152					
				80 cm rect. pag. 154					

			90 gradi / 90 degrees 90 degrés 90 grados / 90 Grad			Vela / Sail / Voile Vela / Segel		round	
cm	202 cm	180 ~ 220 cm	125 cm	140 cm	150 cm	150 cm	160 cm	160 cm	180 cm
	84 cm pag. 104								
		180~220 cm pag. 122							
			125 cm pag. 144		150 cm pag. 146		100 cm pag. 142	160 cm pag. 148	
		180~220 cm pag. 130		140 cm pag. 134					180 cm pag. 136
				140 cm pag. 158		80 cm pag. 160			

I Massaggi di Albatros

/ The Albatros Massages / Les massages Albatros / Los masajes Albatros / Die Albatros-Massagen



Abbraccio D'Acqua

→ L'acqua avvolge la schiena in modo uniforme, creando una sensazione di accoglienza e continuità.
/ The water envelops the back evenly, creating a feeling of comfort and continuity / L'eau enveloppe le dos de manière uniforme, créant une sensation d'accueil et de continuité / El agua envuelve la espalda de manera uniforme, creando una sensación de acogida y continuidad / Das Wasser umhüllt den Rücken gleichmäßig und erzeugt ein Gefühl von Geborgenheit und Kontinuität.



Ali di Energia

→ Azione mirata nella parte alta della schiena che aiuta a sciogliere le tensioni e favorisce leggerezza.
/ Targeted action on the upper back that helps release tension and promotes a feeling of lightness / Action ciblée sur le haut du dos qui aide à relâcher les tensions et favorise une sensation de légèreté / Acción dirigida en la parte alta de la espalda que ayuda a liberar tensiones y favorece una sensación de ligereza / Gezielte Wirkung im oberen Rückenbereich, die hilft, Spannungen zu lösen und ein Gefühl von Leichtigkeit zu fördern



Armonia Totale

→ Massaggio regolare e uniforme alla schiena che favorisce equilibrio e continuità.
/ Regular, even massage along the back that promotes balance and continuity / Massage régulier et uniforme du dos qui favorise équilibre et continuité / Masaje regular y uniforme en la espalda que favorece el equilibrio y la continuidad / Gleichmäßige und regelmäßige Rückenmassage, die Ausgeglichenheit und Kontinuität fördert



Avvolgente

→ L'acqua accompagna il corpo in modo continuo, creando una sensazione di protezione e uniformità.
/ The water flows continuously along the body, creating a sense of protection and uniformity / L'eau accompagne le corps de manière continue, créant une sensation de protection et d'uniformité / El agua acompaña el cuerpo de forma continua, creando una sensación de protección y uniformidad / Das Wasser umspielt den Körper kontinuierlich und vermittelt ein Gefühl von Schutz und Gleichmäßigkeit



Benessere Mirato

→ Un massaggio preciso, dedicato a zone specifiche del corpo.
/ A precise massage focused on specific areas of the body / Un massage précis dédié à des zones spécifiques du corps / Un masaje preciso dedicado a zonas específicas del cuerpo / Eine präzise Massage für gezielte Körperbereiche



Benessere Profondo

→ Un'azione avvolgente che lavora in profondità, pensata per un benessere più strutturato.
/ An enveloping action that works deep into the body, designed for more structured well-being / Une action enveloppante qui agit en profondeur, pensée pour un bien-être plus structuré / Una acción envolvente que actúa en profundidad, pensada para un bienestar más estructurado / Eine umhüllende Wirkung, die tiefgehend wirkt und für ein strukturierteres Wohlbefinden konzipiert ist.



Comfort

→ Un massaggio accogliente che sostiene il corpo e favorisce il rilassamento.
/ A welcoming massage that supports the body and promotes relaxation / Un massage enveloppant qui soutient le corps et favorise la détente / Un masaje acogedor que sostiene el cuerpo y favorece la relajación / Eine wohltuende Massage, die den Körper unterstützt und die Entspannung fördert.



Corrente Morbida







→ Azione delicata che scorre sulla schiena, ideale per un rilassamento graduale.
/ Gentle action flowing along the back, ideal for gradual relaxation / Action délicate qui glisse le long du dos, idéale pour une détente progressive / Acción delicada que recorre la espalda, ideal para una relajación gradual / Sanfte Wirkung, die entlang des Rückens fließt und ideal für eine schrittweise Entspannung ist

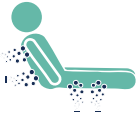

Distensione

→ Favorisce il rilascio della parte superiore del corpo, accompagnando respiro e postura.
/ Promotes the release of the upper body, supporting breathing and posture / Favorise le relâchement de la partie supérieure du corps, en accompagnant la respiration et la posture / Favorece la liberación de la parte superior del cuerpo, acompañando la respiración y la postura / Fördert die Entspannung des Oberkörpers und unterstützt Atmung und Körperhaltung.

-  **Equilibrio** → Massaggio continuo alla schiena, per una sensazione di equilibrio.
/ Continuous back massage for a sense of balance / Massage continu du dos pour une sensation d'équilibre / Masaje continuo en la espalda para una sensación de equilibrio / Kontinuierliche Rückenmassage für ein Gefühl von Ausgeglichenheit
-  **Energia Totale** → Coinvolge più aree del corpo, favorendo una sensazione di attivazione equilibrata.
/ Engages multiple areas of the body, promoting a sense of balanced activation / Implique plusieurs zones du corps, favorisant une sensation d'activation équilibrée / Involucra varias áreas del cuerpo, favoreciendo una sensación de activación equilibrada / Bezieht mehrere Körperbereiche ein und fördert ein Gefühl ausgewogener Aktivierung
-  **Flusso Vitale** → Massaggio delicato che avvolge schiena e cosce, per una sensazione di leggerezza.
/ Gentle massage that envelops the back and thighs, creating a feeling of lightness / Massage délicat qui enveloppe le dos et les cuisses, pour une sensation de légèreté / Masaje delicada que envuelve la espalda y los muslos, para una sensación de ligereza / Sanfte Massage, die Rücken und Oberschenkel umhüllt und ein Gefühl von Leichtigkeit vermittelt.
-  **Leggerezza** → Riduce la sensazione di peso sulla schiena, favorendo una percezione di equilibrio.
/ Reduces the feeling of heaviness on the back, promoting a sense of balance / Réduit la sensation de poids sur le dos, favorisant une perception d'équilibre / Reduce la sensación de peso en la espalda, favoreciendo una percepción de equilibrio / Reduziert das Schweregefühl im Rücken und fördert ein Gefühl von Ausgeglichenheit.
-  **Mirato** → Massaggio localizzato alla schiena con getto preciso e mirato.
/ Localized back massage with a precise, targeted jet / Massage localisé du dos avec jet précis et ciblé / Masaje localizado en la espalda con chorro preciso y dirigido / Lokalisierte Rückenmassage mit präzisiertem, gezieltem Wasserstrahl.
-  **Movimento** → Avvolge la schiena con una sensazione di benessere diffuso.
/ Envelops the back with a sensation of widespread well-being / Enveloppe le dos d'une sensation de bien-être diffus / Envuelve la espalda con una sensación de bienestar generalizado / Umhüllt den Rücken mit einem Gefühl umfassenden Wohlbefindens
-  **Onda di Benessere** → Flusso morbido e avvolgente per una sensazione di comfort diffuso.
/ Soft, enveloping flow for a feeling of widespread comfort / Flux doux et enveloppant pour une sensation de confort diffus / Flujo suave y envolvente para una sensación de confort generalizado / Sanfter, umhüllender Wasserfluss für ein Gefühl umfassenden Komforts
-  **Onda Suprema** → Un'azione più intensa che attraversa il corpo con decisione, mantenendo fluidità e comfort.
/ A more intense action that moves decisively through the body while maintaining fluidity and comfort / Une action plus intense qui traverse le corps avec détermination, tout en conservant fluidité et confort / Una acción más intensa que recorre el cuerpo con determinación, manteniendo fluidez y confort / Eine intensivere Wirkung, die den Körper entschlossen durchströmt und dabei Flüssigkeit und Komfort bewahrt.
-  **Radici di Benessere** → Massaggio avvolgente che coinvolge schiena e gambe, per una sensazione di energia e sostegno.
/ Enveloping massage involving back and legs, for a feeling of energy and support / Massage enveloppant impliquant le dos et les jambes, pour une sensation d'énergie et de soutien / Masaje envolvente que involucra espalda y piernas, para una sensación de energía y sostén / Umhüllende Massage, die Rücken und Beine einbezieht und ein Gefühl von Energie und Unterstützung vermittelt
-  **Radici Forti** → Azione intensa sulla schiena, per una sensazione di forza e benessere.
/ Intense action on the back, for a feeling of strength and well-being / Action intense sur le dos, pour une sensation de force et de bien-être / Acción intensa en la espalda, para una sensación de fuerza y bienestar / Intensive Wirkung auf den Rücken, für ein Gefühl von Kraft und Wohlbefinden.
-  **Respiro Profondo** → Azione distensiva sulla schiena, per un respiro più ampio.
/ Relaxing action on the back, for deeper breathing / Action relaxante sur le dos, pour une respiration plus ample / Acción distensiva en la espalda, para una respiración más amplia / Entspannende Wirkung auf den Rücken, für eine tiefere Atmung
-  **Risveglio Dolce** → Un'azione leggera e progressiva, ideale per una riattivazione graduale.
/ A light, progressive action, ideal for gradual reactivation / Une action légère et progressive, idéale pour une réactivation graduelle / Una acción ligera y progresiva, ideal para una reactivación gradual / Eine leichte, progressive Wirkung, ideal für eine schrittweise Reaktivierung.

-  **Serenità** → Un massaggio regolare e delicato che accompagna verso una sensazione di calma.
/ *A gentle, steady massage that leads toward a feeling of calm / Un massage régulier et délicat qui accompagne vers une sensation de calme / Un masaje regular y delicado que conduce hacia una sensación de calma / Eine gleichmäßige und sanfte Massage, die zu einem Gefühl der Ruhe führt.*
-  **Sollievo** → Un massaggio pensato per sciogliere le tensioni quotidiane e favorire una sensazione immediata di calma.
/ *A massage designed to release everyday tension and promote an immediate sense of calm / Un massage conçu pour relâcher les tensions quotidiennes et favoriser une sensation immédiate de calme / Un masaje pensado para aliviar las tensiones cotidianas y favorecer una sensación inmediata de calma / Eine Massage, die darauf ausgelegt ist, alltägliche Spannungen zu lösen und ein unmittelbares Gefühl der Ruhe zu fördern.*
-  **Sollievo Profondo** → Agisce in modo più deciso sulla zona lombare, aiutando a ridurre le tensioni profonde.
/ *Acts more decisively on the lumbar area, helping to reduce deep tension / Agit de manière plus ciblée sur la zone lombaire, aidant à réduire les tensions profondes / Actúa de forma más decidida en la zona lumbar, ayudando a reducir las tensiones profundas / Wirkt gezielt auf den Lendenbereich und hilft, tiefsitzende Spannungen zu reduzieren.*
-  **Sospiro** → Un massaggio leggero, che accompagna il respiro, favorendo il rilascio delle tensioni.
/ *A light massage that follows the breath, promoting the release of tension / Un massage léger qui accompagne la respiration, favorisant le relâchement des tensions / Un masaje ligero que acompaña la respiración, favoreciendo la liberación de las tensiones / Eine leichte Massage, die den Atem begleitet und das Lösen von Spannungen fördert.*
-  **Sostegno** → Massaggio che sostiene la schiena, con attenzione alla zona lombare, favorendo comfort e rilassamento.
/ *Massage that supports the back, with focus on the lumbar area, promoting comfort and relaxation / Massage qui soutient le dos, avec une attention particulière à la zone lombaire, favorisant confort et détente / Masaje que sostiene la espalda, con atención a la zona lumbar, favoreciendo confort y relajación / Massage, die den Rücken unterstützt, mit besonderem Fokus auf den Lendenbereich, und Komfort sowie Entspannung fördert.*
-  **Sostegno Avvolgente** → Massaggio avvolgente dedicato alla schiena alta, che dona sostegno e una sensazione di distensione profonda.
/ *Enveloping massage dedicated to the upper back, providing support and a feeling of deep release / Massage enveloppant dédié au haut du dos, apportant soutien et sensation de détente profonde / Masaje envolvente dedicado a la parte alta de la espalda, que aporta sostén y una sensación de distensión profunda / Umhüllende Massage für den oberen Rücken, die Unterstützung bietet und ein Gefühl tiefer Entspannung vermittelt.*
-  **Vitalità** → Un'azione dinamica che stimola il corpo, favorendo una sensazione di energia e riattivazione generale.
/ *Dynamic action that stimulates the body, promoting a feeling of energy and overall reactivation / Action dynamique qui stimule le corps, favorisant une sensation d'énergie et de réactivation générale / Acción dinámica que estimula el cuerpo, favoreciendo una sensación de energía y reactivación general / Dynamische Wirkung, die den Körper stimuliert und ein Gefühl von Energie sowie allgemeiner Reaktivierung fördert*

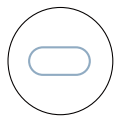

Secret System

Nessuna bocchetta interrompe la superficie della vasca, solo dei tagli sottili e minimali posizionati per garantire la massima ergonomia dei getti idromassaggio.

/ No nozzles interrupt the surface of the bathtub; only thin, minimal slits are positioned to ensure maximum ergonomic performance of the hydromassage jets.

/ Aucune buse n'interrompt la surface de la baignoire : seuls de fines découpes minimalistes sont positionnées afin de garantir une ergonomie optimale des jets d'hydromassage.

/ Ninguna boquilla interrumpe la superficie de la bañera; solo finas ranuras minimalistas están posicionadas para garantizar la máxima ergonomía de los chorros de hidromasaje.

/ Keine Düsen unterbrechen die Oberfläche der Badewanne; lediglich feine, minimalistische Schlitzlöcher sind so positioniert, dass maximale Ergonomie der Hydromassage-Düsen gewährleistet wird.

→ Kellia, Modula, Syraka



Scopri il funzionamento Secret System

/ Discover how Secret System works

/ Découvrez le fonctionnement de Secret System

/ Descubra el funcionamiento de Secret System

/ Entdecken Sie die Funktionsweise von Secret System

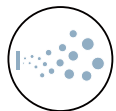

Whirlpool

Le minipiscine Albatros sono dotate di funzione Airpool (idromassaggio ad aria) e Whirlpool (idromassaggio ad acqua/aria).

L'esclusivo Albatros SPA System, di tipo Whirlpool, agisce attraverso la reimmissione dell'acqua, miscelata all'aria, nella vasca.

/ Albatros mini pools are equipped with the Airpool function (air hydromassage) and Whirlpool function (water/air hydromassage). The exclusive Albatros SPA System, of the Whirlpool type, operates by reintroducing water mixed with air into the tub.

/ Les minipiscines Albatros sont équipées de la fonction Airpool (hydromassage à air) et de la fonction Whirlpool (hydromassage eau/air). L'exclusif Albatros SPA System, de type Whirlpool, agit par la réinjection de l'eau, mélangée à l'air, dans la cuve.

/ Las minipiscinas Albatros están equipadas con la función Airpool (hidromasaje de aire) y Whirlpool (hidromasaje de agua/aire). El exclusivo Albatros SPA System, de tipo Whirlpool, actúa mediante la reintroducción del agua, mezclada con aire, en la bañera.

/ Die Albatros Minipools sind mit der Airpool-Funktion (Luftmassage) und der Whirlpool-Funktion (Wasser-/Luftmassage) ausgestattet.

/ Das exklusive Albatros SPA System vom Typ Whirlpool wirkt durch die Wiedereinleitung von mit Luft vermischem Wasser in die Wanne.

→



Scopri i nostri sistemi di idromassaggio

/ Discover our hydromassage systems

/ Découvrez nos systèmes de hydromassage

/ Descubre nuestros sistemas de hidromasaje

/ Entdecken Sie unsere Hydromassage-Systeme



Airpool

Il sistema idromassaggio Airpool immette aria nell'acqua attraverso le apposite bocchette posizionate sul fondo della vasca. Sistema particolarmente silenzioso, rilassante e distensivo, genera un massaggio efficace per rilassare la muscolatura.

/ The Airpool hydromassage system injects air into the water through dedicated nozzles positioned on the bottom of the tub. A particularly quiet, relaxing, and soothing system, it provides an effective massage to relax the muscles.

/ Le système d'hydromassage Airpool insuffle de l'air dans l'eau à travers des buses spécifiques placées au fond de la cuve. Particulièrement silencieux, relaxant et apaisant, il génère un massage efficace pour détendre la musculature.

/ El sistema de hidromasaje Airpool introduce aire en el agua a través de boquillas específicas situadas en el fondo de la bañera. Un sistema especialmente silencioso, relajante y distensivo, que genera un masaje eficaz para relajar la musculatura.

/ Das Airpool-Hydromassagesystem führt Luft über spezielle Düsen, die am Wannenboden positioniert sind, in das Wasser ein. Besonders leise, entspannend und wohltuend, erzeugt es eine wirksame Massage zur Lockerung der Muskulatur.

→

Elite, Thea Pool, Soreha, Oniris, Privè 103, Privè 206, Privè 306, Privè 405, Privè R07



Scopri il funzionamento Microsilik®

/ Discover how Microsilik® works

/ Découvrez le fonctionnement de Microsilik®

/ Descubra el funcionamiento de Microsilik®

/ Entdecken Sie die Funktionsweise von Microsilik®



Micro Silk

Sistema di idroterapia con microbolle di ossigeno che rendono l'acqua lattiginosa e avvolgono il corpo. Favorisce l'ossigenazione della pelle, stimola la produzione naturale di collagene, supporta il sistema immunitario e contribuisce all'igiene dell'acqua.

Utilizzo consigliato: circa 20 minuti per una pelle più liscia e uniforme.

/ A hydrotherapy system with oxygen microbubbles that make the water milky and envelop the body.

/ It promotes skin oxygenation, stimulates natural collagen production, supports the immune system, and contributes to water hygiene.

Recommended use: approximately 20 minutes for smoother, more even skin. / Système d'hydrothérapie à microbulles d'oxygène qui rendent l'eau lactescente et enveloppent le corps. Il favorise l'oxygénation de la peau, stimule la production naturelle de collagène, soutient le système immunitaire et contribue à l'hygiène de l'eau.

Utilisation recommandée : environ 20 minutes pour une peau plus lisse et plus uniforme.

/ Sistema de hidroterapia con microburbujas de oxígeno que vuelven el agua lechosa y envuelven el cuerpo. Favorece la oxigenación de la piel, estimula la producción natural de colágeno, apoya el sistema inmunitario y contribuye a la higiene del agua.

Uso recomendado: aproximadamente 20 minutos para una piel más lisa y uniforme. / Hydrotherapiesystem mit Sauerstoff-Mikrobläschen, die das Wasser milchig machen und den Körper umhüllen. Es fördert die Sauerstoffversorgung der Haut, regt die natürliche Kollagenproduktion an, unterstützt das Immunsystem und trägt zur Wasserhygiene bei.

Empfohlene Anwendung: etwa 20 Minuten für eine glattere und gleichmäßigere Haut.

Ethix
Soha
Hammam Plus

Albatros
01

Sauna & Hammam



Sauna Ethix
pag. 14



Sauna Soha
pag. 18



Hammam Plus
pag. 22



Ethix

Ethix è una sauna finlandese progettata nel centro Ricerca & Sviluppo di Albatros, essenziale e ricercata, alterna pareti legno abete con chiusura in vetro temperato. Si ispira allo stile nordico da cui proviene la cultura della Sauna finlandese. Perfetta all'interno di qualsiasi stile d'arredo e architettonico.

/

Ethix is a Finnish sauna designed in Albatros' Research & Development center, minimalist and refined, combining fir wood walls with a tempered glass enclosure. It is inspired by Nordic style, from which Finnish sauna culture originates. Perfect for any interior design and architectural style.

/

Ethix est un sauna finlandais conçu au centre Recherche & Développement d'Albatros, essentiel et raffiné, alternant des parois en bois de sapin avec une fermeture en verre trempé. Il s'inspire du style nordique, berceau de la culture du sauna finlandais. Parfait pour tout style d'aménagement intérieur et architectural.

/

Ethix es una sauna finlandesa diseñada en el centro de Investigación y Desarrollo de Albatros, esencial y refinada, que alterna paredes de madera de abeto con un cerramiento de vidrio templado. Se inspira en el estilo nórdico, del que proviene la cultura de la sauna finlandesa. Perfecta para cualquier estilo de interiorismo y arquitectura.

/

Ethix ist eine finnische Sauna, die im Forschungs- und Entwicklungszentrum von Albatros entworfen wurde – schlicht und elegant – und Tannenholzwände mit einer Umfassung aus gehärtetem Glas kombiniert. Sie ist vom nordischen Stil inspiriert, aus dem die Kultur der finnischen Sauna stammt. Perfekt für jeden Einrichtungs- und Architekturstil.

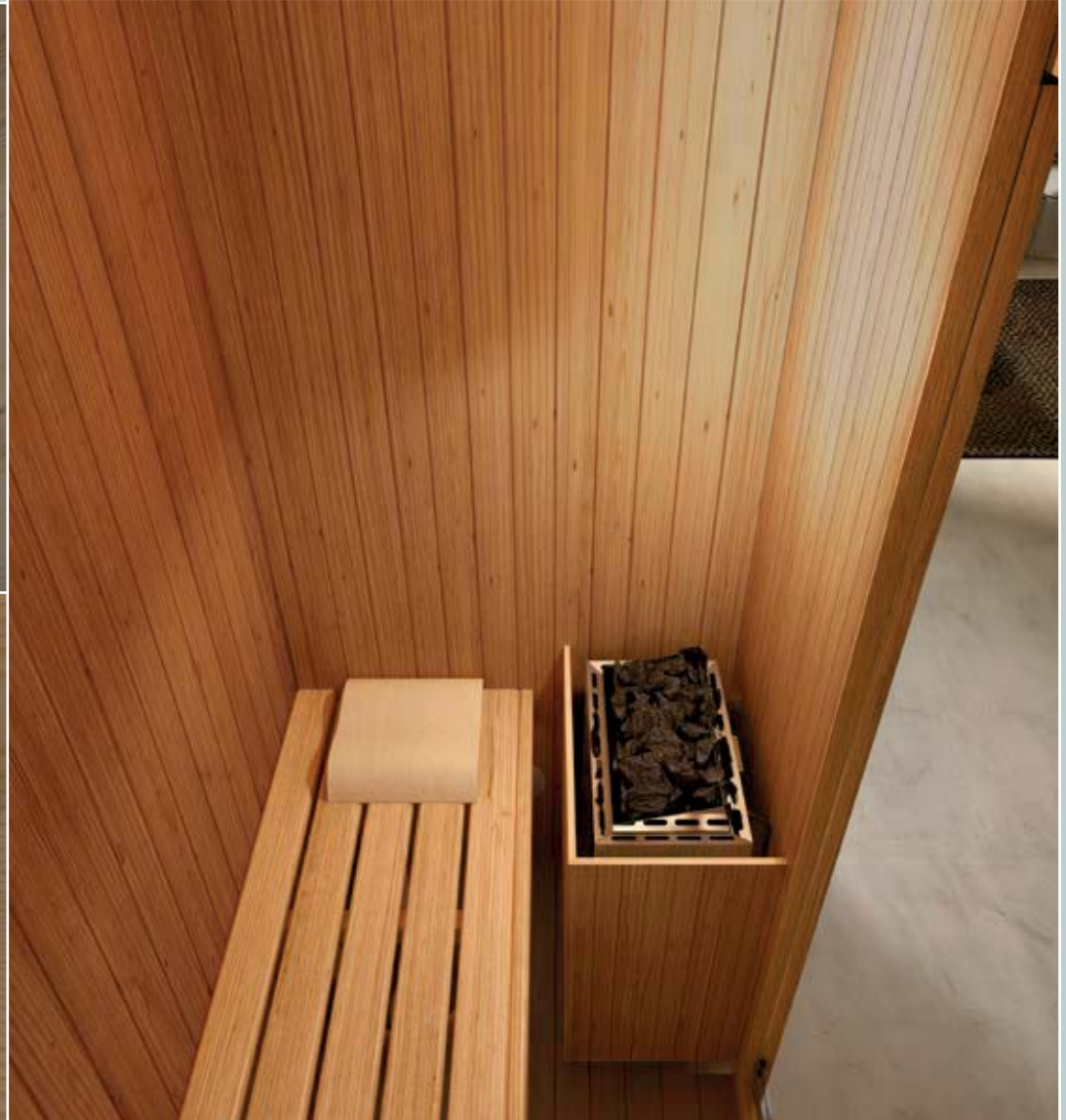

Ethix

DESIGN // ALBATROS R&D



1500 x 1000 - h 2100 mm
1900 x 1200 - h 2100 mm
1900 x 1500 - h 2100 mm

3,5 - 4,5 kW

6 mm

**Finiture / Finishes /
Finitions / Acabados /
Oberflächen**



Abete
Fir / Sapin
/ Abeto / Tanne



Trasparente
Transparent
Transparente



**Vetro
Retroverniciato
Nero**
/ Black back-
painted glass /
Verre vernis Noir /
Vidrio pintado negro
/ Glas hinterlackiert
Schwarz



**Vetro
Retroverniciato
Bianco**
/ White back-
painted glass /
Verre vernis Blanc
/ Vidrio pintado
blanco / Weiß
rückseitig lackiert

DOTAZIONI / FEATURES / ÉQUIPEMENTS / EQUIPAMIENTO / AUSSTATTUNG

STANDARD

	Alimentazione elettrica / power supply / alimentation électrique alimentación eléctrica / Energieversorgung	220 V / 380 V
	Maniglia / handle / poignée / manilla / Türgriff	100 mm
	Materiale panca / bench finish / finition banc / acabado de la banqueta / Bankmaterial	Ayous
	Illuminazione / Chromotherapy / Chromothérapie / Cromoterapia / Farbtherapie	LED
	Mastello e mestolo / Tub and ladle / Seau et louche / Cubo y cazo / Eimer und Kelle	✓
	Pedana / Platform / Plateforme / Plataforma / Plattform	✓
	Poggiatesta / Headrest / Appui-tête / Reposacabezas / Kopfstütze	✓
	Porta reversibile / Reversible door / Porte réversible / Puerta reversible / Wendetür	✓
	Clessidra / Hourglass / Sablier / Reloj de arena / Sanduhr	✓
	Stufa elettrica / Electric stove / Poêle électrique Estufa eléctrica / Elektroofen	✓
	Pietre laviche / Lava stones / Pierres de lave / Piedras volcánicas / Lavasteine	✓

DISEGNI TECNICI / TECHNICAL DRAWINGS / DESSINS TECHNIQUES
DIBUJOS TÉCNICOS / TECHNISCHE ZEICHNUNGEN

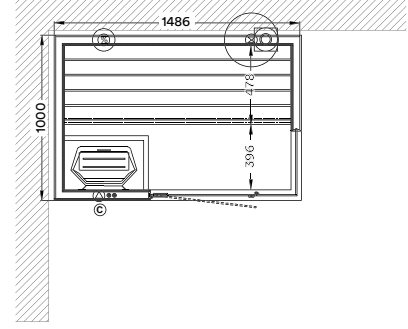
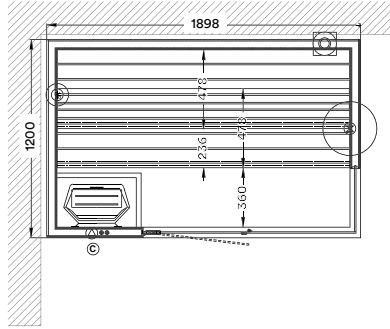
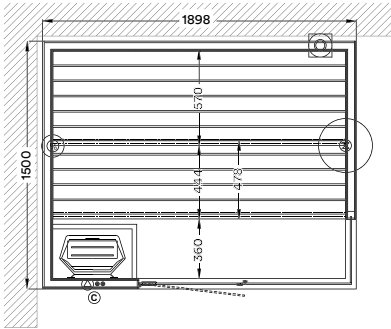

*S

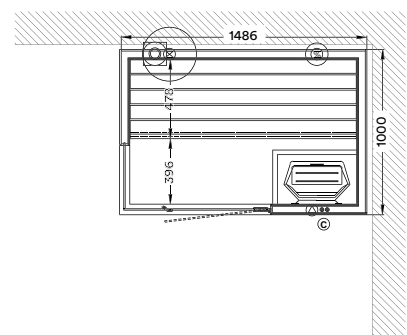
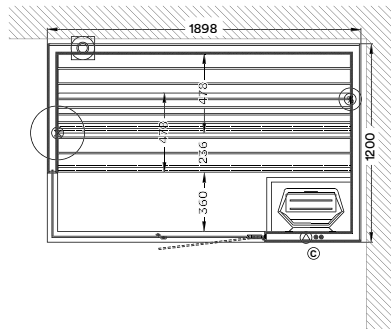
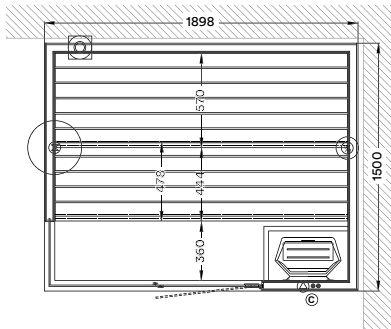

*D



SAUNA FINLANDESE / FINNISH SAUNA / SAUNA FINLANDAIS
SAUNA FINLANDESA / FINNISCHE SAUNA

		kW	 N° max		cod.	
Ethix Sauna	1500x1000	3	2	1	06ETN1*	13.300
Ethix Sauna	1900x1200	4,5	2	1	06ETN2*	15.000
Ethix Sauna	1900x1500	4,5	3	2	06ETN3*	15.600

*Sostituire con il verso D o S / Replace with D or S direction / Remplacer par le sense D ou S / Sustituir cpor el sentido D o S / Durch die Ausrichtung D oder S ersetzen

Optional

Cod.

Pulsanti di controllo luce e stufa aggiuntive in finitura cromo / Light and additional stove control buttons in chrome finish / Boutons de commande pour lumière et poêle supplémentaire en finition chrome / Botones de control de luz y estufa adicional en acabado cromo / Licht- und Zusatzofen-Bedientasten in Chromausführung	40S6F372	1.500
Pulsanti di controllo luce e stufa aggiuntive in finitura nero / Light and additional stove control buttons in black finish / Boutons de commande pour lumière et poêle supplémentaire en finition noire / Botones de control de luz y estufa adicional en acabado negro / Licht- und Zusatzofen-Bedientasten in schwarzer Ausführung	40S6F370	1.500
Musicoterapia / Music therapy / Musicothérapie / Musicoterapia / Musiktherapie	40S6F374	1.300
Cromoterapia / Chromotherapy / Chromothérapie / Cromoterapia / Chromotherapie	40S6F373	1.300
Pulsante di emergenza / Emergency button / Bouton d'urgence / Botón de emergencia / Not-Aus-Taste	40SZSOS	500
Poggiatesta in legno / Wooden headrest / Appui-tête en bois / Reposacabezas de madera / Holz-Kopfstütze	40S6F371	230
Vetro laterale retroverniciato BIANCO per versione in nicchia / Back-painted WHITE side glass for recess version / Verre latéral laqué BLANC pour version en niche / Vidrio lateral BLANCO retrobarnizado para versión en nicho / Rückseitig lackiertes SEITENGLAS in WEISS für Nischenversion	40ETN1B	200
Vetro laterale retroverniciato NERO per versione in nicchia / Back-painted BLACK side glass for recess version / Verre latéral laqué NOIR pour version en niche / Vidrio lateral NEGRO retrobarnizado para versión en nicho / Rückseitig lackiertes SEITENGLAS in SCHWARZ für Nischenversion	40ETN1N	200

Per le misure speciali intermedie considerare il prezzo della dimensione successiva più grande + 5%

Per le misure speciali superiori fattibilità e prezzo su richiesta

/ For intermediate special sizes consider the price of the next larger size + 5%

For special measures higher feasibility and price on request

/ Pour les tailles spéciales intermédiaires, prendre en compte le prix de hauteur standard plus large + 5%

Veillez nous consulter pour faisabilité et prix de dimensions supérieures

/ Para medidas especiales intermedias, considere el precio de la medida inmediatamente superior + 5%

Para las medidas especiales superiores factibilidad y precio a petición

/ Bei mittleren Sondergrößen gilt der Preis der nächstgrößeren Größe + 5%

Für höhere Sondermassnahmen Machbarkeit und Preis auf Anfrage



Soha

Soha nasce dalla ricerca dell'essenziale e dalla selezione dei legni resistenti e adatti alle alte temperature. Si inserisce nell'ambiente domestico con discrezione e personalità trasformando l'ambiente circostante in un ambiente wellness, dando spazio alla cultura del benessere.

/

Soha is born from the pursuit of essential design and the selection of durable woods suitable for high temperatures. It fits into the home environment with discretion and character, transforming the surrounding space into a wellness area and giving room to the culture of well-being.

/

Soha naît de la recherche de l'essentiel et de la sélection de bois résistants et adaptés aux hautes températures. Elle s'intègre dans l'environnement domestique avec discrétion et personnalité, transformant l'espace environnant en un lieu de bien-être et laissant place à la culture du bien-être.

/

Soha nace de la búsqueda de lo esencial y de la selección de maderas resistentes y aptas para altas temperaturas. Se integra en el entorno doméstico con discreción y personalidad, transformando el espacio que la rodea en un ambiente wellness y dando lugar a la cultura del bienestar.

/

Soha entsteht aus der Suche nach dem Wesentlichen und der Auswahl widerstandsfähiger, für hohe Temperaturen geeigneter Hölzer. Sie fügt sich mit Zurückhaltung und Charakter in den Wohnbereich ein, verwandelt den umgebenden Raum in eine Wellness-Umgebung und schafft Raum für eine Kultur des Wohlbefindens.



Soha

DESIGN // ALBATROS R&D



1500 x 1000 - h 2100 mm
1900 x 1200 - h 2100 mm
1900 x 1500 - h 2100 mm

3 - 4,5 kW

8 mm

**Finiture / Finishes /
Finitions / Acabados /
Oberflächen**



Abete
Fir / Sapin
/ Abeto / Tanne



Trasparente
Transparent
Transparente

DOTAZIONI / FEATURES / ÉQUIPEMENTS / EQUIPAMIENTO / AUSSTATTUNG	STANDARD
Alimentazione elettrica / power supply / alimentation électrique / alimentación eléctrica / Energieversorgung	220 V / 380 V
Maniglia / handle / poignée / manilla / Türgriff	580 mm
Materiale panca / bench finish / finition banc / acabado de la banqueta / Bankmaterial	Ayous
Illuminazione / Chromotherapy / Chromothérapie / Cromoterapia / Farbtherapie	LED
Mastello e mestolo / Tub and ladle / Seau et louche / Cubo y cazo / Eimer und Kelle	✓
Pedana / Platform / Plateforme / Plataforma / Plattform	✓
Poggiatesta / Headrest / Appui-tête / Reposacabezas / Kopfstütze	✓
Porta reversibile / Reversible door / Porte réversible / Puerta reversible / Wendetür	✓
Clessidra / Hourglass / Sablier / Reloj de arena / Sanduh	✓
Stufa elettrica con display / Electric stove with display / Poêle électrique avec écran / Estufa eléctrica con pantalla / Elektroofen mit Display	✓
Pietre laviche / Lava stones / Pierres de lave / Piedras volcánicas / Lavasteine	✓

DISEGNI TECNICI / TECHNICAL DRAWINGS / DESSINS TECHNIQUES
DIBUJOS TÉCNICOS / TECHNISCHE ZEICHNUNGEN

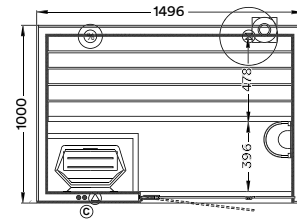
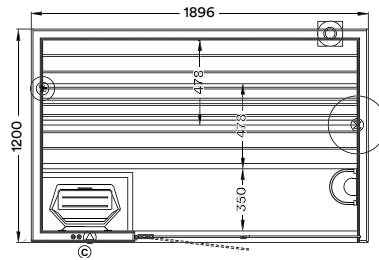
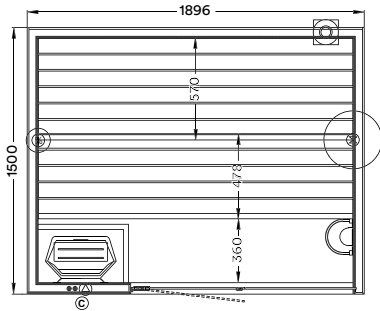

*S

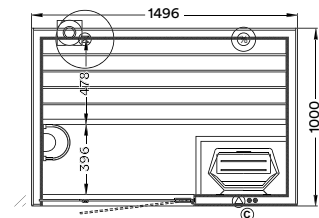
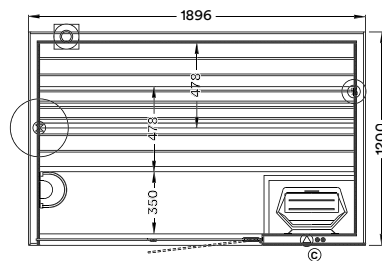
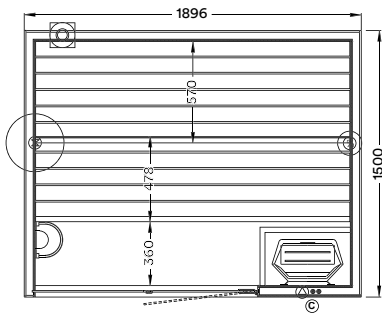

*D



SAUNA FINLANDESE / FINNISH SAUNA / SAUNA FINLANDAIS
SAUNA FINLANDESA / FINNISCHE SAUNA

		kW	 N° max		cod.	
Soha Sauna	1500x1000	3	2	1	06SON1*	12.300
Soha Sauna	1900x1200	4,5	2	1	06SON2*	14.000
Soha Sauna	1900x1500	4,5	3	2	06SON3*	14.600

*Sostituire con il verso D o S / Replace with D or S direction / Remplacer par le sense D ou S / Sustituir cpor el sentido D o S / Durch die Ausrichtung D oder S ersetzen

Optional
Cod.

Pulsanti di controllo luce e stufa aggiuntive in finitura cromo / Light and additional stove control buttons in chrome finish /
 Boutons de commande pour lumière et poêle supplémentaire en finition chrome /
 Botones de control de luz y estufa adicional en acabado cromo / Licht- und Zusatzofen-Bedientasten in Chromausführung

40S6F372
1.500

Pulsanti di controllo luce e stufa aggiuntive in finitura nero / Light and additional stove control buttons in black finish /
 Boutons de commande pour lumière et poêle supplémentaire en finition noire / Botones de control de luz y estufa adicional en acabado negro / Licht- und Zusatzofen-Bedientasten in schwarzer Ausführung

40S6F370
1.500

Musicoterapia / Music therapy / Musicothérapie / Musicoterapia / Musiktherapie

40S6F374
1.300

Cromoterapia / Chromotherapy / Chromothérapie / Cromoterapia / Chromotherapie

40S6F373
1.300

Poggiatesta in legno / Wooden headrest / Appui-tête en bois / Reposacabezas de madera / Holz-Kopfstütze

40S6F371
230

Per le misure speciali intermedie considerare il prezzo della dimensione successiva più grande + 5%

Per le misure speciali superiori fattibilità e prezzo su richiesta

/ For intermediate special sizes consider the price of the next larger size + 5%

For special measures higher feasibility and price on request

/ Pour les tailles spéciales intermédiaires, prendre en compte le prix de hauteur standard plus large + 5%

Veillez nous consulter pour faisabilité et prix de dimensions supérieures

/ Para medidas especiales intermedias, considere el precio de la medida inmediatamente superior + 5%

Para las medidas especiales superiores factibilidad y precio a petición

/ Bei mittleren Sondergrößen gilt der Preis der nächstgrößeren Größe + 5%

Für höhere Sondermassnahmen Machbarkeit und Preis auf Anfrage

Hammam Plus

DESIGN // CLAUDIO PAPA



510 x 625 x 106 mm

2,5 ÷ 6,5 kW

< 3,5/6,8 m³

**Finiture / Finishes /
Finitions / Acabados /
Oberflächen**

Elegant
tea for two (TT)Tortona
Natural (TN)

Kashmir (KS)



Graphite (GP)

DOTAZIONI / FEATURES / ÉQUIPEMENTS / EQUIPAMIENTO / AUSSTATTUNG

	Alimentazione elettrica / power supply / alimentation électrique alimentación eléctrica / Energieversorgung	220 (option 380)
	Illuminazione / Chromotherapy / Chromothérapie / Cromoterapia / Farbtherapie	LED
	Erogatore di aromaterapie / Aromatherapy dispenser Distributeur d'aromathérapie / Dispensador de aromaterapia / Aromatherapie-Spender	✓
	Sistema bluetooth / Bluetooth system / Système Bluetooth / Sistema Bluetooth / Bluetooth-System	✓
	Mensola porta oggetti / Shelf for objects / Étagère porte-objets / Estante para objetos / Ablagefach	✓
	Cover in solid surface / Solid surface cover / Couverture en solid surface Cubierta en solid surface / Abdeckung aus Solid Surface	✓
	Erogatore di vapore con portaessenze / Steam dispenser with essence holder Distributeur de vapeur avec porte-huiles essentielles / Dispensador de vapor con portaesencias / Dampferzeuger mit Duftölhalter	✓
	Appendino per accappatoio / Towel hook / Crochet pour peignoir Colgador para bata / Bademantelhaken	✓

	kW	m ³	Elegant Tea For Two	Tortona Natural	Kashmir	Graphite	
510×625	2,5	< 3,5	10HPTT0N	10HPTN0N	10HPKS0N	10HPGP0N	4.800
510×625	4,5	3,5/4,5	10HPTT1N	10HPTN1N	10HPKS1N	10HPGP1N	4.950
510×625	6,5	< 6,8	10HPTT2N	10HPTN2N	10HPKS2N	10HPGP2N	5.200

Optional**Cod.**

Touch Display / Touch display / Écran tactile / Pantalla táctil / Touch-Display

10HPDT02**700**

Lampada RGB per cromoterapia / RGB lamp for chromotherapy / Lampe RVB pour chromothérapie
Lámpara RGB para cromoterapia / RGB-Lampe für Chromotherapie

10HPLRGB**1.300**

Kit casse audio, sistema audio per diffusione del suono (conf. 2 pz)* / Audio speaker kit, sound diffusion system (set of 2 pcs)*
Kit haut-parleurs, système audio pour la diffusion du son (lot de 2 pcs)* / Kit de altavoces, sistema de audio para difusión del sonido (conf. 2 pzs)*
Lautsprecher-Kit, Audiosystem zur Schallverteilung (Set mit 2 Stk.)*

10HPKCAD**1.500**

***Solo in abbinamento con Bluetooth** / *Only in combination with Bluetooth / *Uniquement avec Bluetooth

***Solo en combinación con Bluetooth** / *Nur in Kombination mit Bluetooth

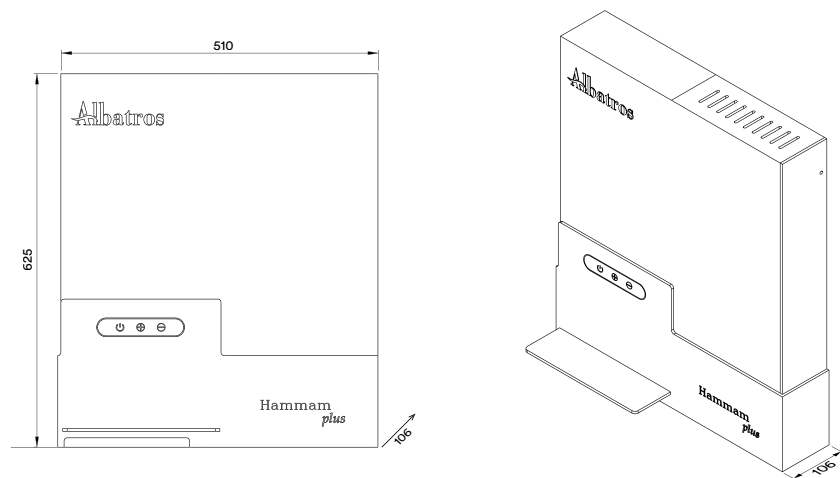

Su richiesta progettiamo e realizziamo la cellula HAMMAM completa, predisposta per l'installazione dei generatori di vapore, con sedute dedicate e adeguata coibentazione.

/

Upon request, we design and manufacture a complete HAMMAM cabin, prepared for steam generator installation, including dedicated seating and proper insulation.

/

Sur demande, nous concevons et réalisons une cellule HAMMAM complète, prévue pour l'installation des générateurs de vapeur, avec assises dédiées et isolation adaptée.

/

Bajo solicitud, diseñamos y fabricamos la célula HAMMAM completa, preparada para la instalación de generadores de vapor, con asientos específicos y aislamiento adecuado.

/

Auf Anfrage planen und realisieren wir eine komplette HAMMAM-Kabine, vorbereitet für die Installation von Dampfgeneratoren, mit integrierten Sitzflächen und geeigneter Isolierung.

Chiusura Hammam /enclosures

DESIGN // ALBATROS R&D



h.2000 mm



6 mm

Finiture / Finishes / Finitions / Acabados / Oberflächen



Trasparente
/ Transparent
/ Transparente



QQ

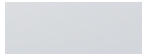

EE



ZZ



CC

DOTAZIONI / FEATURES / ÉQUIPEMENTS / EQUIPAMIENTO / AUSSTATTUNG

STANDARD



Protective glass

✓



Porta reversibile / Reversible door / Porte réversible / Puerta reversible / Wendetür

✓



Maniglia / handle / poignée / manilla / Türgriff

580 mm



Chiusura con guarnizione magnetica / Magnetic gasket closure / Fermeture avec joint magnétique / Cierre con junta magnética / Magnetische Dichtungsschließung

✓

mod	cod.		
PV	10HP**PV080	800	980
PVF	10HP**PVF130	1300	1.120
A1B+FB	10HP**AFB125	1200x500	1.500

**Sostituire con il codice della finitura profilo / Replace with the profile finishes code / Remplacer par le code des finitions du profil Remplacer par le code des finitions du profil / Sustituir con el código de los acabados del perfil / Durch den Code der Profloberflächen ersetzen

PV

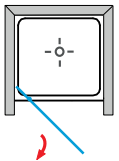
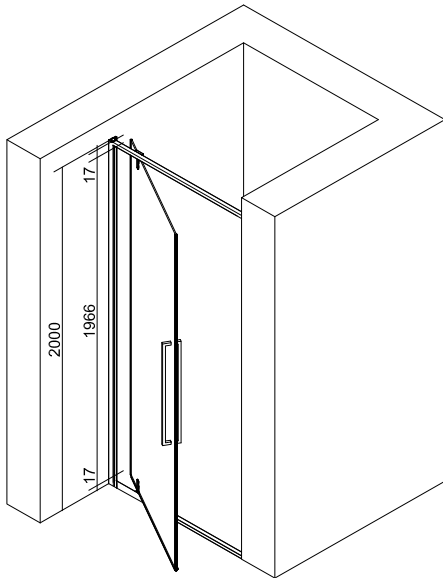

PVF

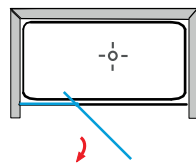
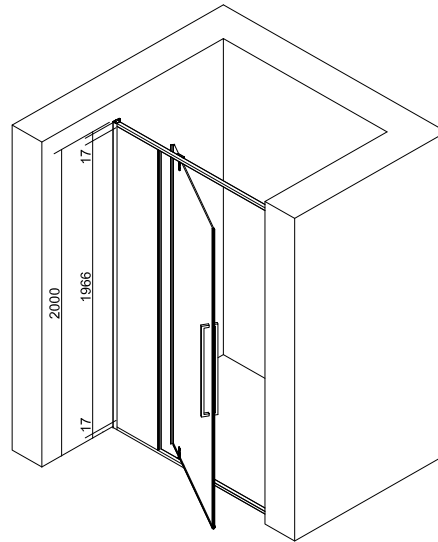

AB1+FB

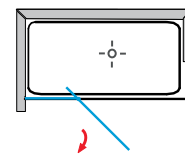
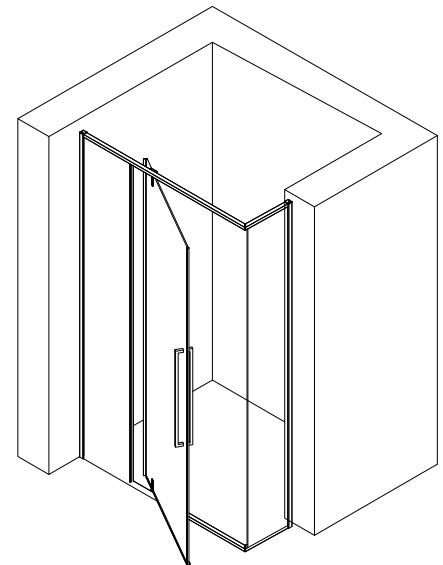

Modula 210x190 h 95

Kellia 160x170 h 55

Syraka 141x169 h 55

Albatros

02

Minipiscine Secret System

SECRET SYSTEM SPA



Modula
pag. 28



Kellia
pag. 30



Syraka
pag. 32

Modula Pool

DESIGN // CLAUDIO PAPA

Incassata / Built-in / Encastrable /
Emportada / Einbau



210 x 190 - h 95 cm

1200 lt | max

600 kg

x4
 x2
n° max

Finiture / Finishes /
Finitions / Acabados /
Oberflächen



Solid Surface
White

Pannelli Panels /
Panneaux / Paneles /
Pannele Solid Surface

White

RAL

DOTAZIONI / FEATURES / ÉQUIPEMENTS / EQUIPAMIENTO / AUSSTATTUNG	STANDARD	PLUS
Whirlpool Jets	24	24
Airpool Jets	-	36
Bocchette / Nozzles / Buses / Boquillas / Düsen	SecretJets	SecretJets
Disinfezione con Sistema UV / UV Disinfection System / Système de désinfection UV / Sistema de desinfección UV / UV-Desinfektionssystem	-	✓
Cromoterapia / Chromotherapy / Chromothérapie / Cromoterapia / Farbtherapie	-	✓
Riscaldatore 3Kw / 3kW Heater / Chauffage 3kW / Calentador de 3kW / 3kW-Heizung	✓	✓
Pompe / Pumps / Pompes / Bombas / Pumpen	1 2speed	1
Pompa Silence Spa / Silence Spa pump / Pompe Silence Spa / Bomba Silence Spa / Silence Spa Pumpe	-	1
Scarico semi-automatico / Semi-automatic Drain / Vidange semi-automatique / Drenaje semiautomático / Halbautomatischer Ablauf	✓	✓
Carico automatico / Automatic filling system / Système de remplissage automatique / Sistema de llenado automático / Automatisches Befüllsystem	✓	✓
Vasca di compenso / Réservoir de compensation / Depósito de compensación / Ausgleichsbehälter	✓	✓
Sensore di livello / Level sensor / Capteur de niveau / Sensor de nivel / Niveausensor	✓	✓
Overflow	✓	✓
Cascata / Waterfall / Cascade / Cascada / Wasserfall	-	✓
Luce Perimetrale / Perimeter light / Lumière périmétrique / Luz perimetral / Umfangsbeleuchtung	-	✓
Display Touch	✓	✓

GREEN PLUS



ENERGY SAVING



SILENCE SPA



RECYCLABLE



ECO MATERIAL

	Bianco Solid	Greytek
MODULA POOL STANDARD	04MPEBSTBS	43.300
MODULA POOL PLUS	04MPXBPLBS	49.600
Copertura termica Thermal Cover / Couverture thermique / Cubierta térmica / Thermoabdeckung	40SYCT00	2.500

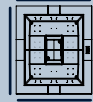

Pannelli / Panels / Panneaux / Paneles / Paneele

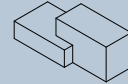

Scaletta / Access Ladder / Échelle d'accès / Escalera de acceso / Einstiegsleiter

Bianco Solid	40MPFRBS	4.500	40MPSC00	2.100
RAL	40MPFR**	5.900	-	

**Il codice verrà comunicato dopo la scelta del colore / The code will be provided after the color selection / Le code sera communiqué après le choix de la couleur / El código se comunicará después de la elección del color / Der Code wird nach der Farbauswahl mitgeteilt

Optional	Codice	
Scambiatore di Calore / Heat exchanger / Échangeur de chaleur / Intercambiador de calor / Wärmetauscher	40SDC00	Su richiesta / On request / Sur demande / Bajo solicitud / Auf Anfrage
Poggiatesta / Headrest / Appuie-tête / Reposacabezas / Kopfstütze	40MPCS00	280
Kit Mantenimento Spa / Spa Maintenance Kit / Kit d'entretien Spa / Kit de mantenimiento Spa / Spa-Pflegekit	40KITMAN	320
Kit Pulizia Spa / Spa Cleaning Kit / Kit de nettoyage Spa / Kit de limpieza Spa / Spa-Reinigungsset	40KITPUL	120



Scopri i nostri sistemi di idromassaggio
/ Discover our hydromassage systems
/ Découvrez nos systèmes de hydromassage
/ Descubre nuestros sistemas de hidromasaje
/ Entdecken Sie unsere Hydromassage-Systeme



Scopri il funzionamento Secret System
/ Discover how Secret System works
/ Découvrez le fonctionnement de Secret System
/ Descubra el funcionamiento de Secret System
/ Entdecken Sie die Funktionsweise von Secret System

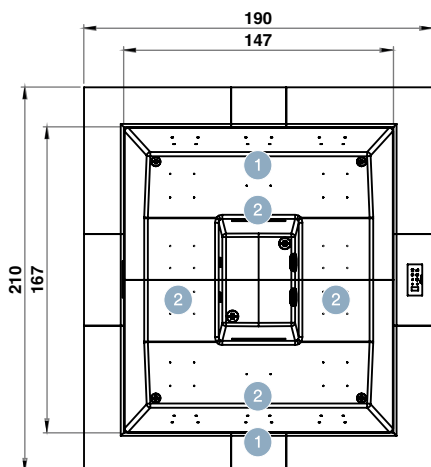

1 SecretJets Whirpool

2 SecretJets Airpool

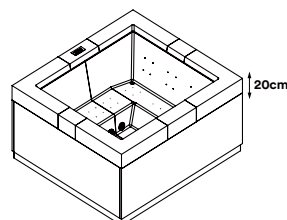

MASSAGGI /
Massages / Massages /
Masajes / Massagen

Flusso Vitale

Sollievo profondo

Per le misure esterne considerare una tolleranza di ± 5 mm / For the external dimensions, allow a tolerance of ± 5 mm / Pour les dimensions extérieures, prévoir une tolérance de ± 5 mm / Para las medidas exteriores, considerar una tolerancia de ± 5 mm / Für die Außenmaße ist eine Toleranz von ± 5 mm zu berücksichtigen

Kellia Pool

DESIGN // CLAUDIO PAPA



 160 x 170 - h 55 cm

 280 lt | max

 250 kg

 x2 | n° max

Finiture / Finishes / Finitions / Acabados / Oberflächen

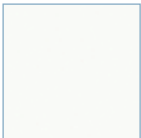

Solid Surface White

Pannelli Panels / Panneaux / Paneles / Panele Solid Surface

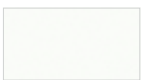











White



RAL

DOTAZIONI / FEATURES / ÉQUIPEMENTS / EQUIPAMIENTO / AUSSTATTUNG

PLUS

 Whirlpool Jets	8
 Airpool Jets	24
 Bocchette / Nozzles / Buses / Boquillas / Düsen	SecretJets
 Disinfezione con Sistema UV / UV Disinfection System / Système de désinfection UV / Sistema de desinfección UV / UV-Desinfektionssystem	✓
 Cromoterapia / Chromotherapy / Chromothérapie / Cromoterapia / Farbtherapie	✓
 Riscaldatore 1,3Kw / 1,3kW Heater / Chauffage 1,3kW / Calentador de 1,3kW / 1,3kW-Heizung	✓
 Pompe / Pumps / Pompes / Bombas / Pumpen	1
 Pompa Silence Spa / Silence Spa pump / Pompe Silence Spa / Bomba Silence Spa / Silence Spa Pumpe	1
 Carico-scarico semi-automatico / Semi-automatic filling and draining system / Système de remplissage et vidage / Sistema de llenado y vaciado semiautomático / Halbautomatisches Befüll- und Entleerungssystem	✓
 Filtro a cotone / Cotton filter / Filtre en coton / Filtro de algodón / Baumwolfilter	✓
 Display Touch	✓

GREEN PLUS



ENERGY SAVING



SILENCE SPA



RECYCLABLE



ECO MATERIAL

Bianco Solid Greytek

KELLIA POOL

04KE1BBS 18.600

Copertura termica Thermal Cover / Couverture thermique / Cubierta térmica / Thermoabdeckung

40SYCT00 2.500



Pannelli / Panels / Panneaux / Paneles / Paneele

Bianco Solid	04KE1NBS	1.000	04KE1ABS	1.900	04KE1PBS	2.800	04KE1FBS	3.700
RAL a scelta	04KE1N**	1.800	04KE1A**	3.500	04KE1P**	5.200	04KE1F**	6.900

**Il codice verrà comunicato dopo la scelta del colore / The code will be provided after the color selection / Le code sera communiqué après le choix de la couleur / El código se comunicará después de la elección del color / Der Code wird nach der Farbauswahl mitgeteilt

Optional	Codice		
Rubinetteria con cascata / Tapware with cascade / Robinet cascade / Grifo de cascada / Wasserfallhahn	Cromo	40RUBCRO	538
	Acciaio Inox	40RUBISO	885
Kit Mantenimento Spa / Spa Maintenance Kit / Kit d'entretien Spa / Kit de mantenimiento Spa / Spa-Pflegekit		40KITMAN	320
Kit Pulizia Spa / Spa Cleaning Kit / Kit de nettoyage Spa / Kit de limpieza Spa / Spa-Reinigungsset		40KITPUL	120



Scopri i nostri sistemi di idromassaggio / Discover our hydromassage systems / Découvrez nos systèmes de hydromassage / Descubre nuestros sistemas de hidromasaje / Entdecken Sie unsere Hydromassage-Systeme



Scopri il funzionamento Secret System / Discover how Secret System works / Découvrez le fonctionnement de Secret System / Descubra el funcionamiento de Secret System / Entdecken Sie die Funktionsweise von Secret System

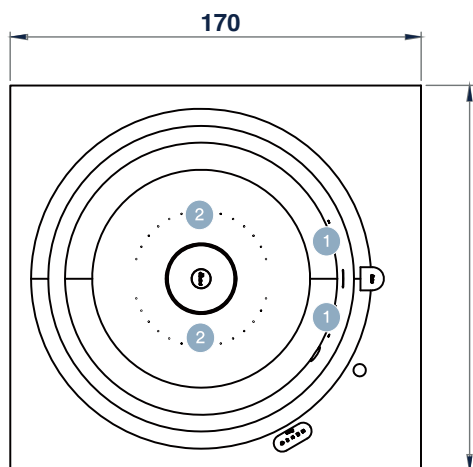

1 SecretJets Whirlpool

2 SecretJets Airpool

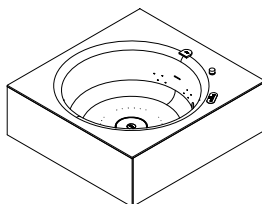

MASSAGGI /
Massages / Massages /
Masajes / Massagen

Sollievo profondo

Per le misure esterne considerare una tolleranza di ± 5 mm / For the external dimensions, allow a tolerance of ± 5 mm / Pour les dimensions extérieures, prévoir une tolérance de ± 5 mm / Para las medidas exteriores, considerar una tolerancia de ± 5 mm / Für die Außenmaße ist eine Toleranz von ± 5 mm zu berücksichtigen

Syraka Pool

DESIGN // CLAUDIO PAPA



 141 x 169 - h 55 cm

 280 lt | max

 180 kg

 x2 | n° max

Finiture / Finishes / Finitions / Acabados / Oberflächen

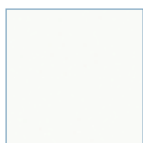

Solid Surface White

Pannelli Panels / Panneaux / Paneles / Panele Solid Surface

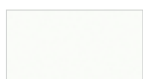

White



RAL

DOTAZIONI / FEATURES / ÉQUIPEMENTS / EQUIPAMIENTO / AUSSTATTUNG

PLUS

 Whirlpool Jets	8
 Airpool Jets	24
 Bocchette / Nozzles / Buses / Boquillas / Düsen	SecretJets
 Cromoterapia / Chromotherapy / Chromothérapie / Cromoterapia / Farbtherapie	✓
 Riscaldatore 1,3Kw / 1,3kW Heater / Chauffage 1,3kW / Calentador de 1,3kW / 1,3kW-Heizung	✓
 Pompe / Pumps / Pompes / Bombas / Pumpen	1
 Pompa Silence Spa / Silence Spa pump / Pompe Silence Spa / Bomba Silence Spa / Silence Spa Pumpe	1
 Carico-scarico semi-automatico / Semi-automatic filling and draining system / Système de remplissage et vidage / Sistema de llenado y vaciado semiautomático / Halbautomatisches Befüll-und Entleerungssystem	✓
 Filtro a cotone / Cotton filter / Filtre en coton / Filtro de algodón / Baumwolfilter	✓
 Display Touch	✓

GREEN PLUS



ENERGY SAVING



SILENCE SPA



RECYCLABLE



ECO MATERIAL

Bianco Solid Greytek

SYRAKA POOL TOTAL WHITE

04SY1BBS

25.000

SYRAKA POOL RAL

Colorazione solo esterna / External finish only / Coloration extérieure uniquement / Coloración solo externa / Farbgebung nur außen

04SY1R**

26.600

Copertura termica Thermal Cover / Couverture thermique / Cubierta térmica / Thermoabdeckung

40SYCT00

2.400

**Il codice verrà comunicato dopo la scelta del colore / The code will be provided after the color selection / Le code sera communiqué après le choix de la couleur / El código se comunicará después de la elección del color / Der Code wird nach der Farbauswahl mitgeteilt

Optional	Codice	
Rubineria con cascata / Tapware with cascade / Robinet cascade / Grifo de cascada / Wasserfallhahn	Cromo	40RUBCRO 538
	Acciaio Inox	40RUBISO 885
Kit Mantenimento Spa / Spa Maintenance Kit / Kit d'entretien Spa / Kit de mantenimiento Spa / Spa-Pflegekit		40KITMAN 320
Kit Pulizia Spa / Spa Cleaning Kit / Kit de nettoyage Spa / Kit de limpieza Spa / Spa-Reinigungsset		40KITPUL 120



Scopri i nostri sistemi di idromassaggio
 / Discover our hydromassage systems
 / Découvrez nos systèmes de hydromassage
 / Descubre nuestros sistemas de hidromasaje
 / Entdecken Sie unsere Hydromassage-Systeme



Scopri il funzionamento Secret System
 / Discover how Secret System works
 / Découvrez le fonctionnement de Secret System
 / Descubra el funcionamiento de Secret System
 / Entdecken Sie die Funktionsweise von Secret System

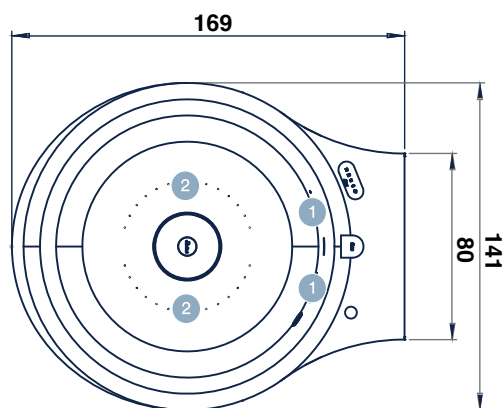

1 SecretJets Whirpool

2 SecretJets Airpool

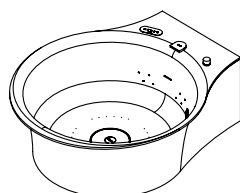

MASSAGGI /
 Massages / Massages /
 Masajes / Massagen

 **Sollievo profondo**

Thea 229x229 h 86
Soreha 228x188 h 86
Oniris 228x188 h 86
Miris 200x150 h 67
Elite 188x188 h 94
Marvelia 190x120 h 61
Soreha Mini 180x180 h 57
Aster 140x140 h 60

Albatros

03

Minipiscine Glamour

GLAMOUR SPA



Thea
pag. 36



Soreha
pag. 38



Oniris
pag. 40



Miris
pag. 42



Elite
pag. 44



Marvelia
pag. 46



Soreha Mini
pag. 48



Aster
pag. 50

Thea Pool

DESIGN // ALBATROS R&D



229 x 229 - h 86 cm

1000 lt | max

350 kg

x1
 x4
n° max

Finiture / Finishes / Finitions / Acabados / Oberflächen

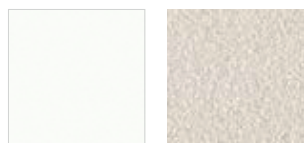

Molded White **Molded Madreperla**

Pannelli Panels / Panneaux / Paneles / Panele B-PLUS



Elegant Tea For Two (TT)

Tortona Natural (TN)

Graphite (GP)

Kashmir (KS)

DOTAZIONI / FEATURES / ÉQUIPEMENTS / EQUIPAMIENTO / AUSSTATTUNG **STANDARD** **PLUS**

Whirlpool Jets	28	28
Airpool Jets	-	22
Bocchette / Nozzles / Buses / Boquillas / Düsen	FilJet	FilJet
Disinfezione con Sistema UV / UV Disinfection System / Système de désinfection UV / Sistema de desinfección UV / UV-Desinfektionssystem	-	✓
Cromoterapia / Chromotherapy / Chromothérapie / Cromoterapia / Farbtherapie	-	✓
Riscaldatore 3Kw / 3kW Heater / Chauffage 3kW / Calentador de 3kW / 3kW-Heizung	✓	✓
Pompe / Pumps / Pompes / Bombas / Pumpen	1 2speed	1
Pompa Silence Spa / Silence Spa pump / Pompe Silence Spa / Bomba Silence Spa / Silence Spa Pumpe	-	1
Carico-scarico semi-automatico / Semi-automatic filling and draining system / Système de remplissage et vidage / Sistema de llenado y vaciado semiautomático / Halbautomatisches Befüll- und Entleerungssystem	✓	✓
Filtro a cartuccia / Cartridge Filter / Filtre à cartouche / Filtro de cartucho / Kartuschenfilter	✓	✓
Skimmer a parete / Wall-mounted skimmer / Skimmer mural / Skimmer de pared / Wandskimmer	✓	✓
Touch Display	✓	✓

GREEN PLUS



ENERGY SAVING

MICROBAN

SILENCE SPA

COMMAND SPA

	Molded White	Greytek
THEA POOL STANDARD	04TH18STBN	12.900
THEA POOL PLUS	04TH18PLBN	15.700
Copertura termica <i>Thermal Cover / Couverture thermique / Cubierta térmica / Thermoabdeckung</i>		40THCT00 1.600



Pannelli / Panels / Panneaux /
Paneles / Panele + 3 cm

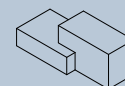

Scaletta / Access Ladder /
Échelle d'accès / Escalera de
acceso / Einstiegsleiter

Elegant Tea For Two (TT)	40THPRTT	3.600	40XXSCTT	2.000
Tortona Natural (TN)	40THPRTN	3.600	40XXSCTN	2.000
Graphite (GP)	40THPRGP	3.600	40XXSCGP	2.000
Kashmir (KS)	40THPRKS	3.600	40XXSCKS	2.000

Optional	Codice	
Poggiatesta / Headrest / Appuie-tête / Reposacabezas / Kopfstütze	40THCS00	270
Micro Silk	40MCSK00	2.850
Scambiatore di Calore / Heat exchanger / Échangeur de chaleur / Intercambiador de calor / Wärmetauscher	40SDC00	Su richiesta / On request / Sur demande / Bajo solicitud / Auf Anfrage
Command Spa	40CMS00	600
Filtro a sabbia esterno / External sand filter / Filtre à sable externe / Filtro de arena externo / Externer Sandfilter	40FILS01	1.700
Kit Mantenimento Spa / Spa Maintenance Kit / Kit d'entretien Spa / Kit de mantenimiento Spa / Spa-Pflegekit	40KITMAN	320
Kit Pulizia Spa / Spa Cleaning Kit / Kit de nettoyage Spa / Kit de limpieza Spa / Spa-Reinigungsset	40KITPUL	120



Scopri i nostri sistemi di idromassaggio
/ Discover our hydromassage systems
/ Découvrez nos systèmes de hydromassage
/ Descubre nuestros sistemas de hidromasaje
/ Entdecken Sie unsere Hydromassage-Systeme



Scopri il funzionamento Microsilik®
/ Discover how Microsilik® works
/ Découvrez le fonctionnement de Microsilik®
/ Descubra el funcionamiento de Microsilik®
/ Entdecken Sie die Funktionsweise von Microsilik®

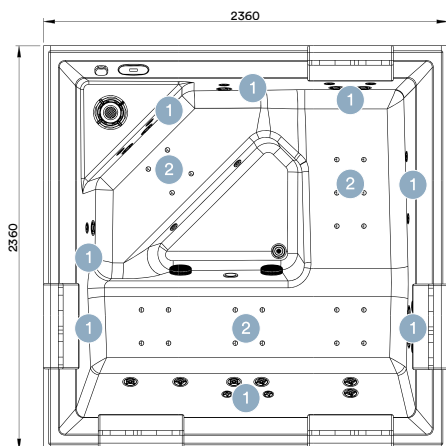

1 Whirlpool

2 Airpool

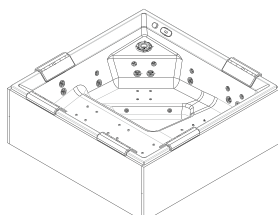

MASSAGGI /
Massages / Massages /
Masajes / Massagen

Abbraccio d'acqua

Armonia Totale

Flusso Vitale

Respiro profondo

Sostegno Avvolgente

2 Solo Plus / Plus only / Version Plus
uniquement / Solo Plus / Nur Plus

Per le misure esterne considerare una tolleranza di ± 5 mm
For the external dimensions, allow a tolerance of ± 5 mm
Pour les dimensions extérieures, prévoir une tolérance de ± 5 mm
Para las medidas exteriores, considerar una tolerancia de ± 5 mm
Für die Außenmaße ist eine Toleranz von ± 5 mm zu berücksichtigen

Soreha Pool

DESIGN // ALBATROS R&D

Standard-Plus

Incassata / Built-in / Encastrable /
Emportada / Einbau



 228 x 188 - h 86 cm

 900 lt | max

 270 kg

 x3
 x1
n° max

**Finiture / Finishes /
Finitions / Acabados /
Oberflächen**

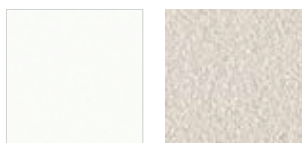

Molded White **Molded Madreperla**

**Pannelli Panels /
Panneaux / Paneles /
Paneele B-PLUS**



**Elegant Tea For
Two (TT)**



**Tortona
Natural (TN)**















Graphite (GP)



Kashmir (KS)

DOTAZIONI / FEATURES / ÉQUIPEMENTS / EQUIPAMIENTO / AUSSTATTUNG

	STANDARD	PLUS
 Whirlpool Jets	28	28
 Airpool Jets	-	12
 Bocchette / Nozzles / Buses / Boquillas / Düsen	FilJet	FilJet
 Disinfezione con Sistema UV / UV Disinfection System / Système de désinfection UV / Sistema de desinfección UV / UV-Desinfektionssystem	-	✓
 Cromoterapia / Chromotherapy / Chromothérapie / Cromoterapia / Farbtherapie	-	✓
 Riscaldatore 3Kw / 3kW Heater / Chauffage 3kW / Calentador de 3kW / 3kW-Heizung	✓	✓
 Pompe / Pumps / Pompes / Bombas / Pumpen	1 2speed	1
 Pompa Silence Spa / Silence Spa pump / Pompe Silence Spa / Bomba Silence Spa / Silence Spa Pumpe	-	1
 Carico-scarico semi-automatico / Semi-automatic filling and draining system / Système de remplissage et vidage / Sistema de llenado y vaciado semiautomático / Halbautomatisches Befüll-und Entleerungssystem	✓	✓
 Filtro a cartuccia / Cartridge Filter / Filtre à cartouche / Filtro de cartucho / Kartuschenfilter	✓	✓
 Skimmer a parete / Wall-mounted skimmer / Skimmer mural / Skimmer de pared / Wandskimmer	-	1
 Materassino / Mat / Matelas / Colchoneta / Matte	✓	✓
 Touch Display	✓	✓

GREEN PLUS



ENERGY SAVING



MICROBAN



SILENCE SPA



COMMAND SPA

Molded White

Molded Madreperla

Greytek

SOREHA POOL STANDARD

04FOBF01

11.400

04FOMF01

11.700

SOREHA POOL PLUS

04SO28BN

15.100

04SO28PN

15.400

Copertura termica Thermal Cover / Couverture thermique / Cubierta térmica / Thermabdeckung

40SOCT00

1.500

Optional



Pannelli / Panels / Panneaux / Paneles / Panelee + 3 cm

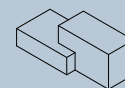

Scaletta / Access Ladder / Échelle d'accès / Escalera de acceso / Einstiegsleiter

Elegant Tea For Two (TT)

40SOPRTT

3.500

40XXSCTT

2.000

Tortona Natural (TN)

40SOPRTN

3.500

40XXSCTN

2.000

Graphite (GP)

40SOPRGP

3.500

40XXSCGP

2.000

Kashmir (KS)

40SOPRKS

3.500

40XXSCKS

2.000

Optional

Codice

Poggiatesta / Headrest / Appuie-tête / Reposacabezas / Kopfstütze

40SOCS00

270

Micro Silk

40MCSK00

2.850

Scambiatore di Calore / Heat exchanger / Échangeur de chaleur / Intercambiador de calor / Wärmetauscher

40SDC00

Su richiesta / On request / Sur demande / Bajo solicitud / Auf Anfrage

Command Spa

40CMS00

600

Filtro a sabbia / Sand filter / Filtre à sable / Filtro de arena / Sandfilter

40FILS02

1.400

Kit Mantenimento Spa / Spa Maintenance Kit / Kit d'entretien Spa / Kit de mantenimiento Spa / Spa-Pflegekit

40KITMAN

320

Kit Pulizia Spa / Spa Cleaning Kit / Kit de nettoyage Spa / Kit de limpieza Spa / Spa-Reinigungsset

40KITPUL

120



Scopri i nostri sistemi di idromassaggio / Discover our hydromassage systems / Découvrez nos systèmes de hydromassage / Descubre nuestros sistemas de hidromasaje / Entdecken Sie unsere Hydromassage-Systeme



Scopri il funzionamento Microsilik® / Discover how Microsilik® works / Découvrez le fonctionnement de Microsilik® / Descubra el funcionamiento de Microsilik® / Entdecken Sie die Funktionsweise von Microsilik®

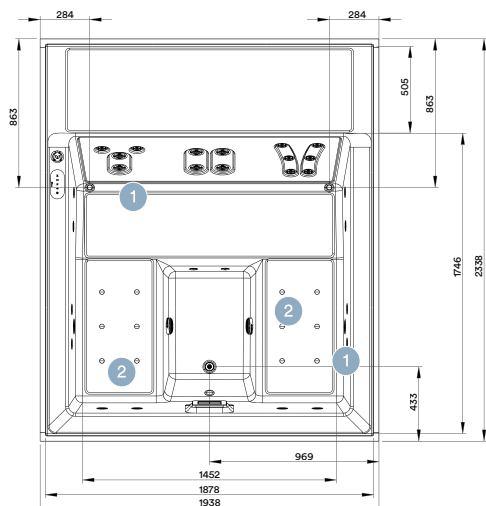

1 Whirlpool

2 Airpool

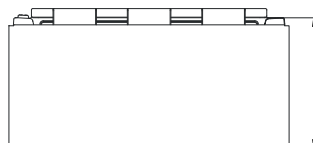

MASSAGGI / Massages / Massages / Masajes / Massagen

- Respiro profondo
- Onda di Benessere
- Equilibrio
- Ali di Energia
- Radici Forti

2 Solo Plus / Plus only / Version Plus uniquement / Solo Plus / Nur Plus

Per le misure esterne considerare una tolleranza di ± 5 mm
For the external dimensions, allow a tolerance of ± 5 mm
Pour les dimensions extérieures, prévoir une tolérance de ± 5 mm
Para las medidas exteriores, considerar una tolerancia de ± 5 mm
Für die Außenmaße ist eine Toleranz von ± 5 mm zu berücksichtigen

Oniris Pool

DESIGN // ALBATROS R&D



 228 x 188 - h 86 cm

 900 lt | max

 270 kg

 x4
 x2
n° max

Finiture / Finishes / Finitions / Acabados / Oberflächen

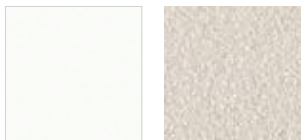

Molded White **Molded Madreperla**

Pannelli Panels / Panneaux / Paneles / Panele B-PLUS



Elegant Tea For Two (TT)















Tortona Natural (TN)



Graphite (GP)



Kashmir (KS)

DOTAZIONI / FEATURES / ÉQUIPEMENTS / EQUIPAMIENTO / AUSSTATTUNG	STANDARD	PLUS
 Whirlpool Jets	28	28
 Airpool Jets	-	12
 Bocchette / Nozzles / Buses / Boquillas / Düsen	FilJet	FilJet
 Disinfezione con Sistema UV / UV Disinfection System / Système de désinfection UV / Sistema de desinfección UV / UV-Desinfektionssystem	-	✓
 Cromoterapia / Chromotherapy / Chromothérapie / Cromoterapia / Farbtherapie	-	✓
 Riscaldatore 3Kw / 3kW Heater / Chauffage 3kW / Calentador de 3kW / 3kW-Heizung	✓	✓
 Pompe / Pumps / Pompes / Bombas / Pumpen	1 2speed	1
 Pompa Silence Spa / Silence Spa pump / Pompe Silence Spa / Bomba Silence Spa / Silence Spa Pumpe	-	1
 Carico-scarico semi-automatico / Semi-automatic filling and draining system / Système de remplissage et vidage / Sistema de llenado y vaciado semiautomático / Halbautomatisches Befüll- und Entleerungssystem	✓	✓
 Filtro a cartuccia / Cartridge Filter / Filtre à cartouche / Filtro de cartucho / Kartuschenfilter	✓	✓
 Skimmer a parete / Wall-mounted skimmer / Skimmer mural / Skimmer de pared / Wandskimmer	✓	✓
 Touch Display	✓	✓

GREEN PLUS



ENERGY SAVING



MICROBAN



SILENCE SPA



COMMAND SPA

	Molded White		Molded Madreperla		Greytek
ONIRIS POOL STANDARD	04ON22STBN	10.700	04ON22STMP	11.000	
ONIRIS POOL PLUS	04ON22PLBN	12.600	04ON22PLMP	12.900	
Copertura termica Thermal Cover / Couverture thermique / Cubierta térmica / Thermoabdeckung					04ONCT00 1.600

Optional



Pannelli / Panels / Panneaux /
Paneles / Paneele + 0 cm

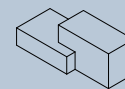

Scaletta / Access Ladder /
Échelle d'accès / Escalera de
acceso / Einstiegsleiter

Elegant Tea For Two (TT)	40ONPRTT	2.800	40XXSCTT	2.000
Tortona Natural (TN)	40ONPRTN	2.800	40XXSCTN	2.000
Graphite (GP)	40ONPRGP	2.800	40XXSCGP	2.000
Kashmir (KS)	40ONPRKS	2.800	40XXSCKS	2.000

Optional	Codice	
Poggiatesta / Headrest / Appuie-tête / Reposacabezas / Kopfstütze	40ONCS00	250
Micro Silk	40MCSK00	2.850
Scambiatore di Calore / Heat exchanger / Échangeur de chaleur / Intercambiador de calor / Wärmetauscher	40SDC00	Su richiesta / On request / Sur demande / Bajo solicitud / Auf Anfrage
Command Spa	40CMS00	600
Filtro a sabbia esterno / External sand filter / Filtre à sable externe / Filtro de arena externo / Externer Sandfilter	40FILS01	1.700
Kit Hot & Ice	40HICE0	3.900
Kit Mantenimento Spa / Spa Maintenance Kit / Kit d'entretien Spa / Kit de mantenimiento Spa / Spa-Pflegekit	40KITMAN	320
Kit Pulizia Spa / Spa Cleaning Kit / Kit de nettoyage Spa / Kit de limpieza Spa / Spa-Reinigungsset	40KITPUL	120



Scopri i nostri sistemi di idromassaggio
/ Discover our hydromassage systems
/ Découvrez nos systèmes de hydromassage
/ Descubre nuestros sistemas de hidromasaje
/ Entdecken Sie unsere Hydromassage-Systeme



Scopri il funzionamento Microsilik®
/ Discover how Microsilik® works
/ Découvrez le fonctionnement de Microsilik®
/ Descubra el funcionamiento de Microsilik®
/ Entdecken Sie die Funktionsweise von Microsilik®

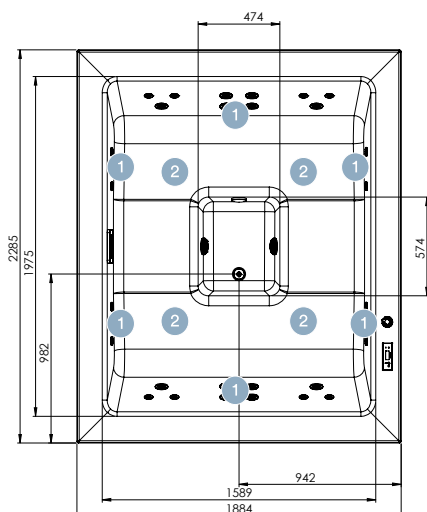

- 1 Whirlpool
- 2 Airpool

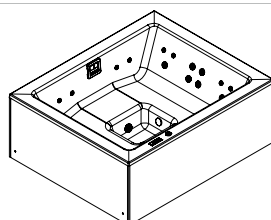

MASSAGGI /
Massages / Massages /
Masajes / Massagen

- Respiro profondo**
- Onda Suprema**

- 2 **Solo Plus / Plus only / Version Plus**
uniquement / Solo Plus / Nur Plus

Per le misure esterne considerare una tolleranza di ± 5 mm
For the external dimensions, allow a tolerance of ± 5 mm
Pour les dimensions extérieures, prévoir une tolérance de ± 5 mm
Para las medidas exteriores, considerar una tolerancia de ± 5 mm
Für die Außenmaße ist eine Toleranz von ± 5 mm zu berücksichtigen

Miris Pool

DESIGN // ALBATROS R&D



200 x 150 - h 67 cm

480 lt | max

128 kg

x2 | n° max

Finiture / Finishes / Finitions / Acabados / Oberflächen

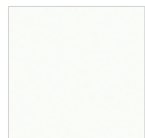

Molded White

Pannelli Panels / Panneaux / Paneles / Panele B-PLUS



Elegant Tea For Two (TT)



Tortona Natural (TN)



Graphite (GP)



Kashmir (KS)

DOTAZIONI / FEATURES / ÉQUIPEMENTS / EQUIPAMIENTO / AUSSTATTUNG **STANDARD** **PLUS**

Whirlpool Jets	16	16
Airpool Jets	-	16
Bocchette / Nozzles / Buses / Boquillas / Düsen	FilJets	FilJets
Disinfezione con Sistema UV / UV Disinfection System / Système de désinfection UV / Sistema de desinfección UV / UV-Desinfektionssystem	-	✓
Cromoterapia / Chromotherapy / Chromothérapie / Cromoterapia / Farbtherapie	-	✓
Riscaldatore 3Kw / 3kW Heater / Chauffage 3kW / Calentador de 3kW / 3kW-Heizung	✓	✓
Pompe / Pumps / Pompes / Bombas / Pumpen	1	2
Carico-scarico semi-automatico / Semi-automatic filling and draining system / Système de remplissage et vidage / Sistema de llenado y vaciado semiautomático / Halbautomatisches Befüll- und Entleerungssystem	✓	✓
Filtro a cartuccia / Cartridge Filter / Filtre à cartouche / Filtro de cartucho / Kartuschenfilter	✓	✓
Skimmer a parete / Wall-mounted skimmer / Skimmer mural / Skimmer de pared / Wandskimmer	✓	✓
Touch Display	✓	✓

GREEN PLUS



Molded White

Greytek

MIRIS POOL STANDARD

04MI20STBN 8.800

MIRIS POOL PLUS

04MI20PLBN 10.700

Copertura termica Thermal Cover / Couverture thermique / Cubierta térmica / Thermoabdeckung

04MICT00 1.500

GLAMOUR SPA

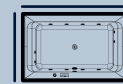

Miris

Pannelli / Panels / Panneaux / Paneles / Paneele + 0 cm

Elegant Tea For Two (TT)

40EMPRTT 2.500

Tortona Natural (TN)

40EMPRTN 2.500

Graphite (GP)

40EMPRGP 2.500

Kashmir (KS)

40EMPRKS 2.500

Optional

Codice

Poggiatesta / Headrest / Appuie-tête / Reposacabezas / Kopfstütze

40MICS00 250

Command Spa

40CMS00 600

Filtro a sabbia esterno / External sand filter / Filtre à sable externe / Filtro de arena externo / Externer Sandfilter

40FILS01 1.700

Kit Mantenimento Spa / Spa Maintenance Kit / Kit d'entretien Spa / Kit de mantenimiento Spa / Spa-Pflegekit

40KITMAN 320

Kit Pulizia Spa / Spa Cleaning Kit / Kit de nettoyage Spa / Kit de limpieza Spa / Spa-Reinigungsset

40KITPUL 120



Scopri i nostri sistemi di idromassaggio
 / Discover our hydromassage systems
 / Découvrez nos systèmes de hydromassage
 / Descubre nuestros sistemas de hidromasaje
 / Entdecken Sie unsere Hydromassage-Systeme

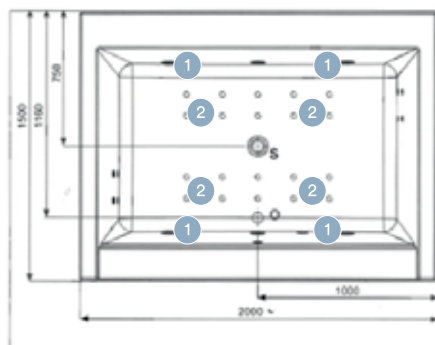

1 Whirlpool

2 Airpool

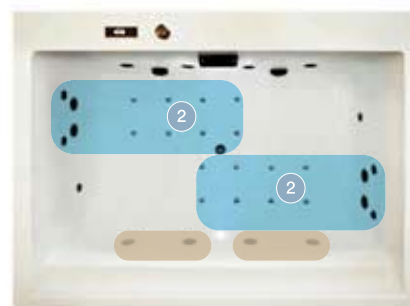

MASSAGGI /
 Massages / Massages /
 Masajes / Massagen

Ali di Energia

Armonia Totale

2 Solo Plus / Plus only / Version Plus
 uniquement / Solo Plus / Nur Plus

Per le misure esterne considerare una tolleranza di ± 5 mm
 For the external dimensions, allow a tolerance of ± 5 mm
 Pour les dimensions extérieures, prévoir une tolérance de ± 5 mm
 Para las medidas exteriores, considerar una tolerancia de ± 5 mm
 Für die Außenmaße ist eine Toleranz von ± 5 mm zu berücksichtigen

Elite Pool

DESIGN // CLAUDIO PAPA



188 x 188 - h 94 cm

700 lt | max

280 kg

x1
 x3
n° max

Finiture / Finishes / Finitions / Acabados / Oberflächen

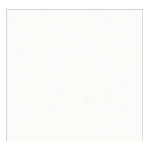

Molded White

Pannelli Panels / Panneaux / Paneles / Panele B-PLUS



Elegant Tea For Two (TT)



Tortona Natural (TN)



Graphite (GP)



Kashmir (KS)

DOTAZIONI / FEATURES / ÉQUIPEMENTS / EQUIPAMIENTO / AUSSTATTUNG **STANDARD** **PLUS**

Whirlpool Jets	24	24
Airpool Jets	-	8
Bocchette / Nozzles / Buses / Boquillas / Düsen	FilJet	FilJet
Disinfezione con Sistema UV / UV Disinfection System / Système de désinfection UV / Sistema de desinfección UV / UV-Desinfektionssystem	-	✓
Cromoterapia / Chromotherapy / Chromothérapie / Cromoterapia / Farbtherapie	-	✓
Riscaldatore 3Kw / 3kW Heater / Chauffage 3kW / Calentador de 3kW / 3kW-Heizung	✓	✓
Pompe / Pumps / Pompes / Bombas / Pumpen	1 2speed	1
Pompa Silence Spa / Silence Spa pump / Pompe Silence Spa / Bomba Silence Spa / Silence Spa Pumpe	-	1
Carico-scarico semi-automatico / Semi-automatic filling and draining system / Système de remplissage et vidage / Sistema de llenado y vaciado semiautomático / Halbautomatisches Befüll-und Entleerungssystem	✓	✓
Filtro a cartuccia / Cartridge Filter / Filtre à cartouche / Filtro de cartucho / Kartuschenfilter	✓	✓
Skimmer a parete / Wall-mounted skimmer / Skimmer mural / Skimmer de pared / Wandskimmer	✓	✓
Display Touch	✓	✓

GREEN PLUS



ENERGY SAVING



MICROBAN



SILENCE SPA



COMMAND SPA

	Molded White	Greytek
ELITE POOL STANDARD	04EP18STBN	14.800
ELITE POOL PLUS	04EP18PLBN	16.800
Copertura termica <i>Thermal Cover / Couverture thermique / Cubierta térmica / Thermoabdeckung</i>		40EPC00 1.900



Pannelli / Panels / Panneaux /
Paneles / Panele + 0 cm

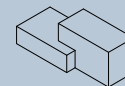

Scaletta / Access Ladder /
Échelle d'accès / Escalera de
acceso / Einstiegsleiter

Elegant Tea For Two (TT)	40EPPRTT	4.000	40XXSCTT	2.000
Tortona Natural (TN)	40EPPRTN	4.000	40XXSCTN	2.000
Graphite (GP)	40EPPRGP	4.000	40XXSCGP	2.000
Kashmir (KS)	40EPPRKS	4.000	40XXSCKS	2.000

Optional	Codice	
Micro Silk	40MCSK00	2.850
Scambiatore di Calore / Heat exchanger / Échangeur de chaleur / Intercambiador de calor / Wärmetauscher	40SDC00	Su richiesta / On request / Sur demande / Bajo solicitud / Auf Anfrage
Command Spa	40CMS00	600
Filtro a sabbia esterno / External sand filter / Filtre à sable externe / Filtro de arena externo / Externer Sandfilter	40FILS01	1.700
Kit Mantenimento Spa / Spa Maintenance Kit / Kit d'entretien Spa / Kit de mantenimiento Spa / Spa-Pflegekit	40KITMAN	320
Kit Pulizia Spa / Spa Cleaning Kit / Kit de nettoyage Spa / Kit de limpieza Spa / Spa-Reinigungsset	40KITPUL	120



Scopri i nostri sistemi di idromassaggio
/ Discover our hydromassage systems
/ Découvrez nos systèmes de hydromassage
/ Descubre nuestros sistemas de hidromasaje
/ Entdecken Sie unsere Hydromassage-Systeme

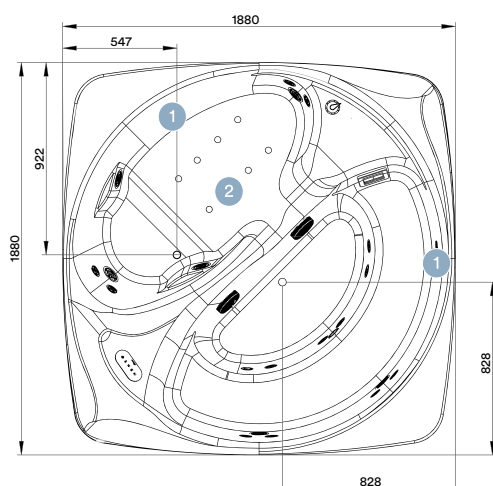

1 Whirlpool

2 Airpool

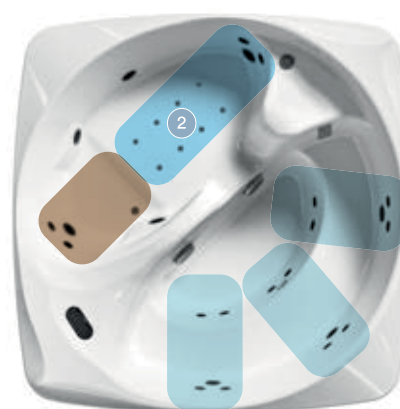
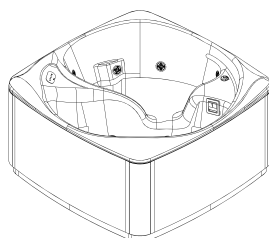

MASSAGGI /
Massages / Massages /
Masajes / Massagen

-  **Leggerezza**
-  **Armonia Totale**
-  **Radici Forti**

2 **Solo Plus / Plus only / Version Plus**
uniquement / Solo Plus / Nur Plus

Per le misure esterne considerare una tolleranza di ± 5 mm
For the external dimensions, allow a tolerance of ± 5 mm
Pour les dimensions extérieures, prévoir une tolérance de ± 5 mm
Para las medidas exteriores, considerar una tolerancia de ± 5 mm
Für die Außenmaße ist eine Toleranz von ± 5 mm zu berücksichtigen

Marvelia Pool

DESIGN // ALBATROS R&D



 190 x 120 - h 61 cm

 340 lt | max

 120 kg

 x2 | n° max

Finiture / Finishes / Finitions / Acabados / Oberflächen

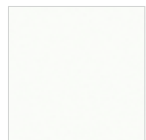

Molded White

Pannelli Panels / Panneaux / Paneles / Panele B-PLUS



Elegant Tea For Two (TT)













Tortona Natural (TN)



Graphite (GP)



Kashmere (KS)

DOTAZIONI / FEATURES / ÉQUIPEMENTS / EQUIPAMIENTO / AUSSTATTUNG	STANDARD	PLUS
 Whirlpool Jets	12	12
 Airpool Jets	-	12
 Bocchette / Nozzles / Buses / Boquillas / Düsen	FillJets	FillJets
 Disinfezione con Sistema UV / UV Disinfection System / Système de désinfection UV / Sistema de desinfección UV / UV-Desinfektionssystem	-	✓
 Cromoterapia / Chromotherapy / Chromothérapie / Cromoterapia / Farbtherapie	-	✓
 Riscaldatore 3Kw / 3kW Heater / Chauffage 3kW / Calentador de 3kW / 3kW-Heizung	✓	✓
 Pompe / Pumps / Pompes / Bombas / Pumpen	1	2
 Carico-scarico semi-automatico / Semi-automatic filling and draining system / Système de remplissage et vidage / Sistema de llenado y vaciado semiautomático / Halbautomatisches Befüll- und Entleerungssystem	✓	✓
 Filtro a cotone / Cotton Filter / Filtre en coton / Filtro de algodón / Baumwollfilter	✓	✓
 Touch Display	✓	✓

GREEN PLUS



ENERGY SAVING



MICROBAN

Molded White

Greytek

MARVELIA POOL STANDARD

04MA19STBN 8.500

MARVELIA POOL PLUS

04MA19PLBN 10.400

Copertura termica Thermal Cover / Couverture thermique / Cubierta térmica / Thermoabdeckung

04MACT00 1.400

GLAMOUR SPA



Marvelia

Pannelli / Panels / Panneaux / Paneles / Paneele + 0 cm

Elegant Tea For Two (TT)

40EMPRTT 2.200

Tortona Natural (TN)

40EMPRTN 2.200

Graphite (GP)

40EMPRGP 2.200

Kashmir (KS)

40EMPRKS 2.200

Optional

Codice

Poggiatesta / Headrest / Appuie-tête / Reposacabezas / Kopfstütze

40MACS00 250

Command Spa

40CMS00 600

Filtro a sabbia esterno / External sand filter / Filtre à sable externe / Filtro de arena externo / Externer Sandfilter

40FILS01 1.700

Kit Hot & Ice

40HICE0 3.900

Kit Mantenimento Spa / Spa Maintenance Kit / Kit d'entretien Spa / Kit de mantenimiento Spa / Spa-Pflegekit

40KITMAN 320

Kit Pulizia Spa / Spa Cleaning Kit / Kit de nettoyage Spa / Kit de limpieza Spa / Spa-Reinigungsset

40KITPUL 120



Scopri i nostri sistemi di idromassaggio
 / Discover our hydromassage systems
 / Découvrez nos systèmes de hydromassage
 / Descubre nuestros sistemas de hidromasaje
 / Entdecken Sie unsere Hydromassage-Systeme

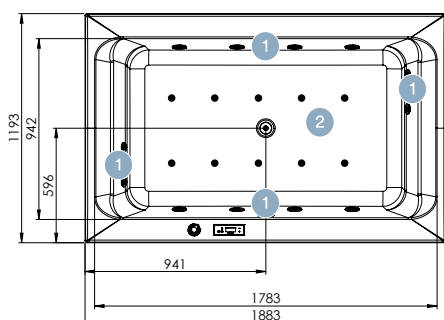

1 Whirlpool

2 Airpool

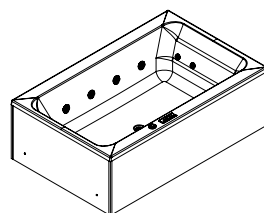

MASSAGGI /
 Massages / Massages /
 Masajes / Massagen

Ali di Energia

Armonia Totale

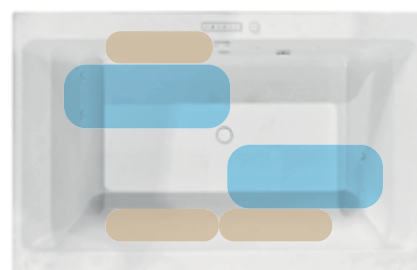

2 Solo Plus / Plus only / Version Plus
 uniquement / Solo Plus / Nur Plus

Per le misure esterne considerare una tolleranza di ± 5 mm
 For the external dimensions, allow a tolerance of ± 5 mm
 Pour les dimensions extérieures, prévoir une tolérance de ± 5 mm
 Para las medidas exteriores, considerar una tolerancia de ± 5 mm
 Für die Außenmaße ist eine Toleranz von ± 5 mm zu berücksichtigen

Soreha Mini Pool

DESIGN // ALBATROS R&D



 180 x 180 - h 57 cm

 480 lt | max

 128 kg

 x2 | n° max

**Finiture / Finishes /
Finitions / Acabados /
Oberflächen**

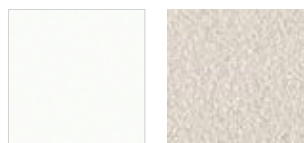

Molded White **Molded Madreperla**

**Pannelli Panels /
Panneaux / Paneles /
Panele B-PLUS**



**Elegant Tea For
Two (TT)**



**Tortona
Natural (TN)**















Graphite (GP)



Kashmir (KS)

DOTAZIONI / FEATURES / ÉQUIPEMENTS / EQUIPAMIENTO / AUSSTATTUNG **STANDARD** **PLUS**

 Whirlpool Jets	28	28
 Airpool Jets	-	12
 Bocchette / Nozzles / Buses / Boquillas / Düsen	FilJet	FilJet
 Disinfezione con Sistema UV / UV Disinfection System / Système de désinfection UV / Sistema de desinfección UV / UV-Desinfektionssystem	-	✓
 Cromoterapia / Chromotherapy / Chromothérapie / Cromoterapia / Farbtherapie	-	✓
 Riscaldatore 3Kw / 3kW Heater / Chauffage 3kW / Calentador de 3kW / 3kW-Heizung	✓	✓
 Pompe / Pumps / Pompes / Bombas / Pumpen	2	1
 Pompa Silence Spa / Silence Spa pump / Pompe Silence Spa / Bomba Silence Spa / Silence Spa Pumpe	-	1
 Carico-scarico semi-automatico / Semi-automatic filling and draining system / Système de remplissage et vidage / Sistema de llenado y vaciado semiautomático / Halbautomatisches Befüll- und Entleerungssystem	✓	✓
 Filtro a cartuccia / Cartridge Filter / Filtre à cartouche / Filtro de cartucho / Kartuschenfilter	✓	✓
 Skimmer a parete / Wall-mounted skimmer / Skimmer mural / Skimmer de pared / Wandskimmer	✓	✓
 Materassino / Mat / Matelas / Colchoneta / Matte	✓	✓
 Touch Display	✓	✓

GREEN PLUS



ENERGY SAVING



MICROBAN



SILENCE SPA



COMMAND SPA

	Molded White		Molded Madreperla		Greytek
SOREHA MINI POOL STANDARD	04SO18STBN	8.600	04SO18STPN	8.900	
SOREHA MINI POOL PLUS	04SO18PLBN	11.000	04SO18PLPN	11.300	

Copertura termica Thermal Cover / Couverture thermique / Cubierta térmica / Thermoabdeckung

40THCT00 1.500

Pannelli / Panels / Panneaux / Paneles / Paneele + 3 cm

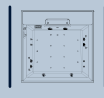
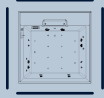

Elegant Tea For Two (TT)	40SO4FTT	2.700	40SO3FTT	2.400	40SO2FTT	1.800	40SO1FTT	1.000
Tortona Natural (TN)	40SO4FTN	2.700	40SO3FTN	2.400	40SO2FTN	1.800	40SO1FTN	1.000
Graphite (GP)	40SO4FGP	2.700	40SO3FGP	2.400	40SO2FGP	1.800	40SO1FGP	1.000
Kashmir (KS)	40SO4FKS	2.700	40SO3FKS	2.400	40SO2FKS	1.800	40SO1FKS	1.000

Optional	Codice	
Scambiatore di Calore / Heat exchanger / Échangeur de chaleur / Intercambiador de calor / Wärmetauscher	40SDC00	Su richiesta / On request / Sur demande / Bajo solicitud / Auf Anfrage
Command Spa	40CMS00	600
Filtro a sabbia esterno / External sand filter / Filtre à sable externe / Filtro de arena externo / Externer Sandfilter	40FILS01	1.700
Kit Mantenimento Spa / Spa Maintenance Kit / Kit d'entretien Spa / Kit de mantenimiento Spa / Spa-Pflegekit	40KITMAN	320
Kit Pulizia Spa / Spa Cleaning Kit / Kit de nettoyage Spa / Kit de limpeza Spa / Spa-Reinigungsset	40KITPUL	120



Scopri i nostri sistemi di idromassaggio
 / Discover our hydromassage systems
 / Découvrez nos systèmes de hydromassage
 / Descubre nuestros sistemas de hidromasaje
 / Entdecken Sie unsere Hydromassage-Systeme

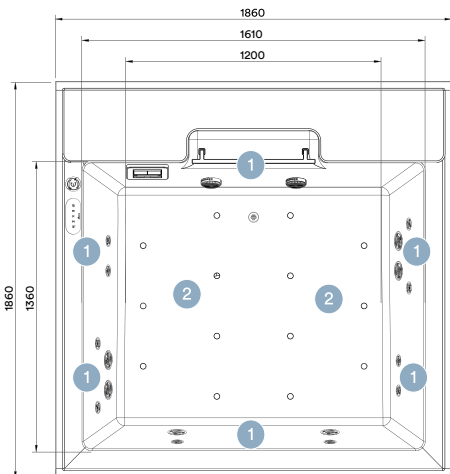

- 1 Whirlpool
- 2 Airpool

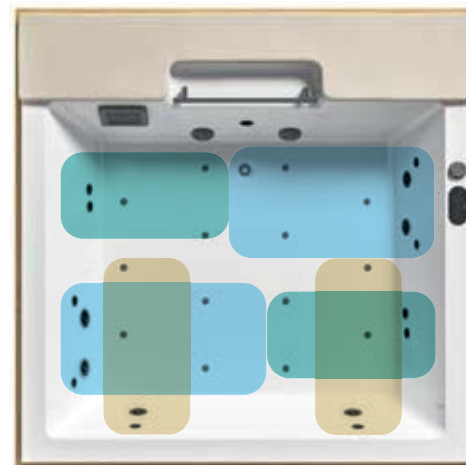
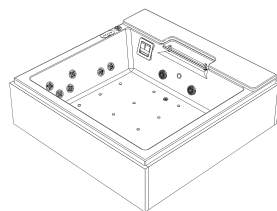

MASSAGGI / Massages / Massages / Masajes / Massagen

- Equilibrio
- Armonia Totale
- Abbraccio d'acqua

2 **Solo Plus / Plus only / Version Plus uniquement / Solo Plus / Nur Plus**

Per le misure esterne considerare una tolleranza di ± 5mm
 For the external dimensions, allow a tolerance of ± 5 mm
 Pour les dimensions extérieures, prévoir une tolérance de ± 5 mm
 Para las medidas exteriores, considerar una tolerancia de ± 5 mm
 Für die Außenmaße ist eine Toleranz von ± 5 mm zu berücksichtigen

Aster Pool

DESIGN // ALBATROS R&D



 140 x 140 - h 60 cm

 340 lt | max

 110 kg

 x2 | n° max

Finiture / Finishes / Finitions / Acabados / Oberflächen

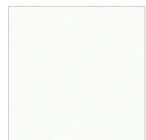

Sprayed White

Pannelli Panels / Panneaux / Paneles / Panele B-PLUS



Elegant Tea For Two (TT)











Tortona Natural (TN)



Graphite (GP)



Kashmir (KS)

DOTAZIONI / FEATURES / ÉQUIPEMENTS / EQUIPAMIENTO / AUSSTATTUNG	STANDARD	PLUS
 Whirlpool Jets	12	12
 Airpool Jets	-	12
 Bocchette / Nozzles / Buses / Boquillas / Düsen	FillJets	FillJets
 Cromoterapia / Chromotherapy / Chromothérapie / Cromoterapia / Farbtherapie	-	✓
 Riscaldatore 3Kw / 3kW Heater / Chauffage 3kW / Calentador de 3kW / 3kW-Heizung	✓	✓
 Pompe / Pumps / Pompes / Bombas / Pumpen	1	2
 Carico-scarico semi-automatico / Semi-automatic filling and draining system / Système de remplissage et vidage / Sistema de llenado y vaciado semiautomático / Halbautomatisches Befüll- und Entleerungssystem	✓	✓
 Filtro a cotone / Cotton Filter / Filtre en coton / Filtro de algodón / Baumwollfilter	✓	✓
 Touch Display	✓	✓

GREEN PLUS



ENERGY SAVING



MICROBAN

	Sprayed White	Greytek
ASTER POOL STANDARD	04AS18STBN	8.900
ASTER POOL PLUS	04AS18PLBN	10.500
Copertura termica <i>Thermal Cover / Couverture thermique / Cubierta térmica / Thermoabdeckung</i>		40ASCT00 1.300

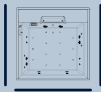
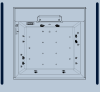
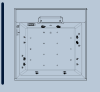
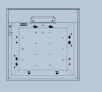
Pannelli / Panels / Panneaux / Paneles / Pannele + 0 cm								
Elegant Tea For Two (TT)	40AS4FTT	1.900	40AS3FTT	1.700	40AS2FTT	1.200	40AS1FTT	800
Tortona Natural (TN)	40AS4FTN	1.900	40AS3FTN	1.700	40AS2FTN	1.200	40AS1FTN	800
Graphite (GP)	40AS4FGP	1.900	40AS3FGP	1.700	40AS2FGP	1.200	40AS1FGP	800
Kashmir (KS)	40AS4FKS	1.900	40AS3FKS	1.700	40AS2FKS	1.200	40AS1FKS	800

Optional	Codice	
Poggiatesta / Headrest / Appuie-tête / Reposacabezas / Kopfstütze	40SOCS00	250
Scambiatore di Calore / Heat exchanger / Échangeur de chaleur / Intercambiador de calor / Wärmetauscher	40SDC00	Su richiesta / On request / Sur demande / Bajo solicitud / Auf Anfrage
Command Spa	40CMS00	600
Filtro a sabbia esterno / External sand filter / Filtre à sable externe / Filtro de arena externo / Externer Sandfilter	40FILS01	1.700
Kit Mantenimento Spa / Spa Maintenance Kit / Kit d'entretien Spa / Kit de mantenimiento Spa / Spa-Pflegekit	40KITMAN	320
Kit Pulizia Spa / Spa Cleaning Kit / Kit de nettoyage Spa / Kit de limpieza Spa / Spa-Reinigungsset	40KITPUL	120



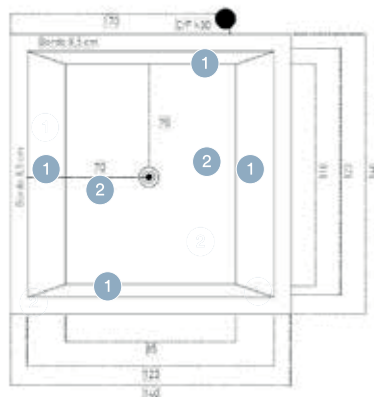

Scopri i nostri sistemi di idromassaggio
 / Discover our hydromassage systems
 / Découvrez nos systèmes de hydromassage
 / Descubre nuestros sistemas de hidromasaje
 / Entdecken Sie unsere Hydromassage-Systeme



- 1 Whirlpool**
- 2 Airpool**



**MASSAGGI /
 Massages / Massages /
 Masajes / Massagen**

-  **Ali di Energia**
-  **Armonia Totale**
-  **Sostegno Avvolgente**

**2 Solo Plus / Plus only / Version Plus
 uniquement / Solo Plus / Nur Plus**

Per le misure esterne considerare una tolleranza di ± 5mm
 For the external dimensions, allow a tolerance of ± 5 mm
 Pour les dimensions extérieures, prévoir une tolérance de ± 5 mm
 Para las medidas exteriores, considerar una tolerancia de ± 5 mm
 Für die Außenmaße ist eine Toleranz von ± 5 mm zu berücksichtigen

Privè R07 Ø 231 h 94

Privè 405 230x230 h 94

Privè 306 221x221 h 94

Privè 206 222x191 h 94

Privè 103 221,5x179,5 h 94

Albatros

04

Minipiscine Privè

PRIVÈ SPA

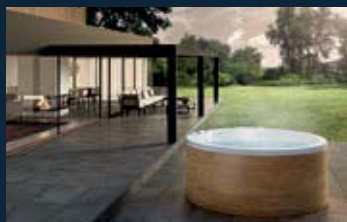

Privè R07
pag. 54



Privè 405
pag. 56



Privè 306
pag. 58



Privè 206
pag. 60



Privè 103
pag. 62

Privè R07

DESIGN // ALBATROS R&D



 Ø 231 - h 94 cm

 1200 lt | m³ max

 **290 kg**

 x7 | n° max

Finiture / Finishes / Finitions / Acabados / Oberflächen

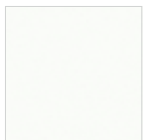

Molded White

Pannelli Panels / Panneaux / Paneles / Panele B-PLUS



Elegant Tea For Two (TT)

DOTAZIONI / FEATURES / ÉQUIPEMENTS / EQUIPAMIENTO / AUSSTATTUNG

PLUS

	Whirlpool Jets	28
	Airpool Jets	15
	Bocchette / Nozzles / Buses / Boquillas / Düsen	JetPool
	Disinfezione con Sistema UV / UV Disinfection System / Système de désinfection UV / Sistema de desinfección UV / UV-Desinfektionssystem	✓
	Cromoterapia / Chromotherapy / Chromothérapie / Cromoterapia / Farbtherapie	✓
	Riscaldatore 3Kw / 3kW Heater / Chauffage 3kW / Calentador de 3kW / 3kW-Heizung	✓
	Pompe / Pumps / Pompes / Bombas / Pumpen	2
	Scarico semi-automatico / Semi-automatic Drain / Vidange semi-automatique / Drenaje semiautomático / Halbautomatischer Ablauf	✓
	Filtro a cartuccia / Cartridge Filter / Filtre à cartouche / Filtro de cartucho / Kartuschenfilter	✓
	Skimmer flottante / Floating skimmer / Skimmer flottant / Skimmer flotante / Schwimmender Skimmer	✓
	Touch Display	✓

GREEN PLUS



ENERGY SAVING



MICROBAN

Molded White

Greytek

PRIVÈ R07

04PAB231 14.400

Copertura termica *Thermal Cover / Couverture thermique / Cubierta térmica / Thermoabdeckung*

40PACT00 2.300

Optional



**Pannelli / Panels / Panneaux /
Paneles / Paneele + 0 cm**



**Scaletta / Access Ladder /
Échelle d'accès / Escalera de
acceso / Einstiegsleiter**

Elegant Tea For Two (TT)

40PA4FTT

4.200

40PASCTT

1.200

Optional

Codice

Micro Silk

40MCSK00

2.850

Scambiatore di Calore / Heat exchanger / Échangeur de chaleur / Intercambiador de calor / Wärmetauscher

40SDC00

**Su richiesta / On request / Sur demande
/ Bajo solicitud / Auf Anfrage**

Command Spa

40CMS00

600

Filtro a sabbia esterno / External sand filter / Filtre à sable externe / Filtro de arena externo / Externer Sandfilter

40FILS01

1.700

Kit Mantenimento Spa / Spa Maintenance Kit / Kit d'entretien Spa / Kit de mantenimiento Spa / Spa-Pflegekit

40KITMAN

320

Kit Pulizia Spa / Spa Cleaning Kit / Kit de nettoyage Spa / Kit de limpieza Spa / Spa-Reinigungsset

40KITPUL

120



Scopri i nostri sistemi di idromassaggio
/ Discover our hydromassage systems
/ Découvrez nos systèmes de hydromassage
/ Descubre nuestros sistemas de hidromasaje
/ Entdecken Sie unsere Hydromassage-Systeme



Scopri il funzionamento Microsilik®
/ Discover how Microsilik® works
/ Découvrez le fonctionnement de Microsilik®
/ Descubra el funcionamiento de Microsilik®
/ Entdecken Sie die Funktionsweise von Microsilik®

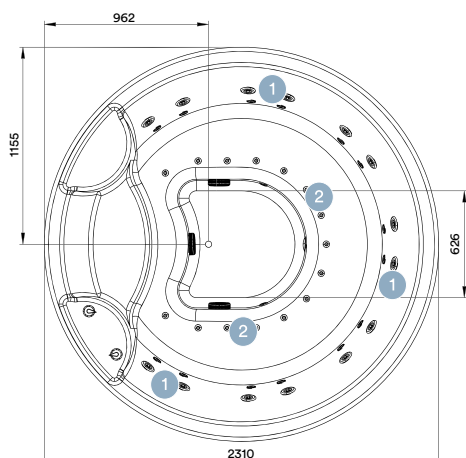

1 Whirlpool

2 Airpool

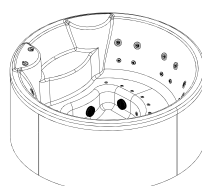

**MASSAGGI /
Massages / Massages /
Masajes / Massagen**

Benessere Profondo

Per le misure esterne considerare una tolleranza di ± 5mm
For the external dimensions, allow a tolerance of ± 5 mm
Pour les dimensions extérieures, prévoir une tolérance de ± 5 mm
Para las medidas exteriores, considerar una tolerancia de ± 5 mm
Für die Außenmaße ist eine Toleranz von ± 5 mm zu berücksichtigen

Privè 405

DESIGN // ALBATROS R&D



230 x 230 - h 94 cm

1300 lt | max

330 kg

x2
 x3
n° max

Finiture / Finishes / Finitions / Acabados / Oberflächen

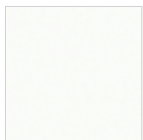

Molded White

Pannelli Panels / Panneaux / Paneles / Panele B-PLUS



Elegant Tea For Two (TT)

DOTAZIONI / FEATURES / ÉQUIPEMENTS / EQUIPAMIENTO / AUSSTATTUNG

PLUS

	Whirlpool Jets	47
	Airpool Jets	10
	Bocchette / Nozzles / Buses / Boquillas / Düsen	JetPool
	Disinfezione con Sistema UV / UV Disinfection System / Système de désinfection UV / Sistema de desinfección UV / UV-Desinfektionssystem	✓
	Cromoterapia / Chromotherapy / Chromothérapie / Cromoterapia / Farbtherapie	✓
	Riscaldatore 3Kw / 3kW Heater / Chauffage 3kW / Calentador de 3kW / 3kW-Heizung	✓
	Pompe / Pumps / Pompes / Bombas / Pumpen	2
	Scarico semi-automatico / Semi-automatic Drain / Vidange semi-automatique / Drenaje semiautomático / Halbautomatischer Ablauf	✓
	Filtro a cartuccia / Cartridge Filter / Filtre à cartouche / Filtro de cartucho / Kartuschenfilter	✓
	Skimmer Flottante / Floating skimmer / Skimmer flottant / Skimmer flotante / Schwimmender Skimmer	✓
	Touch Display	✓

GREEN PLUS



ENERGY SAVING



MICROBAN

Molded White

Greytek

PRIVÈ 405

04OAB221 15.800

Copertura termica Thermal Cover / Couverture thermique / Cubierta térmica / Thermoabdeckung

40OACT00 1.900

Optional



Pannelli / Panels / Panneaux /
Paneles / Paneele + 0 cm



Scaletta / Access Ladder /
Échelle d'accès / Escalera de
acceso / Einstiegsleiter

Elegant Tea For Two (TT)

40OA4FTT

3.400

40PRSC TT

900

PRIVÈ
SPA

Optional

Codice

Micro Silk

40MCSK00

2.850

Scambiatore di Calore / Heat exchanger / Échangeur de chaleur / Intercambiador de calor / Wärmetauscher

40SDC00

Su richiesta / On request / Sur demande
/ Bajo solicitud / Auf Anfrage

Command Spa

40CMS00

600

Filtro a sabbia esterno / External sand filter / Filtre à sable externe / Filtro de arena externo / Externer Sandfilter

40FILS01

1.700

Kit Mantenimento Spa / Spa Maintenance Kit / Kit d'entretien Spa / Kit de mantenimiento Spa / Spa-Pflegekit

40KITMAN

320

Kit Pulizia Spa / Spa Cleaning Kit / Kit de nettoyage Spa / Kit de limpieza Spa / Spa-Reinigungsset

40KITPUL

120



Scopri i nostri sistemi di idromassaggio
/ Discover our hydromassage systems
/ Découvrez nos systèmes de hydromassage
/ Descubre nuestros sistemas de hidromasaje
/ Entdecken Sie unsere Hydromassage-Systeme



Scopri il funzionamento Microsilik®
/ Discover how Microsilik® works
/ Découvrez le fonctionnement de Microsilik®
/ Descubra el funcionamiento de Microsilik®
/ Entdecken Sie die Funktionsweise von Microsilik®

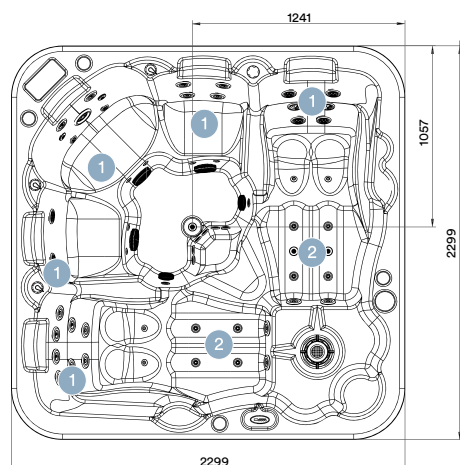

- 1 Whirlpool
- 2 Airpool

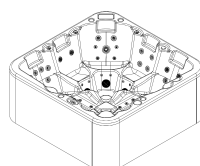

MASSAGGI /
Massages / Massages /
Masajes / Massagen

- Energia Totale
- Risveglio Dolce
- Sollievo
- Distensione
- Comfort

Per le misure esterne considerare una tolleranza di ± 5 mm
For the external dimensions, allow a tolerance of ± 5 mm
Pour les dimensions extérieures, prévoir une tolérance de ± 5 mm
Para las medidas exteriores, considerar una tolerancia de ± 5 mm
Für die Außenmaße ist eine Toleranz von ± 5 mm zu berücksichtigen

Privè 306

DESIGN // ALBATROS R&D



 221 x 221 - h 94 cm

 1400 lt | max

 330 kg

 x1
 x5
n° max

Finiture / Finishes / Finitions / Acabados / Oberflächen

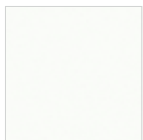

Molded White

Pannelli Panels / Panneaux / Paneles / Panele



Elegant Tea For Two (TT)

DOTAZIONI / FEATURES / ÉQUIPEMENTS / EQUIPAMIENTO / AUSSTATTUNG

PLUS

	Whirlpool Jets	41
	Airpool Jets	10
	Bocchette / Nozzles / Buses / Boquillas / Düsen	JetPool
	Disinfezione con Sistema UV / UV Disinfection System / Système de désinfection UV / Sistema de desinfección UV / UV-Desinfektionssystem	✓
	Cromoterapia / Chromotherapy / Chromothérapie / Cromoterapia / Farbtherapie	✓
	Riscaldatore 3Kw / 3kW Heater / Chauffage 3kW / Calentador de 3kW / 3kW-Heizung	✓
	Pompe / Pumps / Pompes / Bombas / Pumpen	2
	Scarico semi-automatico / Semi-automatic Drain / Vidange semi-automatique / Drenaje semiautomático / Halbautomatischer Ablauf	✓
	Filtro a cartuccia / Cartridge Filter / Filtre à cartouche / Filtro de cartucho / Kartuschenfilter	✓
	Skimmer Flottante / Floating skimmer / Skimmer flottant / Skimmer flotante / Schwimmender Skimmer	✓
	Touch Display	✓

GREEN PLUS



ENERGY SAVING



MICROBAN

Molded White

Greytek

PRIVÈ 306

04GRB21 15.600

Copertura termica Thermal Cover / Couverture thermique / Cubierta térmica / Thermoabdeckung

40GRCT00 1.800

Optional



Pannelli / Panels / Panneaux / Paneles / Paneele + 0 cm



Scaletta / Access Ladder / Échelle d'accès / Escalera de acceso / Einstiegsleiter

Elegant Tea For Two (TT)

40GR4FTT

3.300

40PRSC TT

900

PRIVÈ SPA

Optional

Codice

Micro Silk

40MCSK00

2.850

Scambiatore di Calore / Heat exchanger / Échangeur de chaleur / Intercambiador de calor / Wärmetauscher

40SDC00

Su richiesta / On request / Sur demande / Bajo solicitud / Auf Anfrage

Command Spa

40CMS00

600

Filtro a sabbia esterno / External sand filter / Filtre à sable externe / Filtro de arena externo / Externer Sandfilter

40FILS01

1.700

Kit Mantenimento Spa / Spa Maintenance Kit / Kit d'entretien Spa / Kit de mantenimiento Spa / Spa-Pflegekit

40KITMAN

320

Kit Pulizia Spa / Spa Cleaning Kit / Kit de nettoyage Spa / Kit de limpieza Spa / Spa-Reinigungsset

40KITPUL

120



Scopri i nostri sistemi di idromassaggio / Discover our hydromassage systems / Découvrez nos systèmes de hydromassage / Descubre nuestros sistemas de hidromasaje / Entdecken Sie unsere Hydromassage-Systeme



Scopri il funzionamento Microsilik® / Discover how Microsilik® works / Découvrez le fonctionnement de Microsilik® / Descubra el funcionamiento de Microsilik® / Entdecken Sie die Funktionsweise von Microsilik®

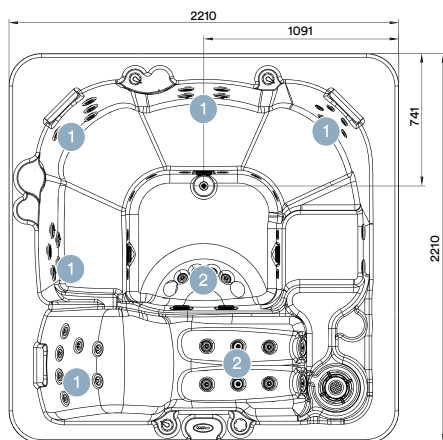

1 Whirlpool

2 Airpool

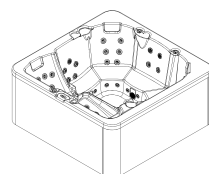

MASSAGGI /
Massages / Massages /
Masajes / Massagen

- Energia Totale**
- Vitalità**
- Movimento**
- Distensione**
- Comfort**
- Flusso Vitale**

Per le misure esterne considerare una tolleranza di ± 5 mm
For the external dimensions, allow a tolerance of ± 5 mm
Pour les dimensions extérieures, prévoir une tolérance de ± 5 mm
Para las medidas exteriores, considerar una tolerancia de ± 5 mm
Für die Außenmaße ist eine Toleranz von ± 5 mm zu berücksichtigen

Privè 206

DESIGN // ALBATROS R&D



 222 x 191 - h 94 cm

 1200 lt | max

 320 kg

 x6 | n° max

Finiture / Finishes / Finitions / Acabados / Oberflächen

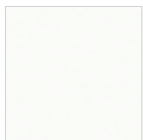

Molded White

Pannelli Panels / Panneaux / Paneles / Panele B-PLUS



Elegant Tea For Two (TT)

DOTAZIONI / FEATURES / ÉQUIPEMENTS / EQUIPAMIENTO / AUSSTATTUNG

PLUS

	Whirlpool Jets	36
	Airpool Jets	10
	Bocchette / Nozzles / Buses / Boquillas / Düsen	JetPool
	Disinfezione con Sistema UV / UV Disinfection System / Système de désinfection UV / Sistema de desinfección UV / UV-Desinfektionssystem	✓
	Cromoterapia / Chromotherapy / Chromothérapie / Cromoterapia / Farbtherapie	✓
	Riscaldatore 3Kw / 3kW Heater / Chauffage 3kW / Calentador de 3kW / 3kW-Heizung	✓
	Pompe / Pumps / Pompes / Bombas / Pumpen	2
	Scarico semi-automatico / Semi-automatic Drain / Vidange semi-automatique / Drenaje semiautomático / Halbautomatischer Ablauf	✓
	Filtro a cartuccia / Cartridge Filter / Filtre à cartouche / Filtro de cartucho / Kartuschenfilter	✓
	Skimmer Flottante / Floating skimmer / Skimmer flottant / Skimmer flotante / Schwimmender Skimmer	✓
	Touch Display	✓

GREEN PLUS



ENERGY SAVING



MICROBAN

Molded White

Greytek

PRIVÈ 206

04CSB222 14.900

Copertura termica Thermal Cover / Couverture thermique / Cubierta térmica / Thermoabdeckung

40CSCT00 1.700

Optional



Pannelli / Panels / Panneaux / Paneles / Paneele + 0 cm



Scaletta / Access Ladder / Échelle d'accès / Escalera de acceso / Einstiegsleiter

Elegant Tea For Two (TT)

40CS4FTT

3.100

40PRSC TT

900

Optional

Codice

Micro Silk	40MCSK00	2.850
Scambiatore di Calore / Heat exchanger / Échangeur de chaleur / Intercambiador de calor / Wärmetauscher	40SDC00	Su richiesta / On request / Sur demande / Bajo solicitud / Auf Anfrage
Command Spa	40CMS00	600
Filtro a sabbia esterno / External sand filter / Filtre à sable externe / Filtro de arena externo / Externer Sandfilter	40FILS01	1.700
Kit Mantenimento Spa / Spa Maintenance Kit / Kit d'entretien Spa / Kit de mantenimiento Spa / Spa-Pflegekit	40KITMAN	320
Kit Pulizia Spa / Spa Cleaning Kit / Kit de nettoyage Spa / Kit de limpieza Spa / Spa-Reinigungsset	40KITPUL	120



Scopri i nostri sistemi di idromassaggio
 / Discover our hydromassage systems
 / Découvrez nos systèmes de hydromassage
 / Descubre nuestros sistemas de hidromasaje
 / Entdecken Sie unsere Hydromassage-Systeme



Scopri il funzionamento Microsilik®
 / Discover how Microsilik® works
 / Découvrez le fonctionnement de Microsilik®
 / Descubra el funcionamiento de Microsilik®
 / Entdecken Sie die Funktionsweise von Microsilik®

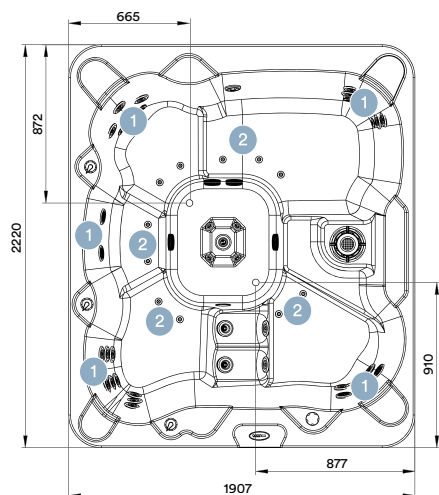

1 Whirlpool

2 Airpool

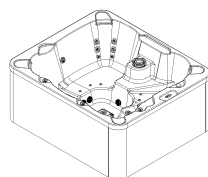

MASSAGGI /
 Massages / Massages /
 Masajes / Massagen

- Radici di Benessere
- Distensione
- Flusso Vitale
- Comfort
- Sostegno
- Mirato
- Avvolgente

Per le misure esterne considerare una tolleranza di ± 5mm
 For the external dimensions, allow a tolerance of ± 5 mm
 Pour les dimensions extérieures, prévoir une tolérance de ± 5 mm
 Para las medidas exteriores, considerar una tolerancia de ± 5 mm
 Für die Außenmaße ist eine Toleranz von ± 5 mm zu berücksichtigen

Privè 103

DESIGN // ALBATROS R&D



 221,5x179,5-h 94 cm

 800 lt | max

 230 kg

 x1
 x2
n° max

**Finiture / Finishes /
Finitions / Acabados /
Oberflächen**

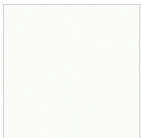

Molded White





**Pannelli Panels /
Panneaux / Paneles /
Pannele B-PLUS**



**Elegant Tea For
Two (TT)**

DOTAZIONI / FEATURES / ÉQUIPEMENTS / EQUIPAMIENTO / AUSSTATTUNG

PLUS

	Whirlpool Jets	36
	Bocchette / Nozzles / Buses / Boquillas / Düsen	JetPool
	Disinfezione con Sistema UV / UV Disinfection System / Système de désinfection UV / Sistema de desinfección UV / UV-Desinfektionssystem	✓
	Cromoterapia / Chromotherapy / Chromothérapie / Cromoterapia / Farbtherapie	✓
	Riscaldatore 3Kw / 3kW Heater / Chauffage 3kW / Calentador de 3kW / 3kW-Heizung	✓
	Pompe / Pumps / Pompes / Bombas / Pumpen	1 2speed
	Scarico semi-automatico / Semi-automatic Drain / Vidange semi-automatique / Drenaje semiautomático / Halbautomatischer Ablauf	✓
	Filtro a cartuccia / Cartridge Filter / Filtre à cartouche / Filtro de cartucho / Kartuschenfilter	✓
	Skimmer Flottante / Floating skimmer / Skimmer flottant / Skimmer flotante / Schwimmender Skimmer	✓
	Touch Display	✓

GREEN PLUS



ENERGY SAVING



MICROBAN

Molded White

Greytek

PRIVÈ 103

04PRB21 12.600

Copertura termica Thermal Cover / Couverture thermique / Cubierta térmica / Thermoabdeckung

40PRCT00 1.600

Optional



Pannelli / Panels / Panneaux /
Paneles / Panele + 0 cm



Scaletta / Access Ladder /
Échelle d'accès / Escalera de
acceso / Einstiegsleiter

Elegant Tea For Two (TT)

40PR4FTT

3.000

40PRSCTT

900

PRIVÈ
SPA

Optional

Codice

Micro Silk

40MCSK00

2.850

Scambiatore di Calore / Heat exchanger / Échangeur de chaleur / Intercambiador de calor / Wärmetauscher

40SDC00

Su richiesta / On request / Sur demande
/ Bajo solicitud / Auf Anfrage

Command Spa

40CMS00

600

Filtro a sabbia esterno / External sand filter / Filtre à sable externe / Filtro de arena externo / Externer Sandfilter

40FILS01

1.700

Kit Mantenimento Spa / Spa Maintenance Kit / Kit d'entretien Spa / Kit de mantenimiento Spa / Spa-Pflegekit

40KITMAN

320

Kit Pulizia Spa / Spa Cleaning Kit / Kit de nettoyage Spa / Kit de limpieza Spa / Spa-Reinigungsset

40KITPUL

120



Scopri i nostri sistemi di idromassaggio
/ Discover our hydromassage systems
/ Découvrez nos systèmes de hydromassage
/ Descubre nuestros sistemas de hidromasaje
/ Entdecken Sie unsere Hydromassage-Systeme



Scopri il funzionamento Microsilik®
/ Discover how Microsilik® works
/ Découvrez le fonctionnement de Microsilik®
/ Descubra el funcionamiento de Microsilik®
/ Entdecken Sie die Funktionsweise von Microsilik®

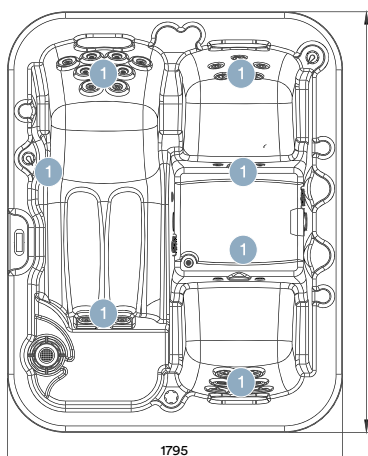

1 Whirlpool

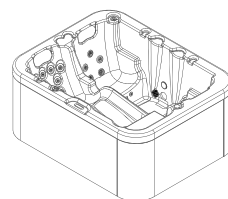

MASSAGGI /
Massages / Massages /
Masajes / Massagen

- Energia Totale**
- Vitalità**
- Distensione**

Per le misure esterne considerare una tolleranza di ± 5 mm
For the external dimensions, allow a tolerance of ± 5 mm
Pour les dimensions extérieures, prévoir une tolérance de ± 5 mm
Para las medidas exteriores, considerar una tolerancia de ± 5 mm
Für die Außenmaße ist eine Toleranz von ± 5 mm zu berücksichtigen

Beverly 356x266 h 95
Forever Ø 300 h 104
Kristal XL 300x234 h 97
Kristal L 236x190 h 92

Albatros

05

Minipiscine Overflow

OVERFLOW SPA



Beverly
pag. 66



Forever
pag. 68



Kristal XL
pag. 70



Kristal L
pag. 72

Beverly

DESIGN // ALBATROS R&D



 **356 x 266 - h 95 cm**

 **2490 lt | max**

 **2863 kg**



x7 | **n° max**



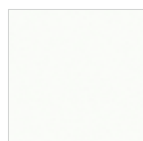



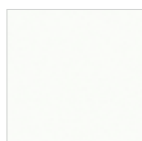





**Finiture / Finishes /
Finitions / Acabados /
Oberflächen**



**Sprayed Gloss
White**



**Sprayed Matt
White**

DOTAZIONI / FEATURES / ÉQUIPEMENTS / EQUIPAMIENTO / AUSSTATTUNG	BASE	COMPLETE
 Whirlpool Jets	16	16
 Airpool Jets	20	20
 Bocchette / Nozzles / Buses / Boquillas / Düsen	JetPool	JetPool
 Disinfezione con Sistema UV / UV Disinfection System / Système de désinfection UV / Sistema de desinfección UV / UV-Desinfektionssystem	-	✓
 Cromoterapia / Chromotherapy / Chromothérapie / Cromoterapia / Farbtherapie	-	✓
 Riscaldatore 6Kw / 6kW Heater / Chauffage 6kW / Calentador de 6kW / 6kW-Heizung	-	✓
 Pompe / Pumps / Pompes / Bombas / Pumpen	-	2
 Carico automatico / Automatic filling system / Système de remplissage automatique / Sistema de llenado automático / Automatisches Befüllsystem	-	✓
 Filtro a sabbia / Sand Filter / Filtre à sable / Filtro de arena / Sandfilter	-	✓
 Pulsanti Piezoelettrici	-	2
 Overflow	✓	✓
 Vasca di compenso esterna da 2000lt / 2000-litre external compensation tank / Réservoir de compensation externe de 2000 litres / Depósito de compensación externo de 2000 litros / Externer Ausgleichsbehälter mit 2000 l Fassungsvermögen	-	✓

GREEN PLUS



GREEN SPA



MICROBAN

	Sprayed White	Greytek
BEVERLY BASE	Glossy 08BEB380B	26.900
	Matt 08BEB380M	25.600
BEVERLY COMPLETE	Glossy 08BEC380B	48.200
	Matt 08BEC380M	46.900
Copertura termica Thermal Cover / Couverture thermique / Cubierta térmica / Thermoabdeckung		40BECT00 4.000

Optional	Codice	
Scambiatore di Calore / Heat exchanger / Échangeur de chaleur / Intercambiador de calor / Wärmetauscher	40SDC00	Su richiesta / On request / Sur demande / Bajo solicitud / Auf Anfrage
Kit Mantenimento Spa / Spa Maintenance Kit / Kit d'entretien Spa / Kit de mantenimiento Spa / Spa-Pflegekit	40KITMAN	320
Kit Pulizia Spa / Spa Cleaning Kit / Kit de nettoyage Spa / Kit de limpieza Spa / Spa-Reinigungsset	40KITPUL	120

OVERFLOW SPA



Scopri i nostri sistemi di idromassaggio
 / Discover our hydromassage systems
 / Découvrez nos systèmes de hydromassage
 / Descubre nuestros sistemas de hidromasaje
 / Entdecken Sie unsere Hydromassage-Systeme

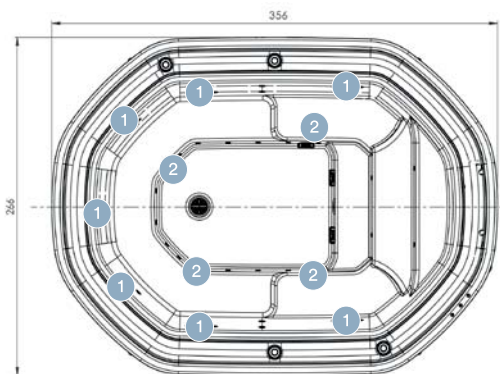

1 Whirlpool

2 Airpool

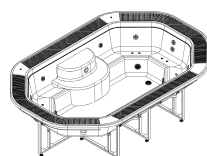

MASSAGGI /
 Massages / Massages /
 Masajes / Massagen

 **Benessere Mirato**

 **Serenità**

Per le misure esterne considerare una tolleranza di ± 5 mm
 For the external dimensions, allow a tolerance of ± 5 mm
 Pour les dimensions extérieures, prévoir une tolérance de ± 5 mm
 Para las medidas exteriores, considerar una tolerancia de ± 5 mm
 Für die Außenmaße ist eine Toleranz von ± 5 mm zu berücksichtigen

Forever

DESIGN // ALBATROS R&D



 Ø 300 cm - h 104 cm

 2290 lt | max

 **330 kg**

 x9 | n° max



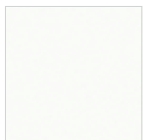



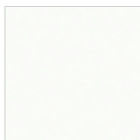





**Finiture / Finishes /
Finitions / Acabados /
Oberflächen**



**Sprayed Gloss
White**



**Sprayed Matt
White**

DOTAZIONI / FEATURES / ÉQUIPEMENTS / EQUIPAMIENTO / AUSSTATTUNG	BASE	COMPLETE
 Whirlpool Jets	18	18
 Airpool Jets	18	18
 Bocchette / Nozzles / Buses / Boquillas / Düsen	JetPool	JetPool
 Disinfezione con Sistema UV / UV Disinfection System / Système de désinfection UV / Sistema de desinfección UV / UV-Desinfektionssystem	-	✓
 Cromoterapia / Chromotherapy / Chromothérapie / Cromoterapia / Farbtherapie	-	✓
 Riscaldatore 6Kw / 6kW Heater / Chauffage 6kW / Calentador de 6kW / 6kW-Heizung	-	✓
 Pompe / Pumps / Pompes / Bombas / Pumpen	-	2
 Carico automatico / Automatic filling system / Système de remplissage automatique / Sistema de llenado automático / Automatisches Befüllsystem	-	✓
 Filtro a sabbia / Sand Filter / Filtre à sable / Filtro de arena / Sandfilter	-	✓
 Pulsanti Piezoelettrici	-	2
 Overflow	✓	✓
 Vasca di compenso esterna da 2000lt / 2000-litre external compensation tank / Réservoir de compensation externe de 2000 litres / Depósito de compensación externo de 2000 litros / Externer Ausgleichsbehälter mit 2000 l Fassungsvermögen	-	✓

GREEN PLUS



GREEN SPA



MICROBAN

	Sprayed White	Greytek
FOREVER BASE	Glossy 08FOB230B	22.500
	Matt 08FOB230M	21.200
FOREVER COMPLETE	Glossy 08FOC230B	43.800
	Matt 08FOC230M	42.500
Copertura termica Thermal Cover / Couverture thermique / Cubierta térmica / Thermoabdeckung		40FOCT00 3.900

Optional	Codice	
Scambiatore di Calore / Heat exchanger / Échangeur de chaleur / Intercambiador de calor / Wärmetauscher	40SDC00	Su richiesta / On request / Sur demande / Bajo solicitud / Auf Anfrage
Kit Mantenimento Spa / Spa Maintenance Kit / Kit d'entretien Spa / Kit de mantenimiento Spa / Spa-Pflegekit	40KITMAN	320
Kit Pulizia Spa / Spa Cleaning Kit / Kit de nettoyage Spa / Kit de limpieza Spa / Spa-Reinigungsset	40KITPUL	120

OVERFLOW SPA



Scopri i nostri sistemi di idromassaggio
 / Discover our hydromassage systems
 / Découvrez nos systèmes de hydromassage
 / Descubre nuestros sistemas de hidromasaje
 / Entdecken Sie unsere Hydromassage-Systeme

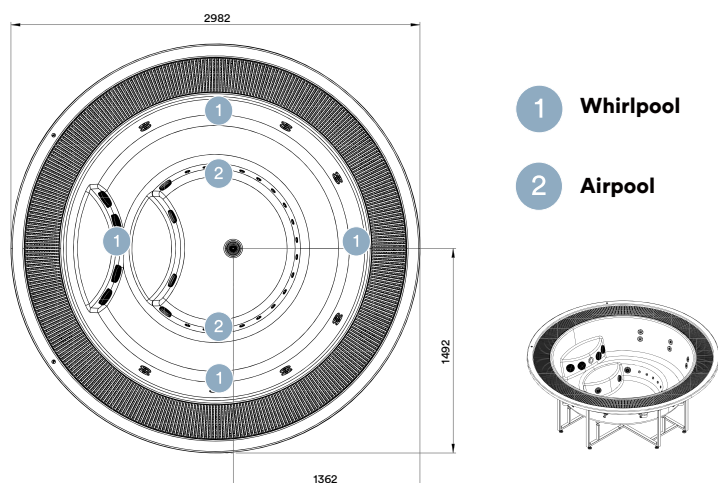

MASSAGGI /
 Massages / Massages /
 Masajes / Massagen

 **Benessere Mirato**

Per le misure esterne considerare una tolleranza di ± 5 mm
 For the external dimensions, allow a tolerance of ± 5 mm
 Pour les dimensions extérieures, prévoir une tolérance de ± 5 mm
 Para las medidas exteriores, considerar una tolerancia de ± 5 mm
 Für die Außenmaße ist eine Toleranz von ± 5 mm zu berücksichtigen

Kristal XL

DESIGN // ALBATROS R&D



300 x 234 - h 97 cm

1900 lt | max

550 kg

x1
 x6
n° max

Finiture / Finishes / Finitions / Acabados / Oberflächen

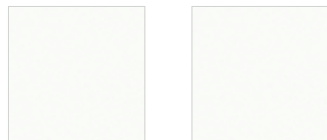

Sprayed Gloss White

Sprayed Matt White

Pannelli Panels / Panneaux / Paneles / Panele B-PLUS



Graphite (GP)



RAL

DOTAZIONI / FEATURES / ÉQUIPEMENTS / EQUIPAMIENTO / AUSSTATTUNG

	BASE	STANDARD	PLUS
Whirlpool Jets	33	33	33
Bocchette / Nozzles / Buses / Boquillas / Düsen	FilJet	FilJet	FilJet
Disinfezione con Sistema UV / UV Disinfection System / Système de désinfection UV / Sistema de desinfección UV / UV-Desinfektionssystem	-	-	✓
Cromoterapia / Chromotherapy / Chromothérapie / Cromoterapia / Farbtherapie	-	-	✓
Filtro a cartuccia / Cartridge Filter / Filtre à cartouche / Filtro de cartucho / Kartuschenfilter	-	✓	✓
Riscaldatore 3Kw / 3kW Heater / Chauffage 3kW / Calentador de 3kW / 3kW-Heizung	-	✓	✓
Pompe / Pumps / Pompes / Bombas / Pumpen	-	1 2speed	1
Display Touch	-	✓	✓
Scarico semi-automatico / Semi-automatic Drain / Vidange semi-automatique / Drenaje semiautomático / Halbautomatischer Ablauf	-	✓	✓
Carico automatico / Automatic filling system / Système de remplissage automatique / Sistema de llenado automático / Automatisches Befüllsystem	-	✓	✓
Pompa Silence Spa / Silence Spa pump / Pompe Silence Spa / Bomba Silence Spa / Silence Spa Pumpe	-	-	1
Overflow	✓	✓	✓
Sottofondo stabilizzatore / Stabilizing sub-base / Sous-fond stabilisateur / Subbase estabilizadora / Stabilisierende Unterbau	✓	✓	✓
Vasca di compenso / Compensating tank / Réservoir de compensation / Depósito de compensación / Ausgleichsbehälter	-	✓	✓

GREEN PLUS



GREEN SPA



ENERGY SAVING



MICROBAN



SILENCE SPA



CONTROL MYSPA

	Sprayed Gloss White		Sprayed Matt White		Greytek
KRISTAL XL BASE	04KX18BSBN	33.400	04KX18BSBL	34.500	
KRISTAL XL STANDARD	04KX18STBN	39.200	04KX18STBL	40.300	
KRISTAL XL PLUS	04KX18PLBN	40.400	04KX18PLBL	41.000	
Copertura termica Thermal Cover / Couverture thermique / Cubierta térmica / Thermoabdeckung					40KXCT00 2.000

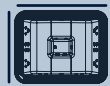

Pannelli / Panels / Panneaux / Paneles / Panele + 0 cm

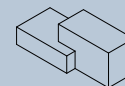

Scaletta / Access Ladder / Échelle d'accès / Escalera de acceso / Einstiegsleiter

Graphite	40THPRGP	4.200	40XXSCGP	1.800
RAL	40THPR**	5.900	40XXSC**	1.800

**Il codice verrà comunicato dopo la scelta del colore / The code will be provided after the color selection / Le code sera communiqué après le choix de la couleur / El código se comunicará después de la elección del color / Der Code wird nach der Farbauswahl mitgeteilt

Optional	Codice	
Scambiatore di Calore / Heat exchanger / Échangeur de chaleur / Intercambiador de calor / Wärmetauscher	40SDC00	Su richiesta / On request / Sur demande / Bajo solicitud / Auf Anfrage
Command Spa	40CMS00	600
Filtro a sabbia / sand filter / Filtre à sable / Filtro de arena / Sandfilter	40FILS02	1.400
Kit Mantenimento Spa / Spa Maintenance Kit / Kit d'entretien Spa / Kit de mantenimiento Spa / Spa-Pflegekit	40KITMAN	320
Kit Pulizia Spa / Spa Cleaning Kit / Kit de nettoyage Spa / Kit de limpieza Spa / Spa-Reinigungsset	40KITPUL	120



Scopri i nostri sistemi di idromassaggio
 / Discover our hydromassage systems
 / Découvrez nos systèmes de hydromassage
 / Descubre nuestros sistemas de hidromasaje
 / Entdecken Sie unsere Hydromassage-Systeme

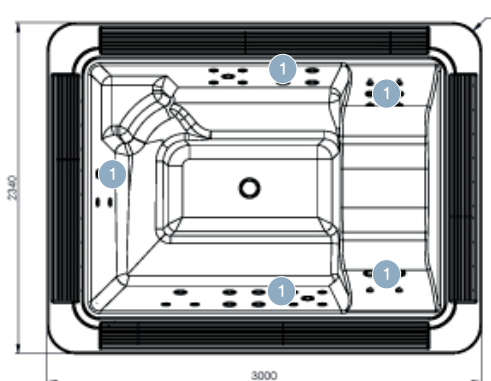

1 Whirlpool

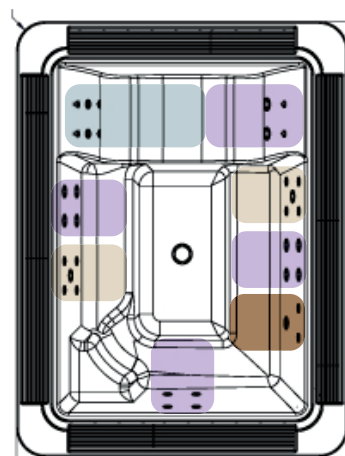

MASSAGGI /
 Massages / Massages /
 Masajes / Massagen

- Respiro profondo
- Armonia
- Sospiro
- Radici Forti

Per le misure esterne considerare una tolleranza di ± 5mm
 For the external dimensions, allow a tolerance of ± 5 mm
 Pour les dimensions extérieures, prévoir une tolérance de ± 5 mm
 Para las medidas exteriores, considerar una tolerancia de ± 5 mm
 Für die Außenmaße ist eine Toleranz von ± 5 mm zu berücksichtigen

Kristal L

DESIGN // ALBATROS R&D

Incassata / Built-in / Encastrable /
Emportada / Einbau



236 x 190 - h 92 cm

1200 lt | max

350 kg

x2
 x2
n° max

**Finiture / Finishes /
Finitions / Acabados /
Oberflächen**

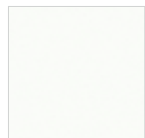

Molded White

**Pannelli Panels /
Panneaux / Paneles /
Panele B-PLUS**



Graphite (GP)



RAL

DOTAZIONI / FEATURES / ÉQUIPEMENTS / EQUIPAMIENTO / AUSSTATTUNG

	BASE	STANDARD	PLUS
Whirlpool Jets	32	32	32
Bocchette / Nozzles / Buses / Boquillas / Düsen	FilJet	FilJet	FilJet
Disinfezione con Sistema UV / UV Disinfection System / Système de désinfection UV / Sistema de desinfección UV / UV-Desinfektionssystem	-	-	✓
Cromoterapia / Chromotherapy / Chromothérapie / Cromoterapia / Farbtherapie	-	-	✓
Led perimetrale / perimeter Led / Led périmétrique / Led perimetral / Begrenzungs-Led	-	✓	✓
Riscaldatore 3Kw / 3kW Heater / Chauffage 3kW / Calentador de 3kW / 3kW-Heizung	-	✓	✓
Pompe / Pumps / Pompes / Bombas / Pumpen	-	1 2speed	1
Pompa Silence Spa / Silence Spa pump / Pompe Silence Spa / Bomba Silence Spa / Silence Spa Pumpe	-	-	1
Scarico semi-automatico / Semi-automatic Drain / Vidange semi-automatique / Drenaje semiautomático / Halbautomatischer Ablauf	-	✓	✓
Carico automatico / Automatic filling system / Système de remplissage automatique / Sistema de llenado automático / Automatisches Befüllsystem	-	✓	✓
Filtro a cartuccia / Cartridge Filter / Filtre à cartouche / Filtro de cartucho / Kartuschenfilter	-	✓	✓
Overflow	✓	✓	✓
Vasca di compenso / Compensating tank / Réservoir de compensation / Depósito de compensación / Ausgleichbehälter	-	✓	✓
Sottofondo stabilizzatore / Stabilizing sub-base / Sous-fond stabilisateur / Subbase estabilizadora / Stabilisierende Unterbau	✓	✓	✓
Touch Display	✓	✓	✓

GREEN PLUS



ENERGY SAVING



MICROBAN



SILENCE SPA



CONTROL MYSPA

	Molded White	Greytek
KRISTAL L BASE	04KR18BSBN	12.300
KRISTAL L STANDARD	04KR18STBN	23.000
KRISTAL L PLUS	04KR18PLBN	25.200
Copertura termica Thermal Cover / Couverture thermique / Cubierta térmica / Thermoabdeckung	40KRCT00	1.700

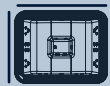

Pannelli / Panels / Panneaux /
Paneles / Paneele + 0 cm

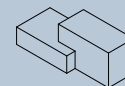

Scaletta / Access Ladder /
Échelle d'accès / Escalera de
acceso / Einstiegsleiter

Graphite	40THPRGP	3.400	40XXSCGP	1.800
RAL	40THPR**	4.800	40XXSC**	1.800

**Il codice verrà comunicato dopo la scelta del colore / The code will be provided after the color selection / Le code sera communiqué après le choix de la couleur / El código se comunicará después de la elección del color / Der Code wird nach der Farbauswahl mitgeteilt

Optional	Codice	
Scambiatore di Calore / Heat exchanger / Échangeur de chaleur / Intercambiador de calor / Wärmetauscher	40SDC00	Su richiesta / On request / Sur demande / Bajo solicitud / Auf Anfrage
Command Spa	40CMS00	600
Filtro a sabbia esterno / External sand filter / Filtre à sable externe / Filtro de arena externo / Externer Sandfilter	40FILS01	1.700
Kit Mantenimento Spa / Spa Maintenance Kit / Kit d'entretien Spa / Kit de mantenimiento Spa / Spa-Pflegekit	40KITMAN	320
Kit Pulizia Spa / Spa Cleaning Kit / Kit de nettoyage Spa / Kit de limpieza Spa / Spa-Reinigungsset	40KITPUL	120



Scopri i nostri sistemi di idromassaggio
/ Discover our hydromassage systems
/ Découvrez nos systèmes de hydromassage
/ Descubre nuestros sistemas de hidromasaje
/ Entdecken Sie unsere Hydromassage-Systeme

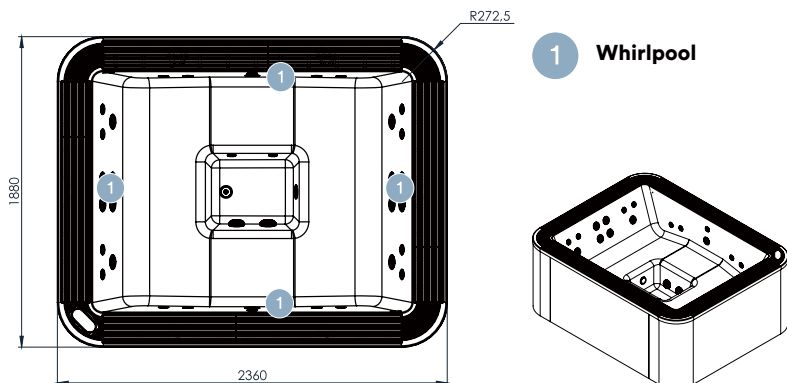

1 Whirlpool

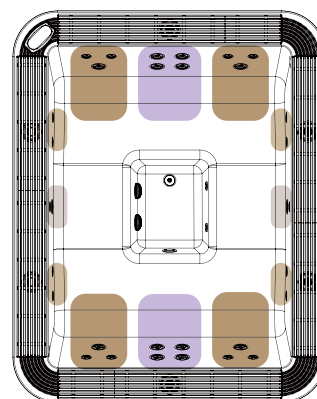

MASSAGGI /
Massages / Massages /
Masajes / Massagen

- Respiro profondo**
- Sostegno Avvolgente**
- Radici Forti**
- Ali di Energia**

Per le misure esterne considerare una tolleranza di ± 5 mm
For the external dimensions, allow a tolerance of ± 5 mm
Pour les dimensions extérieures, prévoir une tolérance de ± 5 mm
Para las medidas exteriores, considerar una tolerancia de ± 5 mm
Für die Außenmaße ist eine Toleranz von ± 5 mm zu berücksichtigen

Harry Swim 1 600x230 h 138

Harry Swim 2 500x230 h 138

Harry Swim 3 400x230 h 138

Albatros

06

Minipiscine Swim

SWIM SPA



Harry Swim 1
pag. 76



Harry Swim 2
pag. 78



Harry Swim 3
pag. 80

Harry Swim I

DESIGN // ALBATROS R&D



600 x 230 - h 138

1000 (A) 6000 (B) lt

8500 kg

x1
 x2
 x1
 x1
 n° max

Finiture / Finishes / Finitions / Acabados / Oberflächen

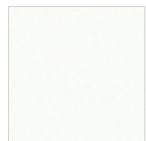

Sprayed White

Pannelli Panels / Panneaux / Paneles / Panele B-PLUS



Mokka

DOTAZIONI / FEATURES / ÉQUIPEMENTS / EQUIPAMIENTO / AUSSTATTUNG

PLUS

	Turbo Jets nuoto controcorrente	5
	Whirpool Jets A	30
	Whirpool Jets B	12
	Fontane d'acqua B	3
	Disinfezione con Sistema UV / UV Disinfection System / Système de désinfection UV / Sistema de desinfección UV / UV-Desinfektionssystem	✓
	Led	✓
	Filtro a cartuccia / Cartridge Filter / Filtre à cartouche / Filtro de cartucho / Kartuschenfilter	✓
	Riscaldatore 3Kw / 3kW Heater / Chauffage 3kW / Calentador de 3kW / 3kW-Heizung	✓
	Pompe / Pumps / Pompes / Bombas / Pumpen	3
	Skimmer Flottante / Floating skimmer / Skimmer flottant / Skimmer flotante / Schwimmender Skimmer	

GREEN PLUS



GREEN SPA



ENERGY SAVING



MICROBAN

Sprayed White

HARRY SWIM 1
SPA

09H1B300 80.900

HARRY SWIM 1 + PACK

SPA + Copertura termica + Pannelli Perimetrali / Spa + thermal cover + perimeter panels
/ Spa + couverture thermique + panneaux périmétraux / Spa + cubierta térmica + paneles perimetrales / Spa + Thermoabdeckung + Umfangspaneele

09HAB300 84.900

Optional

	Codice	
Poggiatesta / Headrest / Appuie-tête / Reposacabezas / Kopfstütze	40HSCS00	270
Scambiatore di Calore / Heat exchanger / Échangeur de chaleur / Intercambiador de calor / Wärmetauscher	40SDC00	Su richiesta / On request / Sur demande / Bajo solicitud / Auf Anfrage
Kit Mantenimento Spa / Spa Maintenance Kit / Kit d'entretien Spa / Kit de mantenimiento Spa / Spa-Pflegekit	40KITMAN	320
Kit Pulizia Spa / Spa Cleaning Kit / Kit de nettoyage Spa / Kit de limpieza Spa / Spa-Reinigungsset	40KITPUL	120
Acquabike	40HAAQ00	3.400
Kit audio Bluetooth / Bluetooth audio kit / Kit audio Bluetooth / Kit de audio Bluetooth / Bluetooth-Audio-Kit	40KITPUL	3.900

SWIM
SPA



Scopri i nostri sistemi di idromassaggio
/ Discover our hydromassage systems
/ Découvrez nos systèmes de hydromassage
/ Descubre nuestros sistemas de hidromasaje
/ Entdecken Sie unsere Hydromassage-Systeme

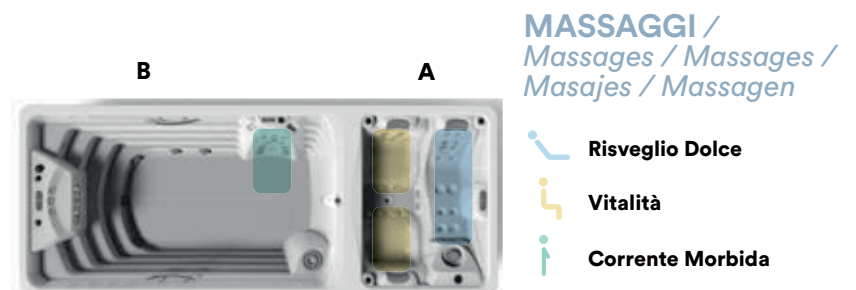
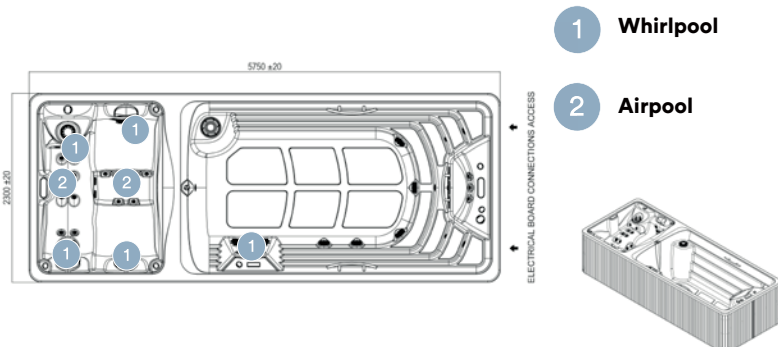

Harry Swim 2

DESIGN // ALBATROS R&D



 500 x 230 - h 138

 8500 | lt

 1170 kg

 x1
 x2
 x1
 n° max

Finiture / Finishes / Finitions / Acabados / Oberflächen

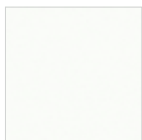

Molded White

Pannelli Panels / Panneaux / Paneles / Paneele B-PLUS



DOTAZIONI / FEATURES / ÉQUIPEMENTS / EQUIPAMIENTO / AUSSTATTUNG

PLUS

	Turbo Jets nuoto controcorrente	5
	Whirpool Jets	27
	Cascata	1
	Fontane d'acqua B	3
	Disinfezione con Sistema UV / UV Disinfection System / Système de désinfection UV / Sistema de desinfección UV / UV-Desinfektionssystem	✓
	Led	✓
	Filtro a cartuccia / Cartridge Filter / Filtre à cartouche / Filtro de cartucho / Kartuschenfilter	✓
	Riscaldatore 3Kw / 3kW Heater / Chauffage 3kW / Calentador de 3kW / 3kW-Heizung	✓
	Pompe / Pumps / Pompes / Bombas / Pumpen	3
	Skimmer Flottante / Floating skimmer / Skimmer flottant / Skimmer flotante / Schwimmender Skimmer	

GREEN PLUS



Sprayed White

HARRY SWIM 2
SPA

09H2B300 63.400

HARRY SWIM 2 + PACK

SPA + Copertura termica + Pannelli Perimetrali / Spa + thermal cover + perimeter panels
/ Spa + couverture thermique + panneaux périmétraux / Spa + cubierta térmica + paneles perimetrales / Spa + Thermoabdeckung + Umfangspaneele

09HAB500 66.600

Optional

	Codice	
Poggiatesta / Headrest / Appuie-tête / Reposacabezas / Kopfstütze	40HSCS00	270
Scambiatore di Calore / Heat exchanger / Échangeur de chaleur / Intercambiador de calor / Wärmetauscher	40SDC00	Su richiesta / On request / Sur demande / Bajo solicitud / Auf Anfrage
Kit Mantenimento Spa / Spa Maintenance Kit / Kit d'entretien Spa / Kit de mantenimiento Spa / Spa-Pflegekit	40KITMAN	320
Kit Pulizia Spa / Spa Cleaning Kit / Kit de nettoyage Spa / Kit de limpieza Spa / Spa-Reinigungsset	40KITPUL	120
Acquabike	40HAAQ00	3.400
Kit audio Bluetooth / Bluetooth audio kit / Kit audio Bluetooth / Kit de audio Bluetooth / Bluetooth-Audio-Kit	40KITPUL	3.900

SWIM
SPA



Scopri i nostri sistemi di idromassaggio
/ Discover our hydromassage systems
/ Découvrez nos systèmes de hydromassage
/ Descubre nuestros sistemas de hidromasaje
/ Entdecken Sie unsere Hydromassage-Systeme

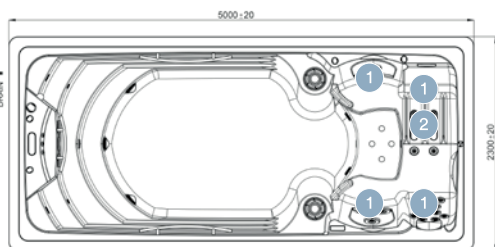

1 Whirlpool

2 Airpool

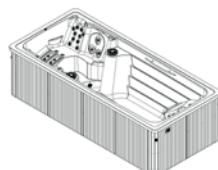

MASSAGGI /
Massages / Massages /
Masajes / Massagen

- Distensione
- Flusso Vitale
- Risveglio Dolce

Harry Swim 3

DESIGN // ALBATROS R&D



 **400 x 230 - h 138**

 **6000 | lt**

 **1150 kg**

 x1 | **n° max**
 x1

Finiture / Finishes / Finitions / Acabados / Oberflächen

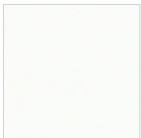

Molded White

Pannelli Panels / Panneaux / Paneles / Panele B-PLUS



Mokka

DOTAZIONI / FEATURES / ÉQUIPEMENTS / EQUIPAMIENTO / AUSSTATTUNG

PLUS

	Turbo Jets nuoto controcorrente	5
	Whirpool Jets	16
	Fontane d'acqua B	3
	Disinfezione con Sistema UV / UV Disinfection System / Système de désinfection UV / Sistema de desinfección UV / UV-Desinfektionssystem	✓
	Led	✓
	Filtro a cartuccia / Cartridge Filter / Filtre à cartouche / Filtro de cartucho / Kartuschenfilter	✓
	Riscaldatore 3Kw / 3kW Heater / Chauffage 3kW / Calentador de 3kW / 3kW-Heizung	✓
	Pompe / Pumps / Pompes / Bombas / Pumpen	3
	Skimmer Flottante / Floating skimmer / Skimmer flottant / Skimmer flotante / Schwimmender Skimmer	

GREEN PLUS



GREEN SPA



ENERGY SAVING



MICROBAN

Sprayed White

HARRY SWIM 3
SPA

09H3B300 55.300

HARRY SWIM 3 + PACK

SPA + Copertura termica + Pannelli Perimetrali / Spa + thermal cover + perimeter panels
/ Spa + couverture thermique + panneaux périmétraux / Spa + cubierta térmica + paneles perimetrales / Spa + Thermoabdeckung + Umfangspaneele

09HAB400 57.800

Optional

	Codice	
Poggiatesta / Headrest / Appuie-tête / Reposacabezas / Kopfstütze	40HSCS00	270
Scambiatore di Calore / Heat exchanger / Échangeur de chaleur / Intercambiador de calor / Wärmetauscher	40SDC00	Su richiesta / On request / Sur demande / Bajo solicitud / Auf Anfrage
Kit Mantenimento Spa / Spa Maintenance Kit / Kit d'entretien Spa / Kit de mantenimiento Spa / Spa-Pflegekit	40KITMAN	320
Kit Pulizia Spa / Spa Cleaning Kit / Kit de nettoyage Spa / Kit de limpieza Spa / Spa-Reinigungsset	40KITPUL	120
Acquabike	40HAAQ00	3.400
Kit audio Bluetooth / Bluetooth audio kit / Kit audio Bluetooth / Kit de audio Bluetooth / Bluetooth-Audio-Kit	40KITPUL	3.900

SWIM
SPA



Scopri i nostri sistemi di idromassaggio
/ Discover our hydromassage systems
/ Découvrez nos systèmes de hydromassage
/ Descubre nuestros sistemas de hidromasaje
/ Entdecken Sie unsere Hydromassage-Systeme

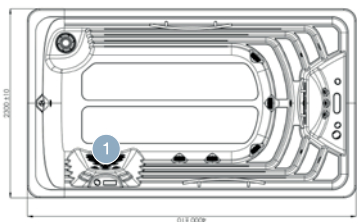

1 Whirlpool

2 Airpool

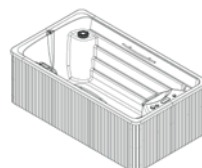

MASSAGGI /
Massages / Massages /
Masajes / Massagen

 **Corrente Morbida**

Albatros
07

Accessori

ACCESSORIES



Scalette / Steps
Échelles / Escaleras
Einstiegsleitern

pag. 84



**Coperture / Covers /
Couvertures / Cubiertas**
Abdeckung

pag. 86



Kit Pulizia / Cleaning kit
/ Kit de nettoyage
/ Kit de limpieza / Reinigungsset

pag. 88



Kit Mantenimento
/ Maintenance kit
/ Kit d'entretien
/ Kit de mantenimiento
/ Wartungsset

pag. 88



Poggiatesta-Sedute
/ Headrests - Seats
/ Appuie-tête - Assises
/ Reposacabezas - Asientos
/ Kopfstützen - Sitze

pag. 89

Scalette per Minipiscina

/ Steps for mini pool / Échelles pour mini-piscine / Escaleras para minipiscina / Einstiegsleitern für Minipool

→ Thea, Soreha, Oniris, Kristal L, Kristal XL, Modula

Vista frontale
/ Front view / Vue frontale / Vista frontal / Vorderansicht

Vista laterale
/ Side view / Vue latérale / Vista lateral / Seitenansicht

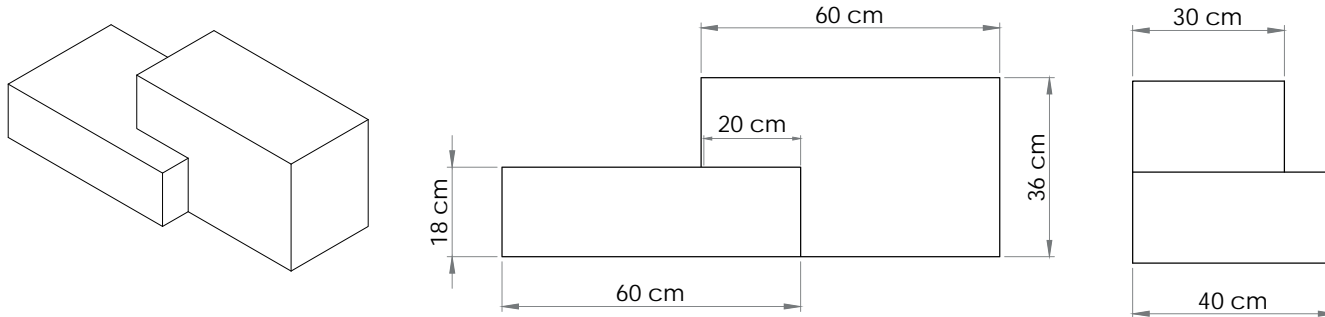

→ **Disponibile in 4 Colori B-PLUS**
/ Available in 4 finishes / Disponible en 4 finitions / Disponible en 4 acabados / In 4 Ausführungen erhältlich



	Scaletta / Access Ladder / Échelle d'accès / Escalera de acceso / Einstiegsleiter	
Elegant Tea For Two (TT)	40XXSCTT	2.000
Tortona Natural (TN)	40XXSCTN	2.000
Graphite (GP)	40XXSCGP	2.000
Kashmir (KS)	40XXSCKS	2.000



→ Privè 103, Privè 206, Privè 306, Privè 405

Vista frontale
/ Front view / Vue frontale / Vista frontal / Vorderansicht

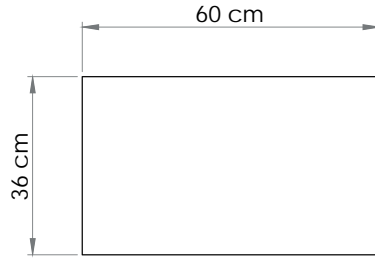
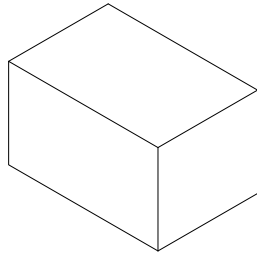

Vista laterale
/ Side view / Vue latérale / Vista lateral / Seitenansicht

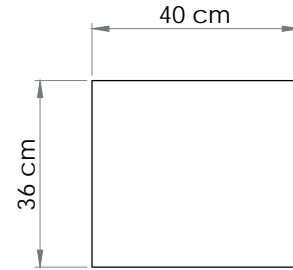

→ **Finitura Disponibile B-PLUS**
/ Available finish / Finition disponible / Acabado disponible / Verfügbare Ausführung



Elegant Tea For Two (TT)

Scaletta / Access Ladder / Échelle d'accès / Escalera de acceso / Einstiegsleiter

Elegant Tea For Two (TT)

40PRSCTT

900

→ Privè R07

Vista frontale
/ Front view / Vue frontale / Vista frontal / Vorderansicht

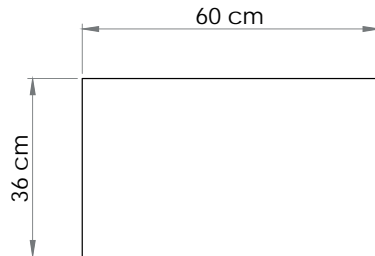
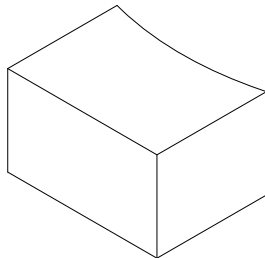

Vista laterale
/ Side view / Vue latérale / Vista lateral / Seitenansicht

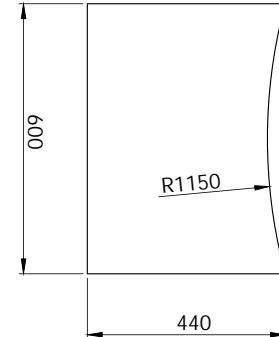

→ **Finitura Disponibile B-PLUS**
/ Available finish / Finition disponible / Acabado disponible / Verfügbare Ausführung



Elegant Tea For Two (TT)

Scaletta / Access Ladder / Échelle d'accès / Escalera de acceso / Einstiegsleiter

Elegant Tea For Two (TT)

40PASCTT

1.200

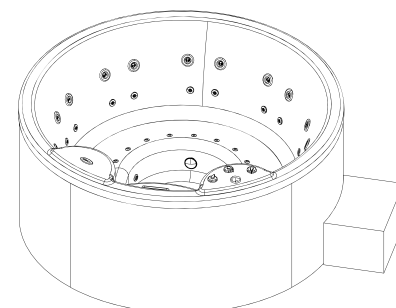

Coperture Termiche

/ Thermal covers / Couvertures thermiques / Cubiertas térmicas / Thermoabdeckungen

→ Modula, Kellia, Thea, Soreha, Oniris, Kristal L, Kristal XL, Privè 103, Privè 206, Privè 306, Privè 405

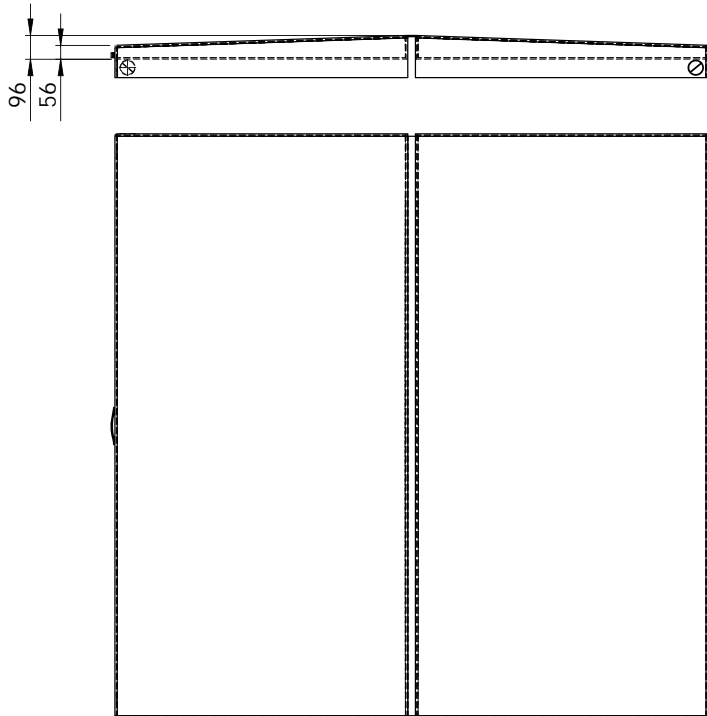

→ **Finitura Disponibile**
/ Available finish / Finition disponible / Acabado disponible / Verfügbare Ausführung

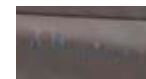

Greytek

→ **Ethos**

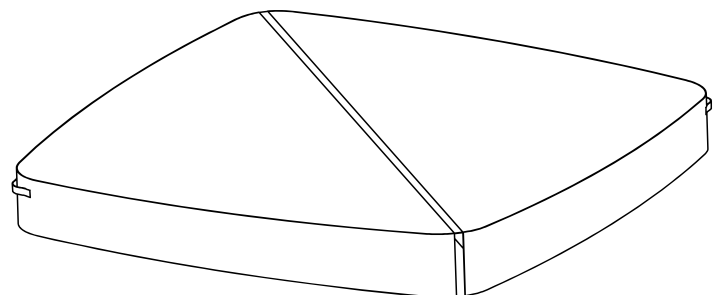
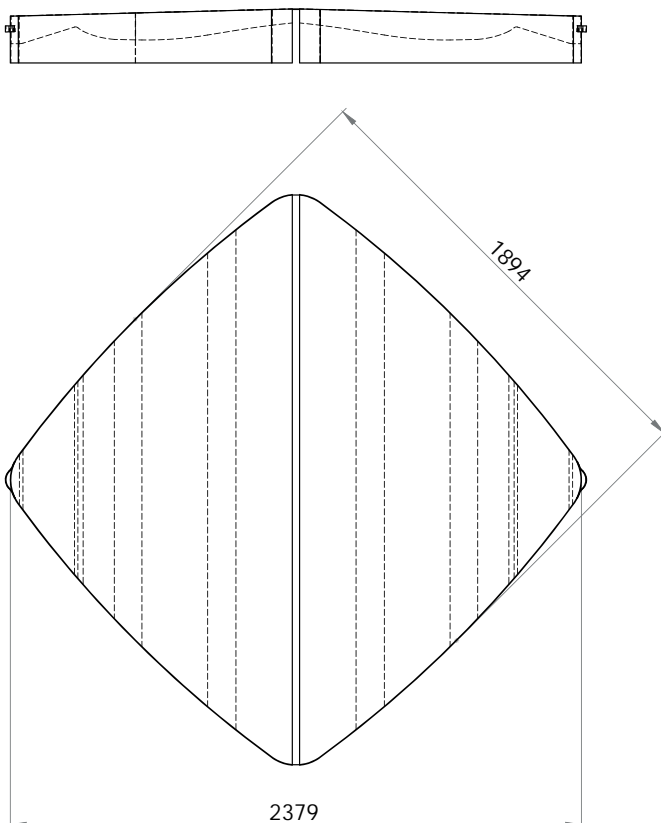

→ **Finitura Disponibile**
/ Available finish / Finition disponible / Acabado disponible / Verfügbare Ausführung

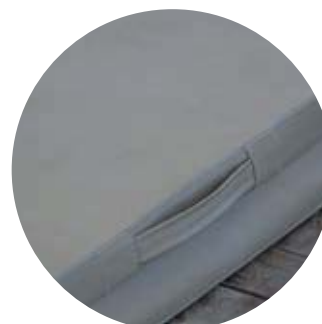

Greytek

→ Privè R07

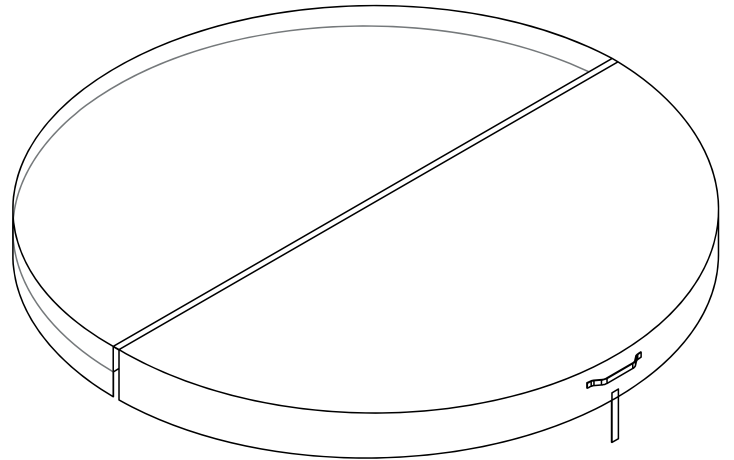
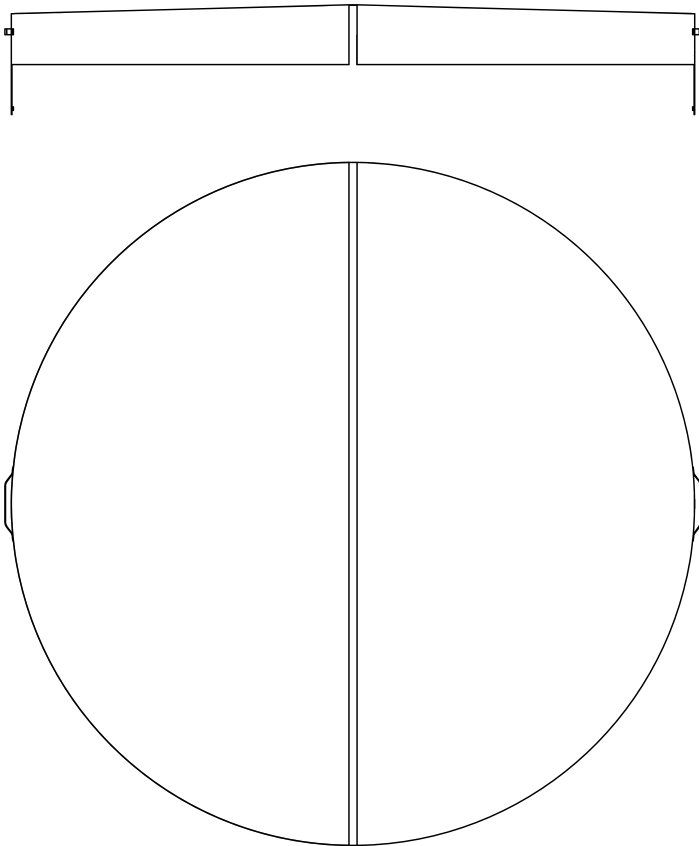

→ **Finitura Disponibile**
/ Available finish / Finition disponible / Acabado disponible / Verfügbare Ausführung



Greytek

→ Syraka

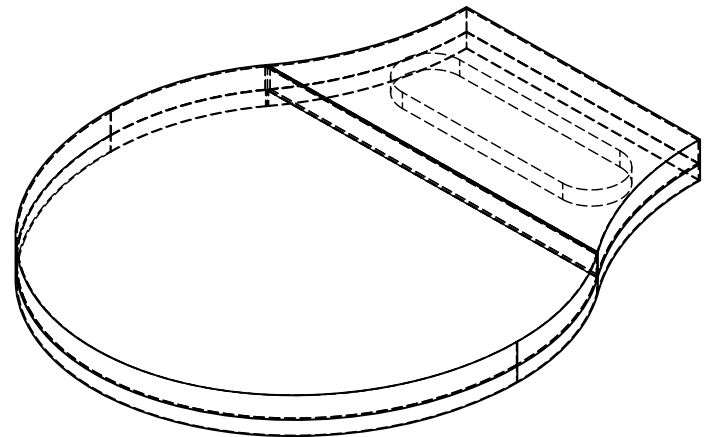
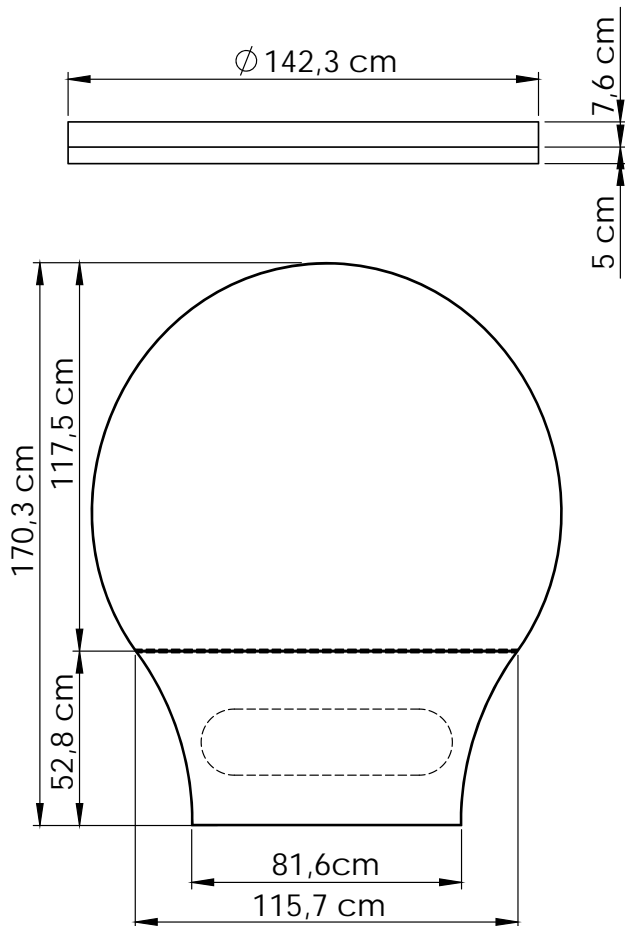

→ **Finitura Disponibile**
/ Available finish / Finition disponible / Acabado disponible / Verfügbare Ausführung

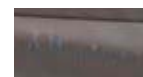

Greytek

Kit Pulizia

/ Cleaning kit / Kit de nettoyage / Kit de limpieza / Reinigungsset



FILTRO-CAL LQ
Detergente per la pulizia dei filtri.
/ Filter cleaning detergent / Détergent pour le nettoyage des filtres / Detergente para la limpieza de los filtros / Reinigungsmittel für die Filterreinigung.



ALKANET
Rimuove residui oleosi e previene la formazione di schiuma.
/ Removes oily residues and prevents foam formation / Élimine les résidus huileux et prévient la formation de mousse / Elimina residuos oleosos y previene la formación de espuma / Entfernt ölhaltige Rückstände und verhindert Schaumbildung.



OXIGEN ATTIVO GR
Ossidante per il trattamento e il mantenimento dell'acqua della spa.
/ Oxidizing agent for spa water treatment and maintenance / Oxydant pour le traitement et l'entretien de l'eau de la spa / Oxidante para el tratamiento y el mantenimiento del agua del spa / Oxidationsmittel für die Behandlung und Pflege des Spa-Wassers.



DISINCROSTANTE
Pulisce a fondo superfici e circuito della spa.
/ Deeply cleans spa surfaces and the circulation system / Nettoie en profondeur les surfaces et le circuit de la spa / Limpia en profundidad las superficies y el circuito del spa / Reinigt gründlich die Oberflächen und den Spa-Kreislauf.

Kit Mantenimento

/ Maintenance kit / Kit d'entretien / Kit de mantenimiento / Wartungsset



ZERO PROBLEM
Mantiene l'acqua limpida e stabile.
/ Keeps the water clear and stable / Maintient l'eau claire et stable / Mantiene el agua clara y estable / Hält das Wasser klar e stabil.



LAPIZZANTE
Trattamento per la pulizia del circuito spa.
/ Treatment for cleaning the spa circulation system / Traitement pour le nettoyage du circuit de la spa / Tratamiento para la limpieza del circuito del spa / Behandlung zur Reinigung des Spa-Kreislaufs.



BROMO PAST. 20
Disinfettante a base di bromo per spa e minipiscine.
/ Bromine-based disinfectant for spas and mini pools / Désinfectant à base de brome pour spas et mini-piscines / Desinfectante a base de bromo para spas y minipiscinas / Brombasierter Desinfektionsmittel für Spas und Minipools.



PH-MINUS GR
Abbassa il valore del pH dell'acqua.
/ Lowers the pH level of the water / Abaisse la valeur du pH de l'eau / Reduce el valor del pH del agua / Senkt den pH-Wert des Wassers.



KIT ANALISI ACQUA
Permette il controllo di pH e livello di bromo.
/ Allows monitoring of pH and bromine levels / Permet le contrôle du pH et du niveau de brome / Permite el control del pH y del nivel de bromo / Ermöglicht die Kontrolle des pH-Werts und des Bromgehalts.

Kit Mantenimento Spa / Spa Maintenance Kit / Kit d'entretien Spa / Kit de mantenimiento Spa / Spa-Pflegekit	40KITMAN	320
Kit Pulizia Spa / Spa Cleaning Kit / Kit de nettoyage Spa / Kit de limpieza Spa / Spa-Reinigungsset	40KITPUL	120

Poggiatesta-Sedute

/ Headrests – Seats / Appuie-tête – Assises / Reposacabezas – Asientos / Kopfstützen – Sitze



→ Soreha Mini Pool



→ Soreha Pool



→ Thea



→ Modula, Oniris



→ Marvelia, Aster, Miris

Solaris
Natura
Horizon

Albatros

08

Colonne da esterno

OUTDOOR COLUMNS



Solaris
pag. 92



Natura
pag. 94



Horizon
pag. 96

Solaris

DESIGN // ALBATROS R&D



 h 225 cm

**Finiture / Finishes /
Finitions / Acabados /
Oberflächen**



Cacao



Antracite

DOTAZIONI / FEATURES / ÉQUIPEMENTS / EQUIPAMIENTO / AUSSTATTUNG

Colonna doccia solare diametro / Solar shower column / Colonne de douche solaire / Columna de ducha solar / Solarduschsäule Ø 90 cm

Materiale acciaio inox 304 spessore 3mm / Stainless steel 304 material, 3 mm thickness / Matériau acier inox 304, épaisseur 3 mm / Material acero inoxidable 304, espesor 3 mm / Material Edelstahl 304, Stärke 3 mm ✓

Miscelatore progressivo / Progressive mixer / Mitigeur progressif / Mezclador progresivo / Progressiver Mischer ✓

Doccetta in acciaio inox / Stainless steel hand shower / Douchette en acier inox / Ducha de mano en acero inoxidable / Handbrause aus Edelstahl ✓

Capacità del serbatoio / Tank capacity / Capacité du réservoir / Capacidad del depósito / Tankkapazität 15 L

Attacco acqua / water connection / Raccord d'eau / Conexión de agua / Wasseranschluss 1/2"

Antracite

Cacao

SOLARIS

05SNA010

3.200

05SNC010

3.200

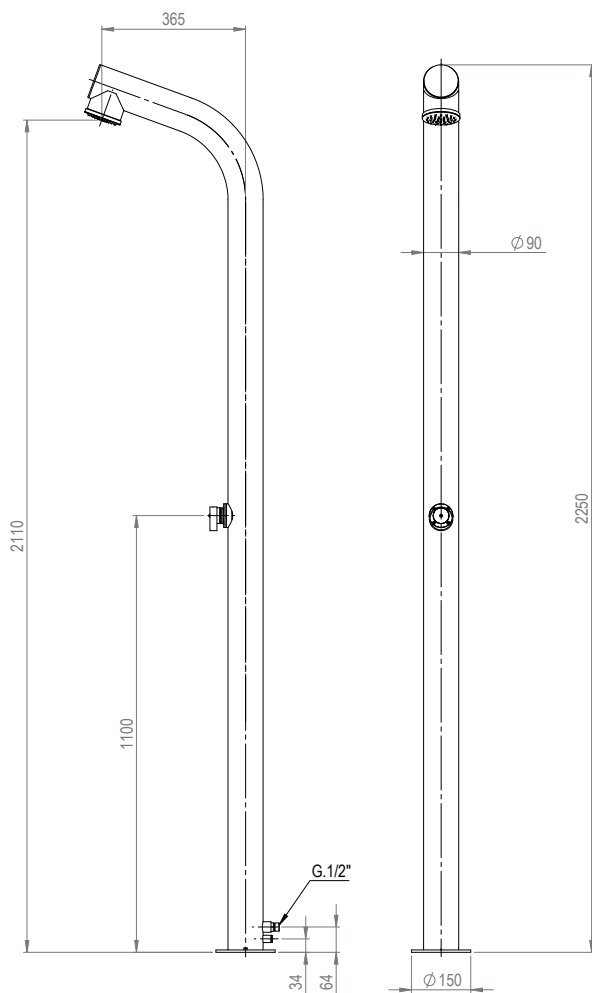

Natura

DESIGN // ALBATROS R&D



 h 225 cm

**Finiture / Finishes /
Finitions / Acabados /
Oberflächen**



**Acciaio inox satinato
/ Satin-finish stainless steel
/ Acier inox satiné
/ Acero inoxidable satinado
/ Satinierter Edelstahl**

DOTAZIONI / FEATURES / ÉQUIPEMENTS / EQUIPAMIENTO / AUSSTATTUNG

Tradizionale calda/fredda / Traditional hot/cold / Traditionnel chaud/froid / Tradicional caliente/fría / Traditionell warm/kalt ✓

Doccetta in acciaio inox / Doccetta in acciaio inox / Stainless steel hand shower / Douchette en acier inox / Ducha de mano en acero inoxidable / Handbrause aus Edelstahl ✓

Miscelatore progressivo ad alta precisione / High-precision progressive mixer / Mitigeur progressif haute précision / Mezclador progresivo de alta precisión / Hochpräziser progressiver Mischer ✓

Ugelli anti calcare / Anti-limescale nozzles / Buses anticalcaires / Boquillas antical / Antikalk-Düse ✓

Montaggio speedbox / Speedbox installation / Installation Speedbox / Montaje Speedbox / Speedbox-Montage ✓

Acciaio inox satinato / Satin-finish stainless steel
 Acier inox satiné / Acero inoxidable satinado
 Satinierter Edelstahl

NATURA

05PRVEN01

2.850

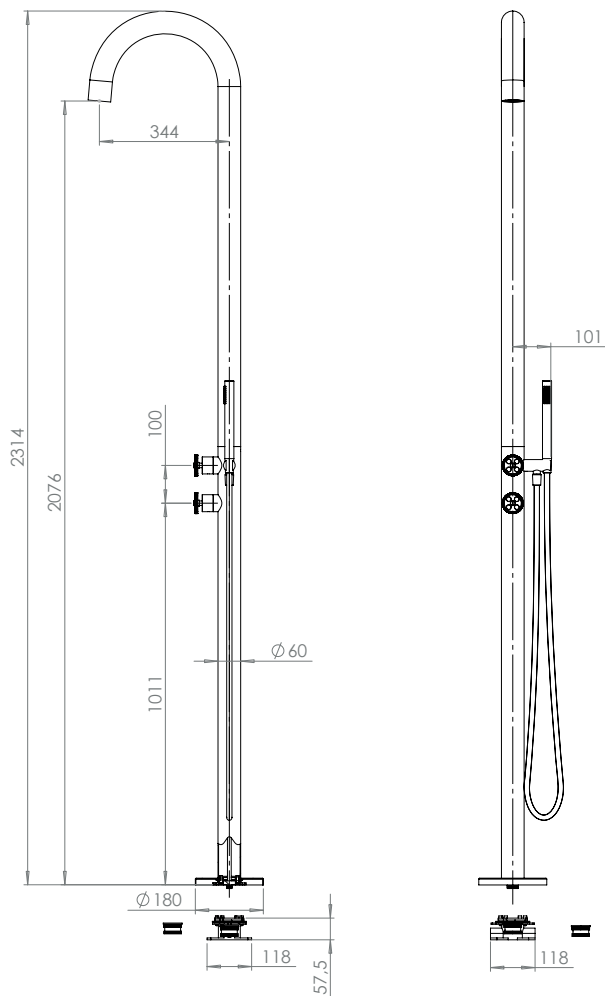

Horizon

DESIGN // ALBATROS R&D



 h 231,4 cm

**Finiture / Finishes /
Finitions / Acabados /
Oberflächen**



**Nero opaco
/ Matte black
/ Noir mat
/ Negro mate
/ Mattes Schwarz**

DOTAZIONI / FEATURES / ÉQUIPEMENTS / EQUIPAMIENTO / AUSSTATTUNG

Tradizionale calda/fredda / Traditional hot/cold / Traditionnel chaud/froid / Tradicional caliente/fría / Traditionell warm/kalt ✓

Miscelatore progressivo ad alta precisione / High-precision progressive mixer / Mitigeur progressif haute précision / Mezclador progresivo de alta precisión / Hochpräziser progressiver Mischer ✓

Ugelli anti calcare / Anti-limescale nozzles / Buses anticalcaires / Boquillas antica / Antikalk-Düsen ✓

Montaggio speedbox / Speedbox installation / Installation Speedbox / Montaje Speedbox / Speedbox-Montage ✓

Nero opaco / Matte black
Noir mat / Negro mate
Mattes Schwarz

HORIZON

05PRURA01

2.750

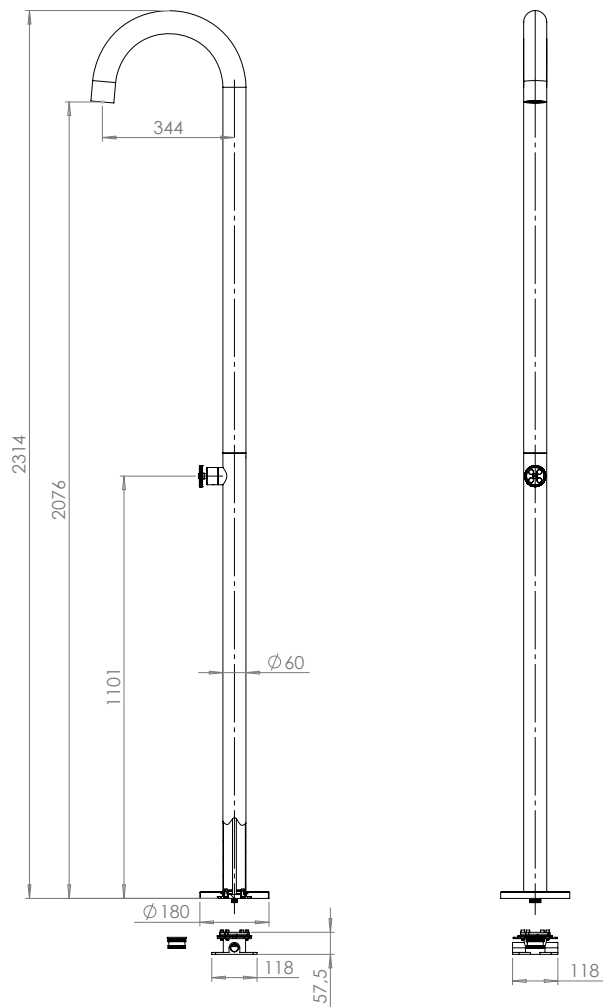

Syraka
Kellia
Tarim

Albatros

09

Vasche Secret System

BATHTUBS SYSTEM SPA



Syraka
pag. 100



Kellia
pag. 102



Tarim
pag. 104

Syraka Bath

DESIGN // ALBATROS R&D



 141 x 169 - h 55 cm

 280 lt | max

 180 kg

Finiture / Finishes / Finitions / Acabados / Oberflächen

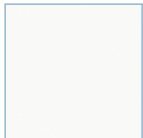

Solid Surface White



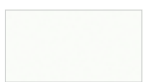







Pannelli Panels / Panneaux / Paneles / Panele Solid Surface



White



RAL

DOTAZIONI / FEATURES / ÉQUIPEMENTS / EQUIPAMIENTO / AUSSTATTUNG	BASE	EXCLUSIVE
 Whirlpool Jets	-	8
 Airpool Jets	-	24
 Bocchette Invisibili / Invisible nozzles / Buses invisibles / Boquillas invisibles / Unsichtbare Düsen	-	SecretJets
 Solid Surface	✓	✓
 Tappo in tinta / Color-matched drain / Bonde assortie à la couleur / Desagüe a juego / Farblich abgestimmter Ablauf	✓	✓
 Linfodrenaggio / Lymphatic drainage / Drainage lymphatique / Drenaje linfático / Lymphdrainage	✓	✓
 System Clean	-	✓
 Cromoterapia / Chromotherapy / Chromothérapie / Cromoterapia / Farbtherapie	-	✓
 Arredo Integrato Bianco Solid / White Solid Integrated furnishing / Mobilier Intégré blanc en surface solide / Mobiliario Integrado blanco / Integrierte Einrichtung in Weiß	✓	✓
 Display Touch	-	✓
 Pompe / Pumps / Pompes / Bombas / Pumpen	-	1 + 1 Blower

	BASE		EXCLUSIVE	
SYRAKA BATH TOTAL WHITE	01SY11BS	15.300	01SY1XBS	17.000
SYRAKA BATH RAL Colorazione solo esterna / External finish only / Coloration extérieure uniquement / Coloración solo externa / Farbgebung nur außen	01SY11**	22.800	01SY1X**	24.500

****Il codice verrà comunicato dopo la scelta del colore, previa fattibilità / The code will be provided after the color selection, subject to feasibility / Le code sera communiqué après le choix de la couleur, sous réserve de faisabilité / El código se comunicará después de la elección del color, previa viabilidad / Der Code wird nach der Farbauswahl, vorbehaltlich der Machbarkeit, mitgeteilt.**

Optional		Codice	
Riscaldatore 1,3 Kw / 1,3 Kw Heater / Réchauffeur 1,3 Kw / Calentador 1,3 Kw / Heizgerät 1,3 Kw		40RISC00	400
Rubinetteria con Cascata / Tapware with waterfall / Robinetterie avec cascade / Grifería con cascada / Armatur mit Wasserfall		Cromo Lucido / Polished chrome / Chrome poli / Cromo pulido / Polierter Chrom	40RUBCRO 538
		Acciaio Satinato Inox / Satin-finish stainless steel / Acier inox satiné / Acero inox satinado / Satinierter Edelstahl	40RUCISO 885

Dimensioni / Dimensions / Cotes
/ Cotas / Maße

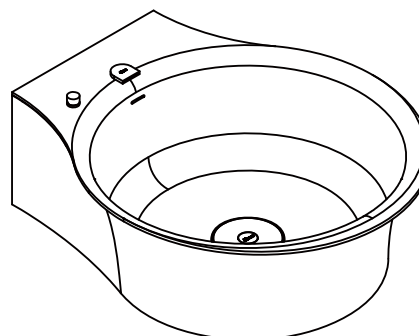
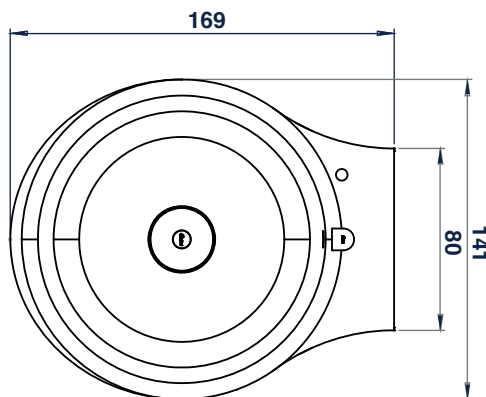

Kellia Bath

DESIGN // CLAUDIO PAPA



 **160 x 170 - h 55 cm**

 **280 lt | max**

 **250 kg**

Finiture / Finishes / Finitions / Acabados / Oberflächen



Solid Surface White











Pannelli Panels / Panneaux / Paneles / Paneele Solid Surface



White



RAL

DOTAZIONI / FEATURES / ÉQUIPEMENTS / EQUIPAMIENTO / AUSSTATTUNG	BASE	EXCLUSIVE
 Whirlpool Jets	-	8
 Airpool Jets	-	24
 Bocchette Invisibili / Invisible nozzles / Buses invisibles / Boquillas invisibles / Unsichtbare Düsen	-	SecretJets
 Solid Surface	✓	✓
 Tappo in tinta / Color-matched drain / Bonde assortie à la couleur / Desagüe a juego / Farblich abgestimmter Ablauf	✓	✓
 Linfodrenaggio / Lymphatic drainage / Drainage lymphatique / Drenaje linfático / Lymphdrainage	-	✓
 System Clean	-	✓
 Cromoterapia / Chromotherapy / Chromothérapie / Cromoterapia / Farbtherapie	-	✓
 Display Touch	-	✓
 Pompe / Pumps / Pompes / Bombas / Pumpen	-	1 + 1 Blower

		BASE		EXCLUSIVE		
KELLIA 0		White Solid	01KE11BS	8.800	01KEX1BS	16.400
KELLIA 1		White Solid	01KE1NBS	9.700	01KEXNBS	17.300
		Ral Solid	01KE1N**	10.400	01KEXN**	18.100
KELLIA 2		White Solid	01KE1ABS	10.600	01KEXABS	18.300
		Ral Solid	01KE1A**	12.200	01KEXA**	19.800
KELLIA 3		White Solid	01KE1PBS	11.500	01KEXPBS	19.200
		Ral Solid	01KE1P**	13.900	01KEXP**	21.500
KELLIA 4		White Solid	01KE1FBS	12.500	01KEXFBS	20.000
		Ral Solid	01KE1F**	15.500	01KEXF**	23.200

****Il codice verrà comunicato dopo la scelta del colore, previa fattibilità / The code will be provided after the color selection, subject to feasibility / Le code sera communiqué après le choix de la couleur, sous réserve de faisabilité / El código se comunicará después de la elección del color, previa viabilidad / Der Code wird nach der Farbauswahl, vorbehaltlich der Machbarkeit, mitgeteilt.**

Colorazione RAL solo esterna / External RAL finish only / Coloration RAL extérieure uniquement / Coloración RAL solo externa / Farbgebung RAL nur außen

Optional		Codice		
Riscaldatore 1,3 Kw / 1,3 Kw Heater / Réchauffeur 1,3 Kw / Calentador 1,3 Kw / Heizgerät 1,3 Kw		40RISC00	400	
Rubinetteria con Cascata / Tapware with waterfall / Robinetterie avec cascade / Grifería con cascada / Armatur mit Wasserfall		Cromo Lucido / Polished chrome / Chrome poli / Cromo pulido / Poliierter Chrom	40RUBCRO	538
		Acciaio Satinato Inox / Satin-finish stainless steel / Acier inox satiné / Acero inox satinado / Satinierter Edelstahl	40RUCISO	885

Quote / Dimensions / Cotes / Cotas / Maße

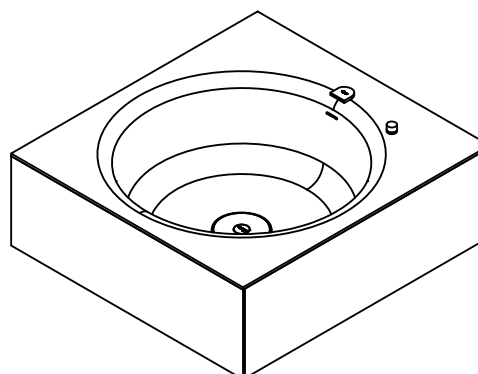
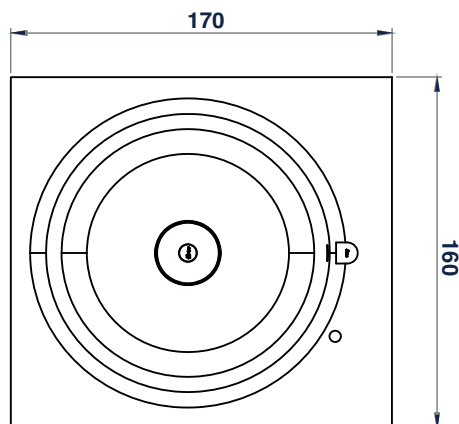

Tarim Bath

DESIGN // CLAUDIO PAPA



Versione D
/ Right-hand version
/ Version droite / Versión
derecha / Rechtsversion

 **202 x 84 - h 55 cm**

 **260 lt | max**

 **138 kg**

**Finiture / Finishes /
Finitions / Acabados /
Oberflächen**

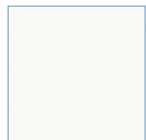

**Solid Surface
White**



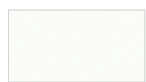







**Pannelli Panels /
Panneaux / Paneles /
Paneele Solid Surface**



White



RAL

DOTAZIONI / FEATURES / ÉQUIPEMENTS / EQUIPAMIENTO / AUSSTATTUNG	BASE	EXCLUSIVE
 Whirlpool Jets	-	12
 Airpool Jets	-	12
 Bocchette Invisibili / Invisible nozzles / Buses invisibles / Boquillas invisibles / Unsichtbare Düsen	-	SecretJets
 Solid Surface	✓	✓
 Tappo in tinta / Color-matched drain / Bonde assortie à la couleur / Desagüe a juego / Farblich abgestimmter Ablauf		
 Linfodrenaggio / Lymphatic drainage / Drainage lymphatique / Drenaje linfático / Lymphdrainage		
 System Clean	-	✓
 Cromoterapia / Chromotherapy / Chromothérapie / Cromoterapia / Farbtherapie	-	✓
 Arredo Integrato Bianco Solid / White Solid Integrated furnishing / Mobilier Intégré blanc en surface solide / Mobiliario Integrado blanco / Integrierte Einrichtung in Weiß	✓	✓
 Display Touch	-	✓
 Pompe / Pumps / Pompes / Bombas / Pumpen	-	1 + 1 Blower

			BASE		EXCLUSIVE	
TARIM 0		White Solid	01TANBBS	4.500	01TXNBBS	12.000
TARIM 1		White Solid	01TA*NBS	5.900	01TX*NBS	12.800
		Ral Solid	01TA*N**	6.500	01TX*N**	13.500
TARIM 2		White Solid	01TA*ABS	6.400	01TX*ABS	13.300
		Ral Solid	01TA*A**	7.000	01TX*A**	13.900
TARIM 3		White Solid	01TA*PBS	8.100	01TX*PBS	15.100
		Ral Solid	01TA*P**	9.800	01TX*P**	16.700
TARIM 4		White Solid	01TA*FBS	9.200	01TX*FBS	16.100
		Ral Solid	01TA*F**	11.500	01TX*F**	18.400

**Il codice verrà comunicato dopo la scelta del colore, previa fattibilità / The code will be provided after the color selection, subject to feasibility / Le code sera communiqué après le choix de la couleur, sous réserve de faisabilité / El código se comunicará después de la elección del color, previa viabilidad / Der Code wird nach der Farbauswahl, vorbehaltlich der Machbarkeit, mitgeteilt.

Colorazione RAL solo esterna / External RAL finish only / Coloration RAL extérieure uniquement / Coloración RAL solo externa / Farbgebung RAL nur außen

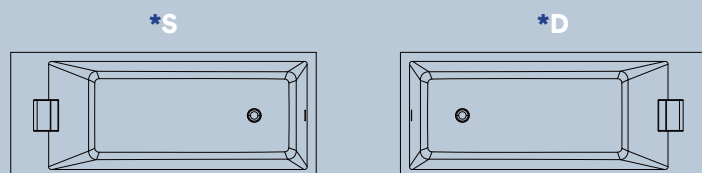

Optional	Codice	
Poggiatesta / Headrest / Appuie-tête / Reposacabezas / Kopfstütze	40TACS00	275
Riscaldatore 1,3 Kw / 1,3 Kw Heater / Réchauffeur 1,3 Kw / Calentador 1,3 Kw / Heizgerät 1,3 Kw	40RISC00	400

SECRET
SYSTEM BATH

Quote / Dimensions / Cotes
/ Cotas / Maße

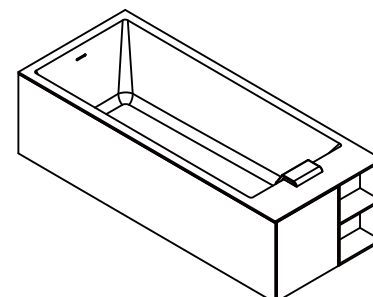
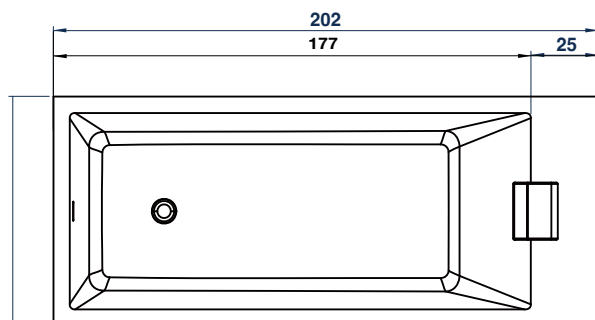

Soreha Mini Bath
Marvelia Bath
Aster Bath
Miris Bath

Albatros

10

Vasche Glamour

GLAMOUR BATHTUBS



Soreha Mini Bath
pag. 108



Marvelia Bath
pag. 110



Aster Bath
pag. 112



Miris Bath
pag. 114

Soreha Mini Bath

DESIGN // ALBATROS R&D

 **180 x 180 - h 57 cm**
 **480 lt | max**
 **128 kg**



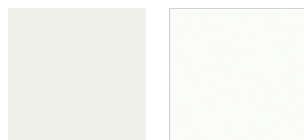



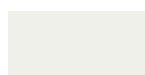
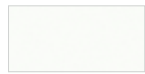





**Finiture / Finishes /
Finitions / Acabados /
Oberflächen**

**Molded
Glossy White****Molded Matt
White**

**Pannelli Panels /
Panneaux / Paneles /
Panele WOOD**

**Molded Matt
White****Molded Glossy
White****Elegant Tea For
Two (TT)****Tortona
Natural (TN)**

**DOTAZIONI / FEATURES / ÉQUIPEMENTS /
EQUIPAMIENTO / AUSSTATTUNG**

	BASE	EXCLUSIVE	TOP	ULTRA
 Whirlpool Jets	-	8	8	8
 Airpool Jets	-	-	14	14
 Bocchette / Nozzles / Buses / Boquillas / Düsen	-	SlimLine	SlimLine	SlimLine
 System Clean	-	✓	✓	✓
 Pannello Digitale / Digital Panel / Panneau numérique / Panel digital / Digitalpanel	-	✓	✓	✓
 Linfodrenaggio / Lymphatic drainage / Drainage lymphatique / Drenaje linfático / Lymphdrainage	-	✓	✓	✓
 Colonna di scarico con sifone / Drain column with siphon / Colonne d'évacuation avec siphon / Columna de desagüe con sifón / Ablaufsäule mit Siphon	✓	✓	✓	✓
 MicroSilk	Optional	-	-	-
 Tappo in tinta / Color-matched drain / Bonde assortie à la couleur / Desagüe a juego / Farblich abgestimmter Ablauf	✓	✓	✓	✓
 Pompe / Pumps / Pompes / Bombas / Pumpen	-	1	1 + 1 Blower	1 + 1 Blower
 Riscaldatore 1,3 Kw / 1,3 Kw Heater / Réchauffeur 1,3 Kw / Calentador 1,3 Kw / Heizgerät 1,3 Kw	-	-	-	✓
 Lampada RGB / RGB lamp / Lampe RGB / Lámpara RGB / RGB-Lampe	-	-	-	✓
 Materassino / Mat / Matelas / Colchoneta / Matte	✓	✓	✓	✓

		BASE		EXCLUSIVE		TOP		ULTRA		BASE + MICROSILK	
SOREHA MINI BATH	Glossy	01SO18BN	3.200	01SO19BN	5.400	01SO20BN	5.800	01SO22BN	6.700	01SO24MB	4.600
	Matt	01SO18ED	3.800	01SO19ED	6.000	01SO20ED	6.400	01SO22ED	7.300	01SO24ME	5.200

**Pannelli / Panels /
Panneaux / Paneles /
Paneele**



Molded Glossy White	40NFL4BN	2.100	40NFL3BN	1.600	40NFL2BN	1.100	40NFL1BN	600
Molded Matt White	40NFL4ED	1.400	40NFL3ED	1.100	40NFL2ED	800	40NFL1ED	400
Elegant Tea For Two (TT)	40NFL4TT	2.100	40NFL3TT	1.600	40NFL2TT	1.100	40NFL1TT	600
Graphite (GP)	40NFL4GP	2.100	40NFL3GP	1.600	40NFL2GP	1.100	40NFL1GP	600

Optional

Codice

Telecomando solo per versione Exclusive, Top e Ultra / Remote control only for Exclusive, Top and Ultra versions / Télécommande uniquement pour les versions Exclusive, Top et Ultra / Mando a distancia solo para las versiones Exclusive, Top y Ultra / Fernbedienung nur für die Versionen Exclusive, Top und Ultra		40TERC00	330
Colonna di scarico con erogazione / Drain column with dispensing / Colonne d'évacuation avec distribution / Columna de desagüe con dispensación / Ablaufsäule mit Auslass		40CER00	130
Rubinetteria D4 / Tapware / Robinetterie / Grifería / Armatur		40RD4CR0	1.200
		40RX4IS0	1.250
Rubinetteria D3 + Colonna di Scarico con erogazione / Tapware D3 + Drain column with dispensing / Robinetterie D3 + Colonne d'évacuation avec distribution / Grifería D3 + Columna de desagüe con dispensación / Armatur D3 + Ablaufsäule mit Auslass		40RD3CR0	1.100
		40RX3IS0	1.150

Aster Bath

DESIGN // ALBATROS R&D



 140 x 140 - h 60 cm

 340 lt | max



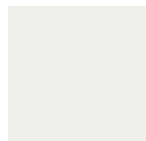

 150 kg

**Finiture / Finishes /
Finitions / Acabados /
Oberflächen**











Sprayed White

**Pannelli Panels /
Panneaux / Paneles /
Pannele WOOD**

	Sprayed White
	Elegant Tea For Two (TT)
	Tortona Natural (TN)
	Graphite (GP)
	Kashmir (KS)

DOTAZIONI / FEATURES / ÉQUIPEMENTS / EQUIPAMIENTO / AUSSTATTUNG

	BASE	EXCLUSIVE	TOP
 Whirlpool Jets	-	8	8
 Airpool Jets	-	-	12
 Bocchette / Nozzles / Buses / Boquillas / Düsen	-	SlimLine	SlimLine
 System Clean	-	✓	✓
 Pannello Digitale / Digital Panel / Panneau numérique / Panel digital / Digitalpanel	-	✓	✓
 Linfodrenaggio / Lymphatic drainage / Drainage lymphatique / Drenaje linfático / Lymphdrainage	-	✓	✓
 Colonna di scarico con sifone / Drain column with siphon / Colonne d'évacuation avec siphon / Column de desagüe con sifón / Abflusssäule mit Siphon	✓	✓	✓
 Tappo in tinta / Color-matched drain / Bonde assortie à la couleur / Desagüe a juego / Farblich abgestimmter Ablauf	✓	✓	✓
 Pompe / Pumps / Pompes / Bombas / Pump	-	1	1 + Blower

	BASE		EXCLUSIVE		TOP		
ASTER BATH	Glossy	01AS14BN	4.400	01AS16BN	6.400	01AS18BN	7.300

**Pannelli / Panels /
Panneaux / Paneles /
Pannele**

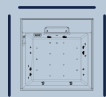

Molded Glossy White	40ASL4BN	1.900	40ASL3BN	1.400	40NFL2BN	1.000	40NFL1BN	600
Elegant Tea For Two (TT)	40ASL4TT	1.900	40ASL3TT	1.400	40NFL2TT	1.000	40NFL1TT	600
Graphite (GP)	40ASL4GP	1.900	40ASL3GP	1.400	40NFL2GP	1.000	40NFL1GP	600

Optional

Codice

Telecomando solo per versione Exclusive, Top e Ultra / Remote control only for Exclusive, Top and Ultra versions / Télécommande uniquement pour les versions Exclusive, Top et Ultra / Mando a distancia solo para las versiones Exclusive, Top y Ultra / Fernbedienung nur für die Versionen Exclusive, Top und Ultra	40TERC00	330
Colonna di scarico con erogazione / Drain column with dispensing / Colonne d'évacuation avec distribution / Columna de desagüe con dispensación / Ablaufsäule mit Auslass	40CER00	130
Rubinetteria D4 / Tapware / Robinetterie / Grifería / Armatur	Cromo Lucido / Polished chrome / Chrome poli / Cromo pulido / Polierter Chrom	40RD4CR0 1.200
	Acciaio Satinato Inox / Satin-finish stainless steel / Acier inox satiné / Acero inox satinado / Satinierter Edelstahl	40RX4IS0 1.250
Rubinetteria D3 + Colonna di Scarico con erogazione / Tapware D3 + Drain column with dispensing / Robinetterie D3 + Colonne d'évacuation avec distribution / Grifería D3 + Columna de desagüe con dispensación / Armatur D3 + Ablaufsäule mit Auslass	Cromo Lucido / Polished chrome / Chrome poli / Cromo pulido / Polierter Chrom	40RD3CR0 1.100
	Acciaio Satinato Inox / Satin-finish stainless steel / Acier inox satiné / Acero inox satinado / Satinierter Edelstahl	40RX3IS0 1.150



Marvelia Bath

DESIGN // ALBATROS R&D



 190 x 120 - h 61 cm

 340 lt | max

 120 kg

Finiture / Finishes / Finitions / Acabados / Oberflächen

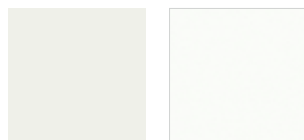

Molded Glossy White **Molded Matt White**

Pannelli Panels / Panneaux / Paneles / Panele WOOD

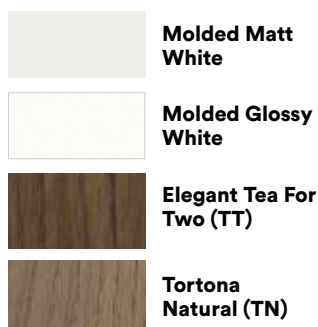













Molded Matt White

Molded Glossy White

Elegant Tea For Two (TT)

Tortona Natural (TN)

DOTAZIONI / FEATURES / ÉQUIPEMENTS / EQUIPAMIENTO / AUSSTATTUNG

	BASE	EXCLUSIVE	TOP	ULTRA
 Whirlpool Jets	-	12	12	12
 Airpool Jets	-	-	12	12
 Bocchette / Nozzles / Buses / Boquillas / Düsen	-	SlimLine	SlimLine	SlimLine
 System Clean	-	✓	✓	✓
 Pannello Digitale / Digital Panel / Panneau numérique / Panel digital / Digitalpanel	-	✓	✓	✓
 Linfodrenaggio / Lymphatic drainage / Drainage lymphatique / Drenaje linfático / Lymphdrainage	-	✓	✓	✓
 Colonna di scarico con sifone / Drain column with siphon / Colonne d'évacuation avec siphon / Columna de desagüe con sifón / Ablaufsäule mit Siphon	✓	✓	✓	✓
 MicroSilk	Optional	-	-	-
 Tappo in tinta / Color-matched drain / Bonde assortie à la couleur / Desagüe a juego / Farblich abgestimmter Ablauf	✓	✓	✓	✓
 Pompe / Pumps / Pompes / Bombas / Pumpen	-	1	1 + 1 Blower	1 + 1 Blower
 Riscaldatore 1,3 Kw / 1,3 Kw Heater / Réchauffeur 1,3 Kw / Calentador 1,3 Kw / Heizgerät 1,3 Kw	-	-	-	✓
 Lampada RGB / RGB lamp / Lampe RGB / Lámpara RGB / RGB-Lampe	-	-	-	✓

	BASE	EXCLUSIVE	TOP	ULTRA	BASE + MICROSILK
Glossy	01ED12BN 1.900	01ED16BN 4.200	01ED20BN 4.800	01ED22BN 5.600	01ED2MBN 3.500

MARVELIA BATH

Matt	01ED12EN 2.100	01ED16EN 4.400	01ED20EN 5.000	01ED22EN 5.800	01ED2MEN 3.700
------	----------------	----------------	----------------	----------------	----------------

**Pannelli / Panels /
Panneaux / Paneles /
Pannele**

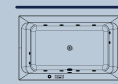
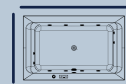
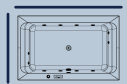
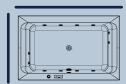

Molded Glossy White	40E22FBN 2.000	40EF2LBN 1.500	40EFL1BN 1.100	40EFL4BN 600
Molded Matt White	40E22FEW 1.400	40EF2LEW 1.100	40EFL1EW 800	40EFL4EW 450
Elegant Tea For Two (TT)	40E2FTT 2.000	40EF2LTT 1.500	40EFL1TT 1.100	40EFL4TT 600
Graphite (GP)	40E22FGP 2.000	40EF2LGP 1.500	40EFL1GP 1.100	40EFL4GP 600

Optional

Codice

Poggiatesta / Headrest / Appuie-tête / Reposacabezas / Kopfstütze	40EDCS00	250
Telecomand solo per versione Top e Ultra / Remote control only for Top and Ultra versions / Télécommande uniquement pour les versions Top et Ultra / Mando a distancia solo para las versiones Top y Ultra / Fernbedienung nur für die Versionen Top und Ultra	40TERC00	330
Colonna di scarico con erogazione / Drain column with dispensing / Colonne d'évacuation avec distribution / Column de desagüe con dispensación / Ablaufsäule mit Auslass	40CER00	130
Rubinetteria / Tapware / Robinetterie / Grifería / Armatur	Cromo Lucido / Polished chrome / Chrome poli / Cromo pulido / Polierter Chrom	40RD4CRO 1.200
	Acciaio Satinato Inox / Satin-finish stainless steel / Acier inox satiné / Acero inox satinado / Satinierter Edelstahl	40RX4ISO 1.250



Quote / Dimensions / Cotes / Cotas / Maße

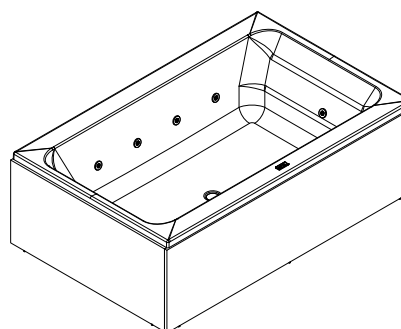
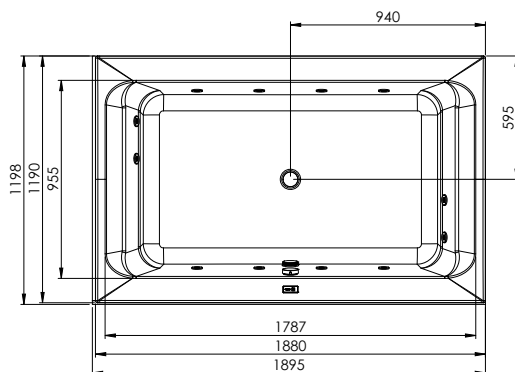

Miris Bath

DESIGN // ALBATROS R&D



Incassata / Built-in / Encastrable
/ Empartada / Einbau



 200 x 150 - h 61 cm

 480 lt | max

 128 kg

**Finiture / Finishes /
Finitions / Acabados /
Oberflächen**

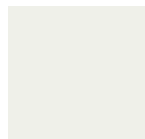

**Molded
Glossy White**

**Pannelli Panels /
Panneaux / Paneles /
Panele WOOD**

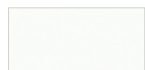

**Molded Glossy
White**















**Elegant Tea For
Two (TT)**



**Tortona
Natural (TN)**

DOTAZIONI / FEATURES / ÉQUIPEMENTS / EQUIPAMIENTO / AUSSTATTUNG

	BASE	EXCLUSIVE	TOP	ULTRA
 Whirlpool Jets	-	12	12	12
 Airpool Jets	-	-	12	12
 Bocchette / Nozzles / Buses / Boquillas / Düsen	-	FilJets	FilJets	FilJets
 System Clean	-	✓	✓	✓
 Pannello Digitale / Digital Panel / Panneau numérique / Panel digital / Digitalpanel	-	✓	✓	✓
 Linfodrenaggio / Lymphatic drainage / Drainage lymphatique / Drenaje linfático / Lymphdrainage	-	✓	✓	✓
 Colonna di scarico con sifone / Drain column with siphon / Colonne d'évacuation avec siphon / Columna de desagüe con sifón / Ablaufsäule mit Siphon	✓	✓	✓	✓
 MicroSilk	Optional	-	-	-
 Tappo in tinta / Color-matched drain / Bonde assortie à la couleur / Desagüe a juego / Farblich abgestimmter Ablauf	✓	✓	✓	✓
 Pompe / Pumps / Pompes / Bombas / Pumpen	-	1	1 + 1 Blower	1 + 1 Blower
 Riscaldatore 1,3 Kw / 1,3 Kw Heater / Réchauffeur 1,3 Kw / Calentador 1,3 Kw / Heizgerät 1,3 Kw	-	-	-	✓
 Lampada RGB / RGB lamp / Lampe RGB / Lámpara RGB / RGB-Lampe	-	-	-	✓

	BASE	EXCLUSIVE	TOP	ULTRA	BASE + MICROSILK
MIRIS BATH	Glossy 01MI20BN 3.200	01MI22BN 5.500	01MI24BN 6.100	01MI26BN 6.900	01MI2MBN 4.800

**Pannelli / Panels /
Panneaux / Paneles /
Paneele**

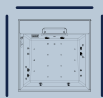
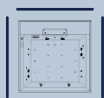

Molded Glossy White	40MIL4BN	2.100	40MIL3BN	1.600	40MIL2BN	1.100	40MIL1BN	600
Elegant Tea For Two (TT)	40MIL4TT	2.100	40MIL3TT	1.600	40MIL2TT	1.100	40MIL1TT	600
Graphite (GP)	40MIL4GP	2.100	40MIL3GP	1.600	40MIL2GP	1.100	40MIL1GP	600

Optional

Codice

Poggiatesta / Headrest / Appuie-tête / Reposacabezas / Kopfstütze **40MICS00** **250**

Telecomando solo per versione Exclusive, Top e Ultra / Remote control only for Exclusive, Top and Ultra versions / Télécommande uniquement pour les versions Exclusive, Top et Ultra / Mando a distancia solo para las versiones Exclusive, Top y Ultra / Fernbedienung nur für die Versionen Exclusive, Top und Ultra **40TERC00** **330**

Colonna di scarico con erogazione / Drain column with dispensing / Colonne d'évacuation avec distribution / Column de desagüe con dispensación / Ablaufsäule mit Auslass **40CER00** **130**

Rubinetteria D4 / Tapware / Robinetterie / Grifería / Armatur



Cromo Lucido / Polished chrome / Chrome poli / Cromo pulido / Polierter Chrom **40RD4CR0** **1.200**

Acciaio Satinato Inox / Satin-finish stainless steel / Acier inox satiné / Acero inox satinado / Satinierter Edelstahl **40RX4IS0** **1.250**

Rubinetteria D3 + Colonna di Scarico con erogazione / Tapware D3 + Drain column with dispensing / Robinetterie D3 + Colonne d'évacuation avec distribution / Grifería D3 + Column de desagüe con dispensación / Armatur D3 + Ablaufsäule mit Auslass



Cromo Lucido / Polished chrome / Chrome poli / Cromo pulido / Polierter Chrom **40RD3CR0** **1.100**

Acciaio Satinato Inox / Satin-finish stainless steel / Acier inox satiné / Acero inox satinado / Satinierter Edelstahl **40RX3IS0** **1.150**

Talima Bathtubs

Talima Freestanding
Talima Panel
Talima Wall

Albatros

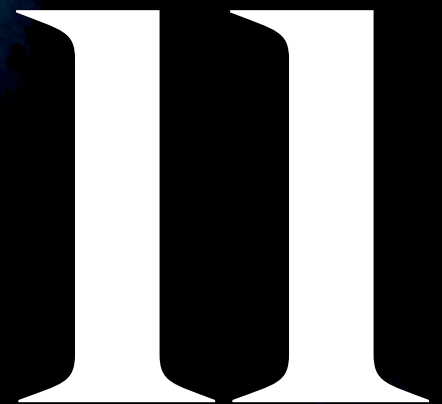

Vasche Talima

TALIMA BATHTUBS



Talima Freestanding
pag. 118



Talima Panel
pag. 120



Talima Wall
pag. 122

Talima Freestanding

DESIGN // ALBATROS R&D



 **170 x 70 - h 50 cm**

 **278 lt | max**

 **126 kg**

DOTAZIONI / FEATURES / ÉQUIPEMENTS / EQUIPAMIENTO / AUSSTATTUNG

PLUS



Solid Surface



Piletta Sifonata / Siphon Drain / Bonde siphonnée / Desagüe sifonado / Siphonablauf



Finiture / Finishes / Finitions / Acabados / Oberflächen

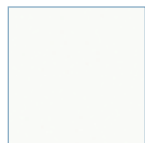

**Solid Surface
White**



**Solid Surface
RAL**

**Quote / Dimensions / Cotes
/ Cotas / Maße**

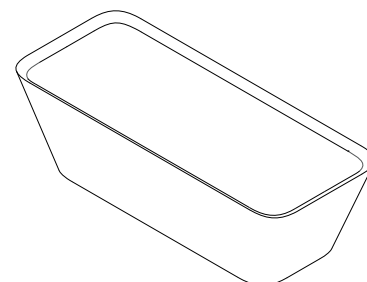
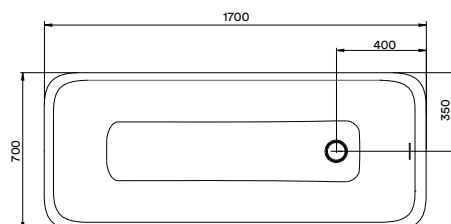

PLUS

TALIMA FREESTANDING

Solid Surface White	01SO1FBN	4.950
Solid Surface RAL	01SO2F**	6.700
Solid Surface White & RAL BiColor	01SO1F**	6.200

**Il codice verrà comunicato dopo la scelta del colore, previa fattibilità / The code will be provided after the color selection, subject to feasibility / Le code sera communiqué après le choix de la couleur, sous réserve de faisabilité / El código se comunicará después de la elección del color, previa viabilidad / Der Code wird nach der Farbauswahl, vorbehaltlich der Machbarkeit, mitgeteilt.



TALIMA
BATH

Talima Panel

DESIGN // ALBATROS R&D







Versione D
Right-hand version / Version droite
/ Versión derecha / Rechtsversion

 180 ~ 220 cm

 80 ~ 120 | H 50 cm

 245 lt

DOTAZIONI / FEATURES / ÉQUIPEMENTS / EQUIPAMIENTO / AUSSTATTUNG	BASE	EXCLUSIVE
 Solid Surface	✓	✓
 Piletta Sifonata / Siphon Drain / Bonde siphonnée / Desagüe sifonado / Siphonablauf	✓	✓
 Misure personalizzate / Custom dimensions / Dimensions personnalisées / Medidas personalizadas / Maßgeschneiderte Abmessungen	✓	✓
 Airpool Jets	-	12
 Telecomando per Airpool / Remote control for Airpool / Télécommande pour Airpool / Mando a distancia para Airpool / Fernbedienung für Airpool	-	✓

Finiture / Finishes / Finitions / Acabados / Oberflächen



Solid Surface White

Solid Surface RAL

Pannelli Panels / Panneaux / Paneles / Panele

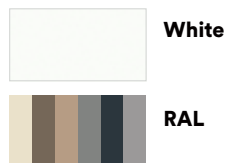

White

RAL

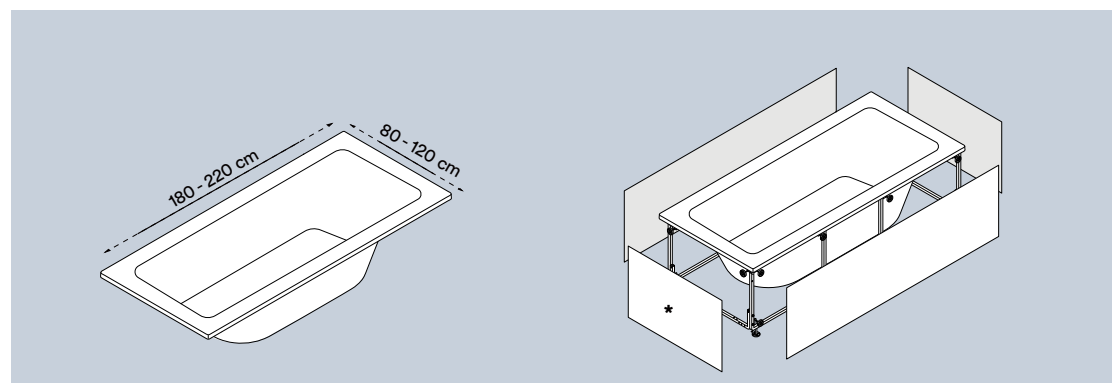

* Il telaio è disponibile solo per Airpool / The frame is only available for Airpool / Le châssis est disponible uniquement pour Airpool / El bastidor está disponible solo para Airpool / Der Rahmen ist nur für Airpool erhältlich

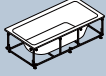
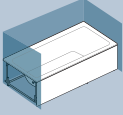
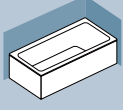
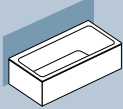
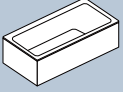
			BASE		EXCLUSIVE	
TALIMA PANEL 0		White	01SP01BN	5.800	01SP06BN	8.700
TALIMA PANEL 1		White	01SP21BN	6.200	01SPN6B*	9.900
		BiColor White + RAL	01SP21B**N	6.400	01SP6B**N*	10.100
TALIMA PANEL 2		White	01SP21BA	6.500	01SPA6B*	10.500
		BiColor White + RAL	01SP21B**A	7.100	01SP6B**A*	11.900
TALIMA PANEL 3		White	01SP21BP	7.000	01SPP6BN	11.200
		BiColor White + RAL	01SP21B**P	7.900	01SP6B**P	12.100
TALIMA PANEL 4		White	01SP21BC	7.700	01SPC6BN	12.300
		BiColor White + RAL	01SP21B**C	9.300	01SP6B**C	13.900

**Il codice verrà comunicato dopo la scelta del colore, previa fattibilità / The code will be provided after the color selection, subject to feasibility / Le code sera communiqué après le choix de la couleur, sous réserve de faisabilité / El código se comunicará después de la elección del color, previa viabilidad / Der Code wird nach der Farbauswahl, vorbehaltlich der Machbarkeit, mitgeteilt.

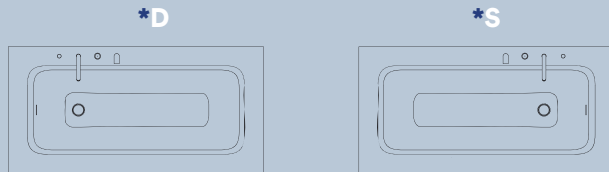

Optional		Codice	
Rubinetteria / Tapware / Robinetterie / Grifería / Armatur		Cromo Lucido / Polished chrome / Chrome poli / Cromo pulido / Poliierter Chrom	40RD4CRO 1.200
		Acciaio Satinato Inox / Satin-finish stainless steel / Acier inox satiné / Acero inox satinado / Satinierter Edelstahl	40RX4ISO 1.250

Quote / Dimensions / Cotes / Cotas / Maße

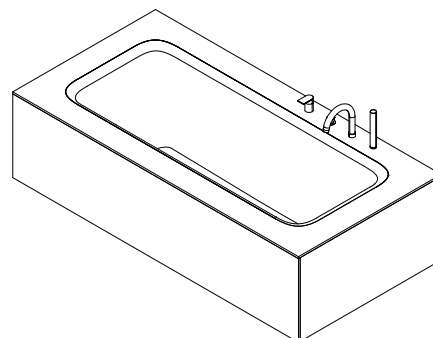
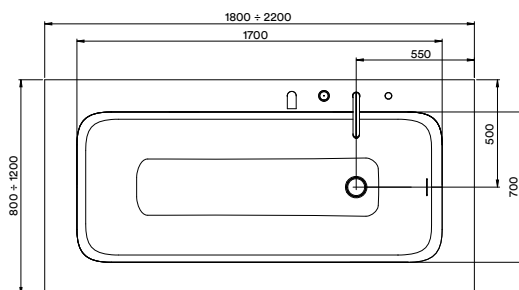

Talima Wall

DESIGN // CLAUDIO PAPA







Versione S
Left-hand version / Version gauche
/ Versión izquierda / Linke Ausführung

 **196 x 88 - h 50 cm**

 **278 lt | max**

 **125 kg**

DOTAZIONI / FEATURES / ÉQUIPEMENTS / EQUIPAMIENTO / AUSSTATTUNG	BASE	EXCLUSIVE
 Solid Surface	✓	✓
 Piletta Sifonata e tappo in tinta / Siphon Drain and Color-matched drain/ Bonde siphonnée et Bonde assortie à la couleur / Desagüe sifonado y Desagüe a juego / Siphonablauf und Farblich abgestimmter Ablauf	✓	✓
 Airpool Jets	-	12
 Telecomando per Airpool / Remote control for Airpool / Télécommande pour Airpool / Mando a distancia para Airpool / Fernbedienung für Airpool	-	✓

Finiture / Finishes / Finitions / Acabados / Oberflächen



Solid Surface White

Solid Surface RAL

Quote / Dimensions / Cotes / Cotas / Maße

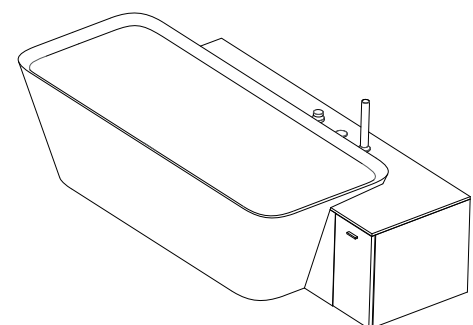
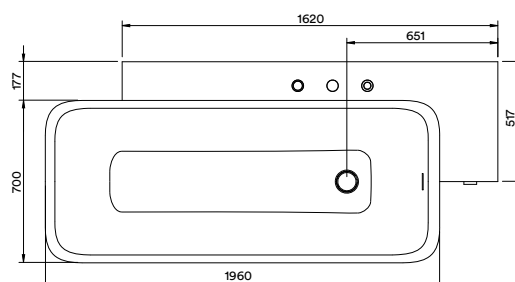

//Versione DX/RH version
Per la versione SX, la disposizione è speculare
For the LH version, reverse the drawing

TALIMA WALL

TALIMA WALL FREESTANDING

Con pannello perimetrale per installazione centro stanza / With perimeter panel for freestanding installation / Avec panneau périmétral pour installation en îlot / Con panel perimetral para instalación exenta / Mit Umfangspanel für freistehende Installation

	BASE		EXCLUSIVE	
White	01SWN1B*	7.000	01SWN6B*	10.400
RAL	01SWN1***	9.100	-	-
White	01SWC1B*	7.600	01SWC6B*	11.200
RAL	01SWC1***	9.900	-	-

**Il codice verrà comunicato dopo la scelta del colore, previa fattibilità / The code will be provided after the color selection, subject to feasibility / Le code sera communiqué après le choix de la couleur, sous réserve de faisabilité / El código se comunicará después de la elección del color, previa viabilidad / Der Code wird nach der Farbauswahl, vorbehaltlich der Machbarkeit, mitgeteilt.



Optional

Codice

Rubinetteria / Tapware / Robinetterie / Grifería / Armatur



Cromo Lucido / Polished chrome / Chrome poli / Cromo pulido / Polierter Chrom

40RD4CRO 1.200

Acciaio Satinato Inox / Satin-finish stainless steel / Acier inox satiné / Acero inox satinado / Satinierter Edelstahl

40RX4ISO 1.250



Ethos Freestanding Color
Ethos Freestanding Plus
Ethos Panel
Ethos Wall
Ethos 90° 140
Ethos Round 180

Albatros

12

Vasche Ethos

ETHOS BATHTUBS



Ethos Color
pag. 126



Ethos Plus
pag. 128



Ethos Panel
pag. 130



Ethos Wall
pag. 132



Ethos 90° 140
pag. 134



Ethos Round 180
pag. 136

Ethos Freestanding Color

DESIGN // ALBATROS R&D



 170 x 70 - h 50 cm

 264 lt | max

 102 kg

DOTAZIONI / FEATURES / ÉQUIPEMENTS / EQUIPAMIENTO / AUSSTATTUNG

PLUS



Solid Surface

✓



Piletta Sifonata e tappo in tinta / Siphon Drain and Color-matched drain/ Bonde siphonnée et Bonde assortie à la couleur / Desagüe sifonado y Desagüe a juego / Siphonablauf und Farblich abgestimmter Ablauf

✓

Finiture / Finishes / Finitions / Acabados / Oberflächen

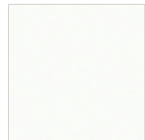

Solid Surface
White



Solid Surface
RAL

Quote / Dimensions / Cotes / Cotas / Maße

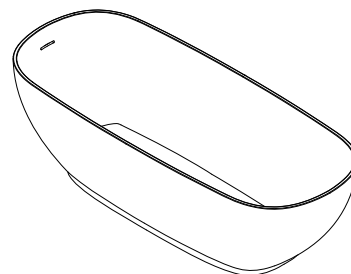
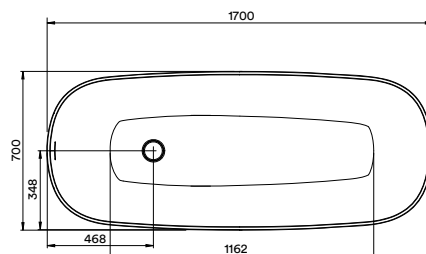

PLUS

ETHOS FREESTANDING COLOR

Solid Surface White	01ET1FBN	4.800
Solid Surface RAL	01ET2F**	6.200
Solid Surface White & RAL BiColor	01ET1F**	5.800

**Il codice verrà comunicato dopo la scelta del colore, previa fattibilità / The code will be provided after the color selection, subject to feasibility / Le code sera communiqué après le choix de la couleur, sous réserve de faisabilité / El código se comunicará después de la elección del color, previa viabilidad / Der Code wird nach der Farbauswahl, vorbehaltlich der Machbarkeit, mitgeteilt.



Ethos Freestanding Plus



 160 x 70 - h 61 cm
170 x 75 - h 61 cm
180 x 80 - h 61 cm

 160 x 70: 240 lt
170 x 75: 270 lt
180 x 80: 310 lt

 160 x 70: 113 kg
170 x 75: 127 kg
180 x 80: 142 kg

Finiture / Finishes / Finitions / Acabados / Oberflächen

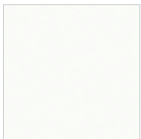

**Solid Surface
White**

DOTAZIONI / FEATURES / ÉQUIPEMENTS / EQUIPAMIENTO / AUSSTATTUNG

PLUS



Solid Surface

✓



Piletta Sifonata e tappo in tinta / Siphon Drain and Color-matched drain/ Bonde siphonnée et Bonde assortie à la couleur / Desagüe sifonado y Desagüe a juego / Siphonablauf und Farblich abgestimmter Ablauf

✓

Quote / Dimensions / Cotes / Cotas / Maße

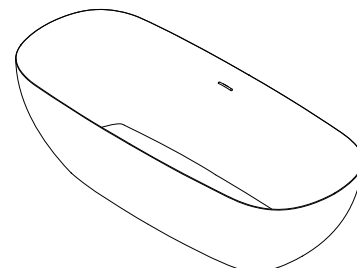
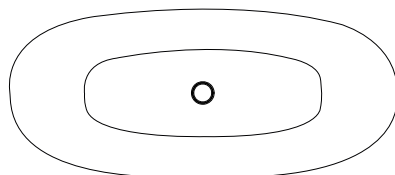

ETHOS FREESTANDING PLUS 160 X 70

WHITE SOLID

01ER3FBN 3.700

ETHOS FREESTANDING PLUS 170 X 75

01ER4FBN 4.700

ETHOS FREESTANDING PLUS 180 X 80

01ER5FBN 5.100



Ethos Panel

DESIGN // ALBATROS R&D







Versione D
Right-hand version / Version droite
/ Versión derecha / Rechtsversion

 180 ~ 220 cm

 80 ~ 120 | H 50 cm

 259 lt

DOTAZIONI / FEATURES / ÉQUIPEMENTS / EQUIPAMIENTO / AUSSTATTUNG	BASE	EXCLUSIVE
 Solid Surface	✓	✓
 Piletta Sifonata e tappo in tinta / Siphon Drain and Color-matched drain/ Bonde siphonnée et Bonde assortie à la couleur / Desagüe sifonado y Desagüe a juego / Siphonablauf und Farblich abgestimmter Ablauf	✓	✓
 Misure personalizzate / Custom dimensions / Dimensions personnalisées / Medidas personalizadas / Maßgeschneiderte Abmessungen	✓	✓
 Airpool Jets	-	✓
 Telecomando per Airpool / Remote control for Airpool / Télécommande pour Airpool / Mando a distancia para Airpool / Fernbedienung für Airpool	-	✓

Finiture / Finishes / Finitions / Acabados / Oberflächen



Solid Surface White

Solid Surface RAL

Pannelli Panels / Panneaux / Paneles / Panele

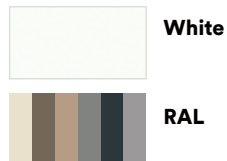

White

RAL

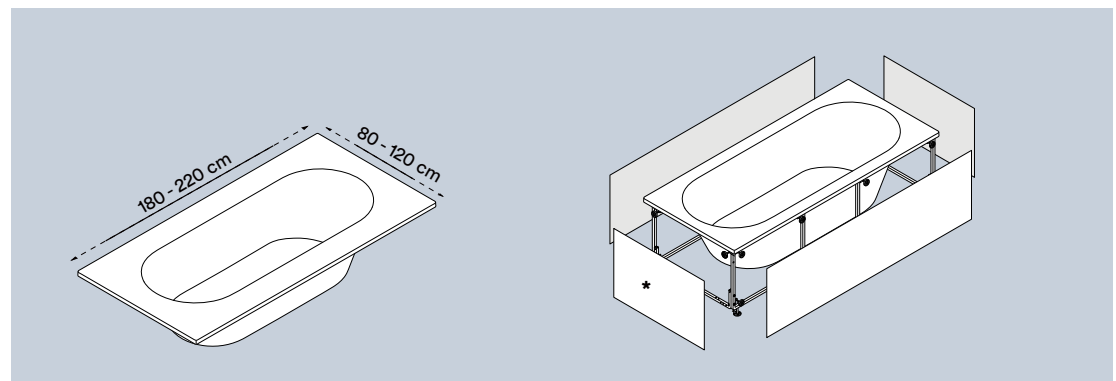

* Il telaio è disponibile solo per Airpool / The frame is only available for Airpool / Le châssis est disponible uniquement pour Airpool / El bastidor está disponible solo para Airpool / Der Rahmen ist nur für Airpool erhältlich

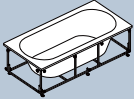
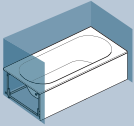
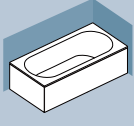
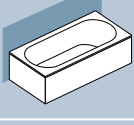
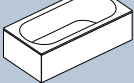
			BASE		EXCLUSIVE	
ETHOS PANEL 0		White	01EP01BN	5.800	01EP06BN	8.500
ETHOS PANEL 1		White	01EP21BN	6.200	01EPN6B*	9.600
		BiColor White + RAL	01EP21B**N	6.400	01EP6B**N*	9.800
ETHOS PANEL 2		White	01EP21BA	6.500	01EPA6B*	10.300
		BiColor White + RAL	01EP21B**A	7.000	01EP6B**A*	10.800
ETHOS PANEL 3		White	01EP21BP	7.000	01EPP6BN	10.900
		BiColor White + RAL	01EP21B**P	7.500	01EP6B**P	11.400
ETHOS PANEL 4		White	01EP21BC	7.700	01EPC6BN	12.000
		BiColor White + RAL	01EP21B**C	9.200	01EP6B**C	12.500

**Il codice verrà comunicato dopo la scelta del colore, previa fattibilità / The code will be provided after the color selection, subject to feasibility / Le code sera communiqué après le choix de la couleur, sous réserve de faisabilité / El código se comunicará después de la elección del color, previa viabilidad / Der Code wird nach der Farbauswahl, vorbehaltlich der Machbarkeit, mitgeteilt.

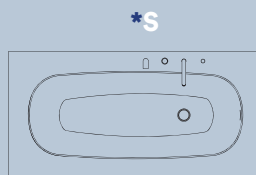
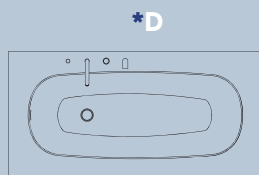

Optional

Codice

Rubinetteria / Tapware / Robinetterie / Grifería / Armatur



Cromo Lucido / Polished chrome / Chrome poli / Cromo pulido / Polierter Chrom

40RD4CRO

1.200

Acciaio Satinato Inox / Satin-finish stainless steel / Acier inox satiné / Acero inox satinado / Satinierter Edelstahl

40RX4ISO

1.250

Quote / Dimensions / Cotes / Cotas / Maße

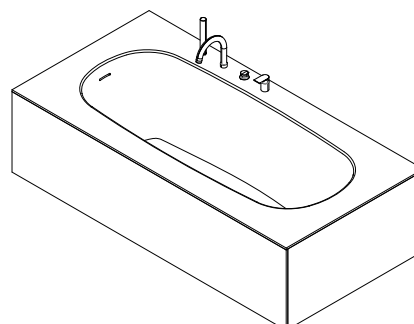
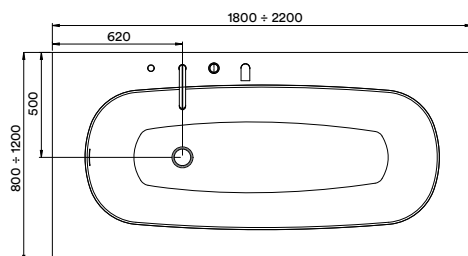

Ethos Wall

DESIGN // CLAUDIO PAPA







Versione S
Left-hand version / Version gauche
/ Versión izquierda / Linke Ausführung

 **196 x 87 - h 50 cm**

 **259 lt | max**

 **122 kg**

DOTAZIONI / FEATURES / ÉQUIPEMENTS / EQUIPAMIENTO / AUSSTATTUNG	BASE	EXCLUSIVE
 Solid Surface	✓	✓
 Piletta Sifonata e tappo in tinta / Siphon Drain and Color-matched drain/ Bonde siphonnée et Bonde assortie à la couleur / Desagüe sifonado y Desagüe a juego / Siphonablauf und Farblich abgestimmter Ablauf	✓	✓
 Airpool Jets	-	✓
 Telecomando per Airpool / Remote control for Airpool / Télécommande pour Airpool / Mando a distancia para Airpool / Fernbedienung für Airpool	-	✓

Finiture / Finishes / Finitions / Acabados / Oberflächen

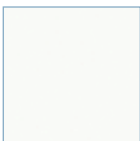

Solid Surface White



Solid Surface RAL

Quote / Dimensions / Cotes / Cotas / Maße

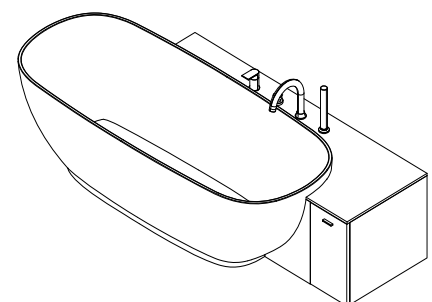
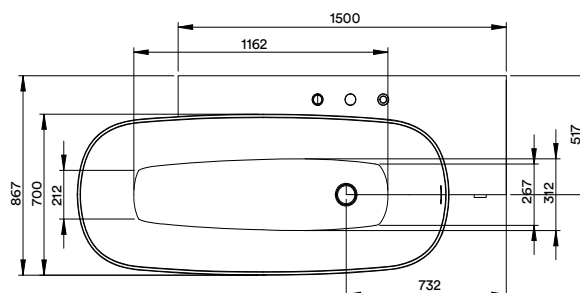

ETHOS WALL

ETHOS WALL FREESTANDING

Con pannello perimetrale per installazione centro stanza / With perimeter panel for freestanding installation / Avec panneau périmétral pour installation en îlot / Con panel perimetral para instalación exenta / Mit Umfangspanel für freistehende Installation

	BASE		EXCLUSIVE	
White	01EWN1B*	6.800	01EWN6B*	9.700
RAL	01EWN1***	8.600	-	-
White	01EWC1B*	7.400	01EWC6B*	10.400
RAL	01EWC1***	9.400	-	-

**Il codice verrà comunicato dopo la scelta del colore, previa fattibilità / The code will be provided after the color selection, subject to feasibility / Le code sera communiqué après le choix de la couleur, sous réserve de faisabilité / El código se comunicará después de la elección del color, previa viabilidad / Der Code wird nach der Farbauswahl, vorbehaltlich der Machbarkeit, mitgeteilt.

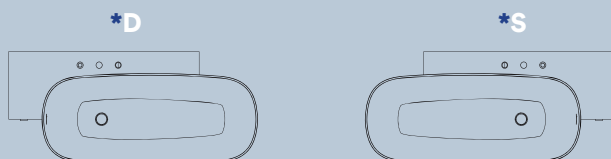

Optional

Codice

Rubinetteria / Tapware / Robinetterie / Grifería / Armatur



Cromo Lucido / Polished chrome / Chrome poli / Cromo pulido / Polierter Chrom

40RD4CRO

1.200

Acciaio Satinato Inox / Satin-finish stainless steel / Acier inox satiné / Acero inox satinado / Satinierter Edelstahl

40RX4ISO

1.250



Ethos 90° 140

DESIGN // ALBATROS R&D



140 x 140 - h 57 cm

260 lt | max

82 kg

**Finiture / Finishes /
Finitions / Acabados /
Oberflächen**

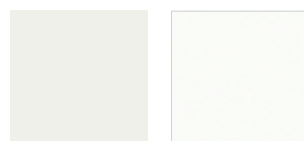

**Molded
Glossy White**

**Molded Matt
White**

**Pannelli Panels /
Panneaux / Paneles /
Panele WOOD**

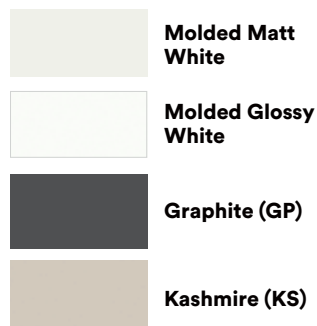

**Molded Matt
White**

**Molded Glossy
White**

Graphite (GP)

Kashmire (KS)

**DOTAZIONI / FEATURES / ÉQUIPEMENTS /
EQUIPAMIENTO / AUSSTATTUNG**

	BASE	EXCLUSIVE	TOP	ULTRA
Whirlpool Jets	-	6	6	6
Airpool Jets	-	-	14	14
Bocchette / Nozzles / Buses / Boquillas / Düsen	-	FilJets	FilJets	FilJets
System Clean	-	✓	✓	✓
Pannello Digitale / Digital Panel / Panneau numérique / Panel digital / Digitalpanel	-	✓	✓	✓
Linfodrenaggio / Lymphatic drainage / Drainage lymphatique / Drenaje linfático / Lymphdrainage	-	✓	✓	✓
Colonna di scarico con sifone / Drain column with siphon / Colonne d'évacuation avec siphon / Columna de desagüe con sifón / Ablaufsäule mit Siphon	✓	✓	✓	✓
MicroSilk	Optional	-	-	-
Tappo in tinta / Color-matched drain / Bonde assortie à la couleur / Desagüe a juego / Farblich abgestimmter Ablauf	✓	✓	✓	✓
Pompe / Pumps / Pompes / Bombas / Pumpen	-	1	1 + 1 Blower	1 + 1 Blower
Riscaldatore 1,3 Kw / 1,3 Kw Heater / Réchauffeur 1,3 Kw / Calentador 1,3 Kw / Heizgerät 1,3 Kw	-	-	-	✓
Lampada RGB / RGB lamp / Lampe RGB / Lámpara RGB / RGB-Lampe	-	-	-	✓

	BASE	EXCLUSIVE	TOP	ULTRA	BASE + MICROSILK
	Glossy 01ET22BS 1.700	01ET24BS 4.400	01ET25BS 4.800	01ET26BS 5.100	01ET2MBS 3.600

ETHOS 140

	Matt 01ET22ES 1.950	01ET24ES 4.650	01ET25ES 5.050	01ET26BS 5.350	01ET2MES 3.850
--	---------------------	----------------	----------------	----------------	----------------

Pannelli / Panels / Panneaux / Paneles / Paneele

	GLOSSY	MATT	KS	GP
ETHOS 140 Pannello Angolare 140 / Corner Panel 140 / Panneau d'angle 140 / Panel de esquina 140 / Eckpaneel 140	40E140BN 650	40E140EW 720	40E140KS 1.200	40E140GP 1.200

Optional

Codice

Telecomando solo per versione Exclusive, Top e Ultra / Remote control only for Exclusive, Top and Ultra versions / Télécommande uniquement pour les versions Exclusive, Top et Ultra / Mando a distancia solo para las versiones Exclusive, Top y Ultra / Fernbedienung nur für die Versionen Exclusive, Top und Ultra		40TERC00	330
Colonna di scarico con erogazione / Drain column with dispensing / Colonne d'évacuation avec distribution / Column de desagüe con dispensación / Ablaufsäule mit Auslass		40CER00	130
Rubinetteria D4 / Tapware / Robinetterie / Grifería / Armatur		Cromo Lucido / Polished chrome / Chrome poli / Cromo pulido / Polierter Chrom	40RD4CRO 1.200
		Acciaio Satinato Inox / Satin-finish stainless steel / Acier inox satiné / Acero inox satinado / Satinierter Edelstahl	40RX4ISO 1.250
Rubinetteria D3 + Colonna di Scarico con erogazione / Tapware D3 + Drain column with dispensing / Robinetterie D3 + Colonne d'évacuation avec distribution / Grifería D3 + Columna de desagüe con dispensación / Armatur D3 + Ablaufsäule mit Auslass		Cromo Lucido / Polished chrome / Chrome poli / Cromo pulido / Polierter Chrom	40RD3CRO 1.100
		Acciaio Satinato Inox / Satin-finish stainless steel / Acier inox satiné / Acero inox satinado / Satinierter Edelstahl	40RX3ISO 1.150

Quote / Dimensions / Cotes / Cotas / Maße

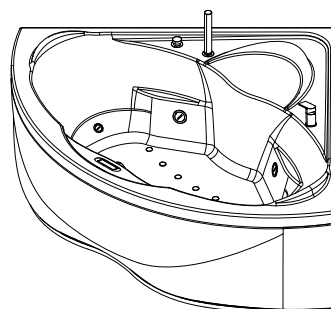
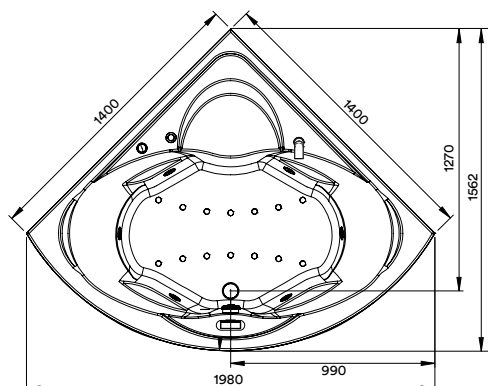

Ethos Round 180

DESIGN // ALBATROS R&D



Ø 180 - h 64 cm

486 lt | max

93 kg

Finiture / Finishes / Finitions / Acabados / Oberflächen

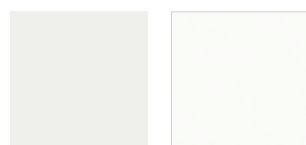

Molded Glossy White **Molded Matt White**

Pannelli Panels / Panneaux / Paneles / Paneele

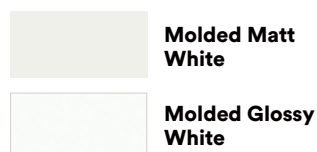

Molded Matt White

Molded Glossy White

DOTAZIONI / FEATURES / ÉQUIPEMENTS / EQUIPAMIENTO / AUSSTATTUNG



	BASE	EXCLUSIVE	TOP	ULTRA
Whirlpool Jets	-	8	8	8
Airpool Jets	-	-	14	14
Bocchette / Nozzles / Buses / Boquillas / Düsen	-	FilJets	FilJets	FilJets
System Clean	-	✓	✓	✓
Pannello Digitale / Digital Panel / Panneau numérique / Panel digital / Digitalpanel	-	✓	✓	✓
Linfodrenaggio / Lymphatic drainage / Drainage lymphatique / Drenaje linfático / Lymphdrainage	-	✓	✓	✓
Colonna di scarico con sifone / Drain column with siphon / Colonne d'évacuation avec siphon / Columna de desagüe con sifón / Ablaufsäule mit Siphon	✓	✓	✓	✓
MicroSilk	Optional	-	-	-
Tappo in tinta / Color-matched drain / Bonde assortie à la couleur / Desagüe a juego / Farblich abgestimmter Ablauf	✓	✓	✓	✓
Pompe / Pumps / Pompes / Bombas / Pumpen	-	1	1 + 1 Blower	1 + 1 Blower
Riscaldatore 1,3 Kw / 1,3 Kw Heater / Réchauffeur 1,3 Kw / Calentador 1,3 Kw / Heizgerät 1,3 Kw	-	-	-	✓
Lampada RGB / RGB lamp / Lampe RGB / Lámpara RGB / RGB-Lampe	-	-	-	✓

	BASE	EXCLUSIVE	TOP	ULTRA	BASE + MICROSILK	
ETHOS 180	Glossy	01ET32BN 2.400	01ET34BN 4.600	01ET35BN 5.000	01ET36BN 5.800	01ET3MBS 4.400
	Matt	01ET32EN 3.000	01ET34EN 5.200	01ET35EN 5.600	01ET36EN 6.400	01ET3MES 5.000

Pannelli / Panels / Panneaux / Paneles / Paneele

		GLOSSY	MATT
ETHOS 180	Pannello Circolare 180 / 180 Circular Panel / Panneau circulaire 180 / Panel circular 180 / Kreisförmiges 180 Paneel	40E180BN 2.100	40E180EW 2.400

Optional

		Codice	
	Telecomando solo per versione Exclusive, Top e Ultra / Remote control only for Exclusive, Top and Ultra versions / Télécommande uniquement pour les versions Exclusive, Top et Ultra / Mando a distancia solo para las versiones Exclusive, Top y Ultra / Fernbedienung nur für die Versionen Exclusive, Top und Ultra	40TERC00	330
	Colonna di scarico con erogazione / Drain column with dispensing / Colonne d'évacuation avec distribution / Column de desagüe con dispensación / Ablaufsäule mit Auslass	40CER00	130
Rubinetteria D4 / Tapware / Robinetterie / Grifería / Armatur		Cromo Lucido / Polished chrome / Chrome poli / Cromo pulido / Polierter Chrom	40RD4CR0 1.200
		Acciaio Satinato Inox / Satin-finish stainless steel / Acier inox satiné / Acero inox satinado / Satinierter Edelstahl	40RX4IS0 1.250
Rubinetteria D3 + Colonna di Scarico con erogazione / Tapware D3 + Drain column with dispensing / Robinetterie D3 + Colonne d'évacuation avec distribution / Grifería D3 + Column de desagüe con dispensación / Armatur D3 + Ablaufsäule mit Auslass		Cromo Lucido / Polished chrome / Chrome poli / Cromo pulido / Polierter Chrom	40RD3CR0 1.100
		Acciaio Satinato Inox / Satin-finish stainless steel / Acier inox satiné / Acero inox satinado / Satinierter Edelstahl	40RX3IS0 1.150

Quote / Dimensions / Cotes / Cotas / Maße

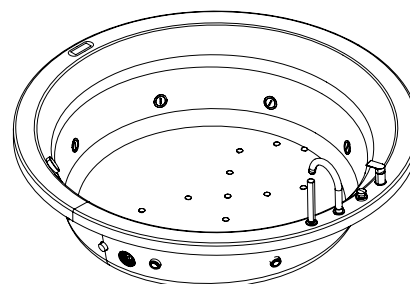
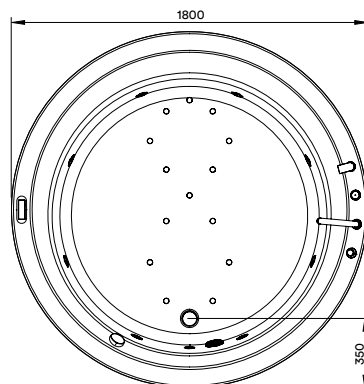

Altea 167 - 177 - 178 - 188

Altea 160

Altea 125

Altea 90° 150

Altea Round 160

Albatros

13

Vasche Altea

ALTEA BATHTUBS



Altea 167 - 177 - 178 - 188
pag. 140



Altea 160
pag. 142



Altea 90° 125
pag. 144



Altea 90° 150
pag. 146



Altea Round 160
pag. 148

Altea 167 177 178 188

DESIGN // ALBATROS R&D



Versione D
/ Right-hand version / Version droite
/ Versión derecha / Rechtsversion

160 x 70 - h 56,5 cm
170 x 70 - h 56,5 cm
170 x 80 - h 56,5 cm
180 x 80 - h 56,5 cm

160x70: 180 lt | max
170x70: 200 lt | max
170x80: 220 lt | max
180x80: 250 lt | max

KG NET
160x70: 51 kg
170x70: 52 kg
170x80: 52 kg
180x80: 67 kg

Finiture / Finishes / Finitions / Acabados / Oberflächen

Molded Matt White
 Molded Glossy White

Pannelli Panels / Panneaux / Paneles / Panele

Molded Matt White
 Molded Glossy White
 Graphite (GP)
 Kashmire (KS)

DOTAZIONI / FEATURES / ÉQUIPEMENTS / EQUIPAMIENTO / AUSSTATTUNG

	BASE	EXCLUSIVE	TOP	ULTRA
Whirlpool Jets	-	7	7	7
Airpool Jets	-	-	12	12
Bocchette / Nozzles / Buses / Boquillas / Düsen	-	FilJets	FilJets	FilJets
System Clean	-	✓	✓	✓
Pannello Digitale / Digital Panel / Panneau numérique / Panel digital / Digitalpanel	-	✓	✓	✓
Linfodrenaggio / Lymphatic drainage / Drainage lymphatique / Drenaje linfático / Lymphdrainage	-	✓	✓	✓
Colonna di scarico con sifone / Drain column with siphon / Colonne d'évacuation avec siphon / Columna de desagüe con sifón / Abflusssäule mit Siphon	✓	✓	✓	✓
MicroSilk	Optional	-	-	-
Tappo in tinta / Color-matched drain / Bonde assortie à la couleur / Desagüe a juego / Farblich abgestimmter Ablauf	✓	✓	✓	✓
Pompe / Pumps / Pompes / Bombas / Pumpen	-	1	1 + 1 Blower	1 + 1 Blower
Riscaldatore 1,3 Kw / 1,3 Kw Heater / Réchauffeur 1,3 Kw / Calentador 1,3 Kw / Heizgerät 1,3 Kw	-	-	-	✓
Lampada RGB / RGB lamp / Lampe RGB / Lámpara RGB / RGB-Lampe	-	-	-	✓

Quote / Dimensions / Cotes / Cotas / Maße

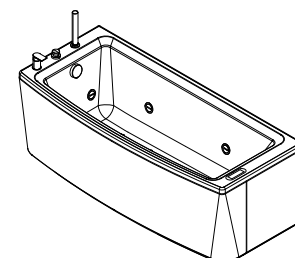
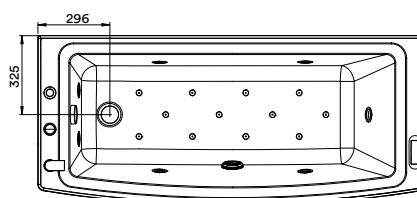

		BASE		EXCLUSIVE		TOP		ULTRA		BASE + MICROSILK	
ALTEA 167 160X70	Glossy	01TH12B*	1.200	01TH14B*	2.850	01TH15B*	3.600	01TH16B*	4.300	01TH1MB*	2.500
	Matt	01TH12E*	1.500	01TH14E*	3.150	01TH15E*	3.900	01TH16E*	4.600	01TH1ME*	2.800
ALTEA 177 170X70	Glossy	01TH22B*	1.250	01TH24B*	2.900	01TH25B*	3.650	01TH26B*	4.350	01TH2MB*	2.550
	Matt	01TH22E*	1.550	01TH24E*	3.200	01TH25E*	3.950	01TH26E*	4.650	01TH2ME*	2.850
ALTEA 178 170X80	Glossy	01TH32B*	1.250	01TH34B*	2.900	01TH35B*	3.650	01TH36B*	4.350	01TH3MB*	2.550
	Matt	01TH32E*	1.550	01TH34E*	3.200	01TH35E*	3.950	01TH36E*	4.650	01TH3ME*	2.850
ALTEA 188 180X80	Glossy	01TH42B*	1.300	01TH44B*	2.950	01TH45B*	3.700	01TH46B*	4.400	01TH4MB*	2.600
	Matt	01TH42E*	1.600	01TH44E*	3.250	01TH45E*	4.000	01TH46E*	4.700	01TH4ME*	2.900

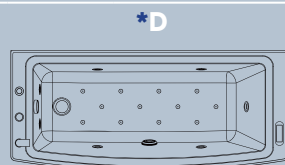
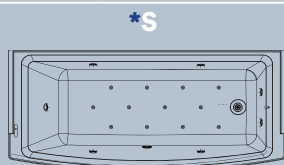

Pannelli / Panels /
Panneaux / Paneles
/ Paneele

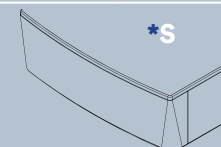
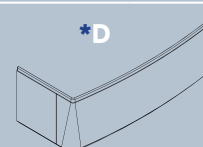

Pannelli / Panels /
Panneaux / Paneles /
Paneele

GLOSSY

MATT

GRAPHITE

KASHMIR

ALTEA 167		40T67*BN	600	40T67*EW	700	40T67*GP	1.300	40T67*KS	1.300
		40TL67*BN	900	40TL67*EW	1.000	40TL67*GP	1.900	40TL67*KS	1.900
ALTEA 177		40T77*BN	600	40T77*EW	700	40T77*GP	1.300	40T77*KS	1.300
		40TL77*BN	900	40TL77*EW	1.000	40TL77*GP	1.900	40TL77*KS	1.900
ALTEA 178		40T78*BN	600	40T78*EW	700	40T78*GP	1.300	40T78*KS	1.300
		40TL78*BN	900	40TL78*EW	1.000	40TL78*GP	1.900	40TL78*KS	1.900
ALTEA 188		40T88*BN	600	40T88*EW	700	40T88*GP	1.300	40T88*KS	1.300
		40TL88*BN	900	40TL88*EW	1.000	40TL88*GP	1.900	40TL88*KS	1.900

Optional

Codice

Telecomando solo per versione Exclusive, Top e Ultra / Remote control only for Exclusive, Top and Ultra versions / Télécommande uniquement pour les versions Exclusive, Top et Ultra / Mando a distancia solo para las versiones Exclusive, Top y Ultra / Fernbedienung nur für die Versionen Exclusive, Top und Ultra		40TERC00	330	
Colonna di scarico con erogazione / Drain column with dispensing / Colonne d'évacuation avec distribution / Column de desagüe con dispensación / Ablaufsäule mit Auslass		40CER00	130	
Rubinetteria D4 / Tapware / Robinetterie / Grifería / Armatur		Cromo Lucido / Polished chrome / Chrome poli / Cromo pulido / Polierter Chrom	40RD4CRO	1.200
		Acciaio Satinato Inox / Satin-finish stainless steel / Acier inox satiné / Acero inox satinado / Satinierter Edelstahl	40RX4ISO	1.250
Rubinetteria D3 + Colonna di Scarico con erogazione / Tapware D3 + Drain column with dispensing / Robinetterie D3 + Colonne d'évacuation avec distribution / Grifería D3 + Column de desagüe con dispensación / Armatur D3 + Ablaufsäule mit Auslass		Cromo Lucido / Polished chrome / Chrome poli / Cromo pulido / Polierter Chrom	40RD3CRO	1.100
		Acciaio Satinato Inox / Satin-finish stainless steel / Acier inox satiné / Acero inox satinado / Satinierter Edelstahl	40RX3ISO	1.150

Altea 160

DESIGN // ALBATROS R&D



Versione D
/ Right-hand version / Version droite
/ Versión derecha / Rechtsversion

 160 x 100 - h 56,5 cm

 250 lt | max

 57 kg

Finiture / Finishes
/ Finitions / Acabados /
Oberflächen

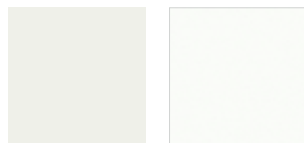

**Molded
Glossy White**

**Molded Matt
White**

**Pannelli Panels /
Panneaux / Paneles /
Pannele**

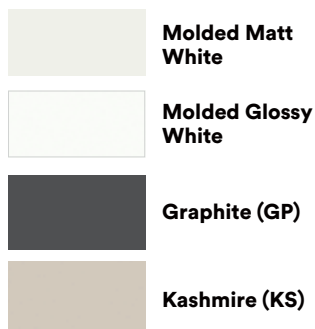













**Molded Matt
White**

**Molded Glossy
White**

Graphite (GP)

Kashmire (KS)

**DOTAZIONI / FEATURES / ÉQUIPEMENTS /
EQUIPAMIENTO / AUSSTATTUNG**

	BASE	EXCLUSIVE	TOP	ULTRA
 Whirlpool Jets	-	6	6	6
 Airpool Jets	-	-	12	12
 Bocchette / Nozzles / Buses / Boquillas / Düsen	-	FilJets	FilJets	FilJets
 System Clean	-	✓	✓	✓
 Pannello Digitale / Digital Panel / Panneau numérique / Panel digital / Digitalpanel	-	✓	✓	✓
 Linfodrenaggio / Lymphatic drainage / Drainage lymphatique / Drenaje linfático / Lymphdrainage	-	✓	✓	✓
 Colonna di scarico con sifone / Drain column with siphon / Colonne d'évacuation avec siphon / Columna de desagüe con sifón / Ablaufsäule mit Siphon	✓	✓	✓	✓
 MicroSilk	Optional	-	-	-
 Tappo in tinta / Color-matched drain / Bonde assortie à la couleur / Desagüe a juego / Farblich abgestimmter Ablauf	✓	✓	✓	✓
 Pompe / Pumps / Pompes / Bombas / Pumpen	-	1	1 + 1 Blower	1 + 1 Blower
 Riscaldatore 1,3 Kw / 1,3 Kw Heater / Réchauffeur 1,3 Kw / Calentador 1,3 Kw / Heizgerät 1,3 Kw	-	-	-	✓
 Lampada RGB / RGB lamp / Lampe RGB / Lámpara RGB / RGB-Lampe	-	-	-	✓

	BASE	EXCLUSIVE	TOP	ULTRA	BASE + MICROSILK
Glossy	01TH72B* 1.350	01TH74B* 3.000	01TH75B* 3.750	01TH76B* 4.450	01TH7MB* 2.900

ALTEA 160

Matt	01TH72E* 1.650	01TH74E* 3.300	01TH75E* 4.050	01TH76E* 4.750	01TH7ME* 3.200
------	----------------	----------------	----------------	----------------	----------------

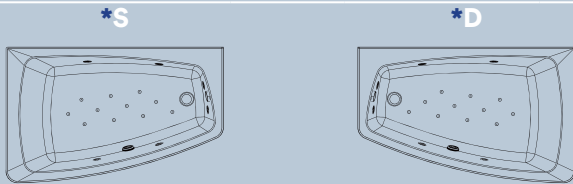

Pannelli / Panels / Panneaux / Paneles / Panele

GLOSSY

MATT

GRAPHITE

KASHMIR

ALTEA 160

40T67*BN 600	40T67*EW 700	40T67*GP 1.300	40T67*KS 1.300
--------------	--------------	----------------	----------------



Optional

Codice

Telecomando solo per versione Exclusive, Top e Ultra / Remote control only for Exclusive, Top and Ultra versions / Télécommande uniquement pour les versions Exclusive, Top et Ultra / Mando a distancia solo para las versiones Exclusive, Top y Ultra / Fernbedienung nur für die Versionen Exclusive, Top und Ultra	40TERC00	330
Colonna di scarico con erogazione / Drain column with dispensing / Colonne d'évacuation avec distribution / Column de desagüe con dispensación / Ablaufsäule mit Auslass	40CER00	130
Rubinetteria D4 / Tapware / Robinetterie / Grifería / Armatur	Cromo Lucido / Polished chrome / Chrome poli / Cromo pulido / Polierter Chrom	40RD4CRO 1.200
	Acciaio Satinato Inox / Satin-finish stainless steel / Acier inox satiné / Acero inox satinado / Satinierter Edelstahl	40RX4IS0 1.250
Rubinetteria D3 + Colonna di Scarico con erogazione / Tapware D3 + Drain column with dispensing / Robinetterie D3 + Colonne d'évacuation avec distribution / Grifería D3 + Column de desagüe con dispensación / Armatur D3 + Ablaufsäule mit Auslass	Cromo Lucido / Polished chrome / Chrome poli / Cromo pulido / Polierter Chrom	40RD3CRO 1.100
	Acciaio Satinato Inox / Satin-finish stainless steel / Acier inox satiné / Acero inox satinado / Satinierter Edelstahl	40RX3IS0 1.150

Quote / Dimensions / Cotes / Cotas / Maße

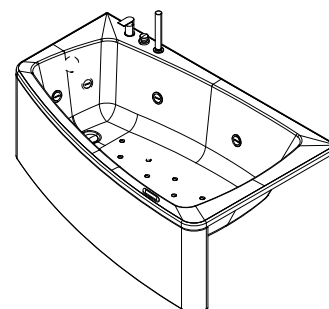
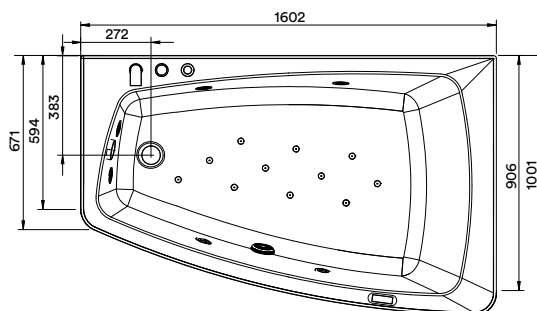

Altea 90° 125

DESIGN // ALBATROS R&D

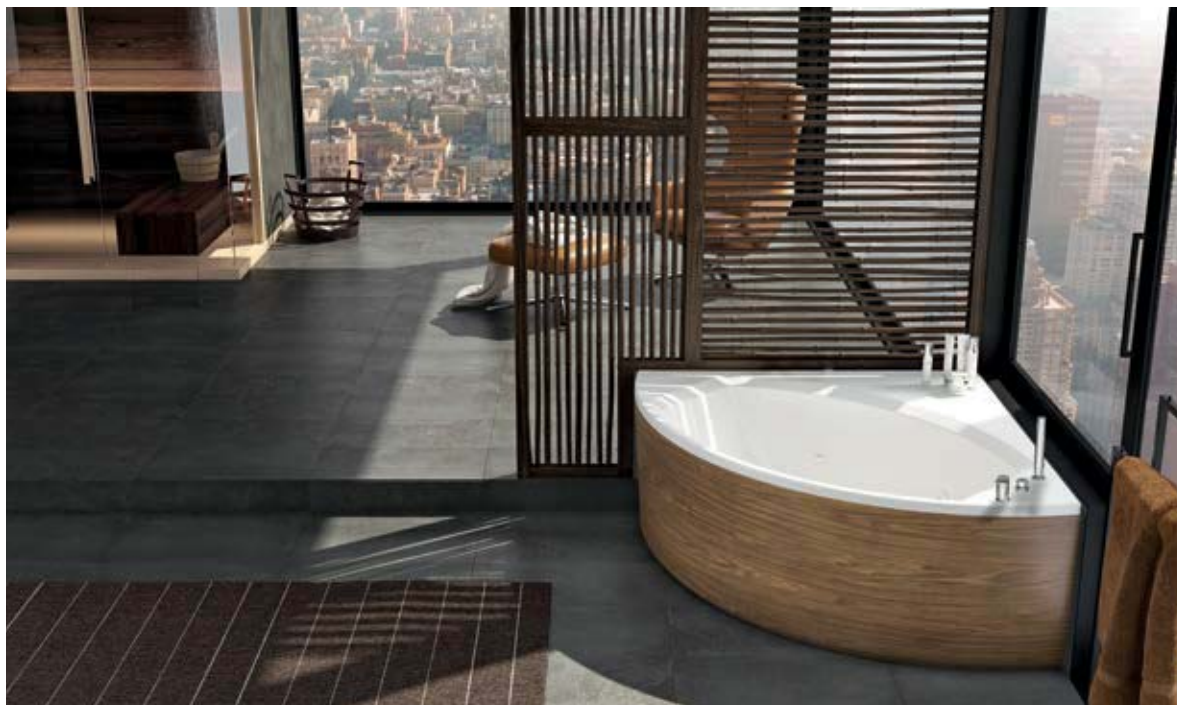

 **125 x 125 - h 56,5 cm**

 **170 lt | max**

 **61 kg**

Finiture / Finishes / Finitions / Acabados / Oberflächen

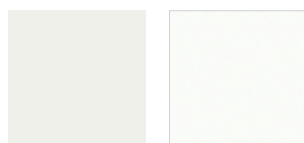

**Molded
Glossy White**

**Molded Matt
White**

Pannelli Panels / Panneaux / Paneles / Panele

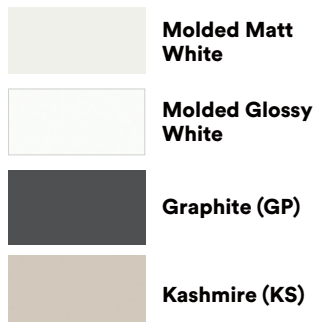













**Molded Matt
White**

**Molded Glossy
White**

Graphite (GP)



Kashmire (KS)

DOTAZIONI / FEATURES / ÉQUIPEMENTS / EQUIPAMIENTO / AUSSTATTUNG

	BASE	EXCLUSIVE	TOP	ULTRA
 Whirlpool Jets	-	7	7	7
 Airpool Jets	-	-	12	12
 Bocchette / Nozzles / Buses / Boquillas / Düsen	-	FilJets	FilJets	FilJets
 System Clean	-	✓	✓	✓
 Pannello Digitale / Digital Panel / Panneau numérique / Panel digital / Digitalpanel	-	✓	✓	✓
 Linfodrenaggio / Lymphatic drainage / Drainage lymphatique / Drenaje linfático / Lymphdrainage	-	✓	✓	✓
 Colonna di scarico con sifone / Drain column with siphon / Colonne d'évacuation avec siphon / Columna de desagüe con sifón / Ablaufsäule mit Siphon	✓	✓	✓	✓
 MicroSilk	Optional	-	-	-
 Tappo in tinta / Color-matched drain / Bonde assortie à la couleur / Desagüe a juego / Farblich abgestimmter Ablauf	✓	✓	✓	✓
 Pompe / Pumps / Pompes / Bombas / Pumpen	-	1	1 + 1 Blower	1 + 1 Blower
 Riscaldatore 1,3 Kw / 1,3 Kw Heater / Réchauffeur 1,3 Kw / Calentador 1,3 Kw / Heizgerät 1,3 Kw	-	-	-	✓
 Lampada RGB / RGB lamp / Lampe RGB / Lámpara RGB / RGB-Lampe	-	-	-	✓

	BASE	EXCLUSIVE	TOP	ULTRA	BASE + MICROSILK
ALTEA 125	Glossy 01TH52BS 1.600	01TH54BS 3.200	01TH55BS 4.100	01TH56BS 4.800	01TH5MBS 3.300
	Matt 01TH52ES 1.800	01TH54ES 3.400	01TH55ES 4.300	01TH56ES 5.000	01TH5MES 3.500

Pannelli / Panels / Panneaux / Paneles / Panele	GLOSSY	MATT	GRAPHITE	KASHMIR
ALTEA 125 Pannello Angolare 125 / Corner Panel 125 / Panneau d'angle 125 / Panel de esquina 125 / Eckpaneel 125	40T125BN 450	40T125EW 550	40T125GP 1.100	40T125KS 1.100

Optional	Codice		
Telecomando solo per versione Exclusive, Top e Ultra / Remote control only for Exclusive, Top and Ultra versions / Télécommande uniquement pour les versions Exclusive, Top et Ultra / Mando a distancia solo para las versiones Exclusive, Top y Ultra / Fernbedienung nur für die Versionen Exclusive, Top und Ultra	40TERC00	330	
Colonna di scarico con erogazione / Drain column with dispensing / Colonne d'évacuation avec distribution / Column de desagüe con dispensación / Ablaufsäule mit Auslass	40CER00	130	
Rubineria D4 / Tapware / Robinetterie / Grifería / Armatur	 Cromo Lucido / Polished chrome / Chrome poli / Cromo pulido / Polierter Chrom	40RD4CR0	1.200
	Acciaio Satinato Inox / Satin-finish stainless steel / Acier inox satiné / Acero inox satinado / Satinierter Edelstahl	40RX4IS0	1.250
Rubineria D3 + Colonna di Scarico con erogazione / Tapware D3 + Drain column with dispensing / Robinetterie D3 + Colonne d'évacuation avec distribution / Grifería D3 + Column de desagüe con dispensación / Armatur D3 + Ablaufsäule mit Auslass	 Cromo Lucido / Polished chrome / Chrome poli / Cromo pulido / Polierter Chrom	40RD3CR0	1.100
	Acciaio Satinato Inox / Satin-finish stainless steel / Acier inox satiné / Acero inox satinado / Satinierter Edelstahl	40RX3IS0	1.150

Quote / Dimensions / Cotes / Cotas / Maße

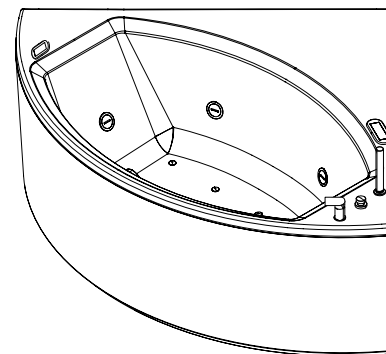
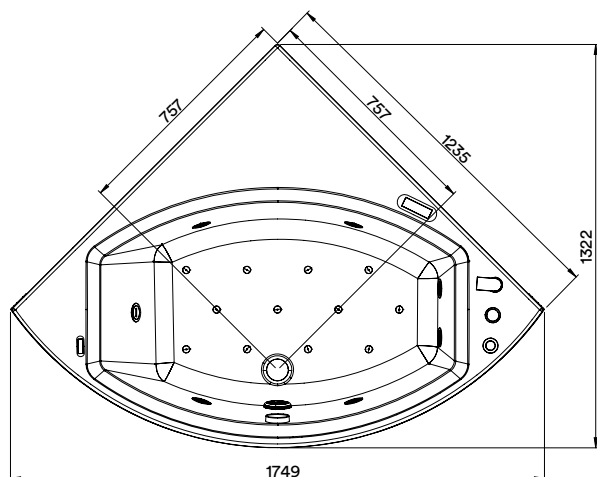

Altea 90° 150

DESIGN // ALBATROS R&D



 **150 x 150 - h 56,5 cm**

 **310 lt | max**

 **60 kg**

Finiture / Finishes
/ Finitions / Acabados /
Oberflächen

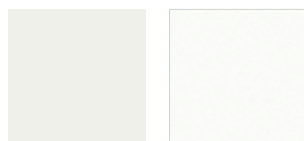

**Molded
Glossy White**

**Molded Matt
White**

**Pannelli Panels /
Panneaux / Paneles /
Panele**



**Molded Matt
White**

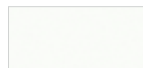

**Molded Glossy
White**















Graphite (GP)



Kashmir (KS)

DOTAZIONI / FEATURES / ÉQUIPEMENTS / EQUIPAMIENTO / AUSSTATTUNG

	BASE	EXCLUSIVE	TOP	ULTRA
 Whirlpool Jets	-	6	6	6
 Airpool Jets	-	-	12	12
 Bocchette / Nozzles / Buses / Boquillas / Düsen	-	FilJets	FilJets	FilJets
 System Clean	-	✓	✓	✓
 Pannello Digitale / Digital Panel / Panneau numérique / Panel digital / Digitalpanel	-	✓	✓	✓
 Linfodrenaggio / Lymphatic drainage / Drainage lymphatique / Drenaje linfático / Lymphdrainage	-	✓	✓	✓
 Colonna di scarico con sifone / Drain column with siphon / Colonne d'évacuation avec siphon / Columna de desagüe con sifón / Ablaufsäule mit Siphon	✓	✓	✓	✓
 MicroSilk	Optional	-	-	-
 Tappo in tinta / Color-matched drain / Bonde assortie à la couleur / Desagüe a juego / Farblich abgestimmter Ablauf	✓	✓	✓	✓
 Pompe / Pumps / Pompes / Bombas / Pumpen	-	1	1 + 1 Blower	1 + 1 Blower
 Riscaldatore 1,3 Kw / 1,3 Kw Heater / Réchauffeur 1,3 Kw / Calentador 1,3 Kw / Heizgerät 1,3 Kw	-	-	-	✓
 Lampada RGB / RGB lamp / Lampe RGB / Lámpara RGB / RGB-Lampe	-	-	-	✓

	BASE	EXCLUSIVE	TOP	ULTRA	BASE + MICROSILK					
	Glossy 01TH62BS	1.700	01TH64BS	3.600	01TH65BS	4.200	01TH66BS	4.950	01TH6MBS	3.400

ALTEA 150

	Matt 01TH62ES	1.900	01TH64ES	3.800	01TH65ES	4.400	01TH66ES	5.150	01TH6MES	3.600
--	---------------	-------	----------	-------	----------	-------	----------	-------	----------	-------

Pannelli / Panels / Panneaux / Paneles / Paneele

		GLOSSY	MATT	GRAPHITE	KASHMIR				
ALTEA 150	Pannello Angolare 150 / Corner Panel 150 / Panneau d'angle 150 / Panel de esquina 150 / Eckpaneel 150	40T150BN	450	40T150EW	550	40T150GP	1.200	40T150KS	1.200

Optional

		Codice	
	Telecomando solo per versione Exclusive, Top e Ultra / Remote control only for Exclusive, Top and Ultra versions / Télécommande uniquement pour les versions Exclusive, Top et Ultra / Mando a distancia solo para las versiones Exclusive, Top y Ultra / Fernbedienung nur für die Versionen Exclusive, Top und Ultra	40TERC00	330
	Colonna di scarico con erogazione / Drain column with dispensing / Colonne d'évacuation avec distribution / Column de desagüe con dispensación / Ablaufsäule mit Auslass	40CER00	130
Rubineria D4 / Tapware / Robinetterie / Grifería / Armatur		Cromo Lucido / Polished chrome / Chrome poli / Cromo pulido / Polierter Chrom 40RD4CRO	1.200
		Acciaio Satinato Inox / Satin-finish stainless steel / Acier inox satiné / Acero inox satinado / Satinierter Edelstahl 40RX4ISO	1.250
Rubineria D3 + Colonna di Scarico con erogazione / Tapware D3 + Drain column with dispensing / Robinetterie D3 + Colonne d'évacuation avec distribution / Grifería D3 + Column de desagüe con dispensación / Armatur D3 + Ablaufsäule mit Auslass		Cromo Lucido / Polished chrome / Chrome poli / Cromo pulido / Polierter Chrom 40RD3CRO	1.100
		Acciaio Satinato Inox / Satin-finish stainless steel / Acier inox satiné / Acero inox satinado / Satinierter Edelstahl 40RX3ISO	1.150

Quote / Dimensions / Cotes / Cotas / Maße

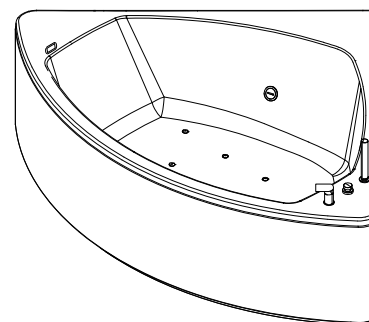
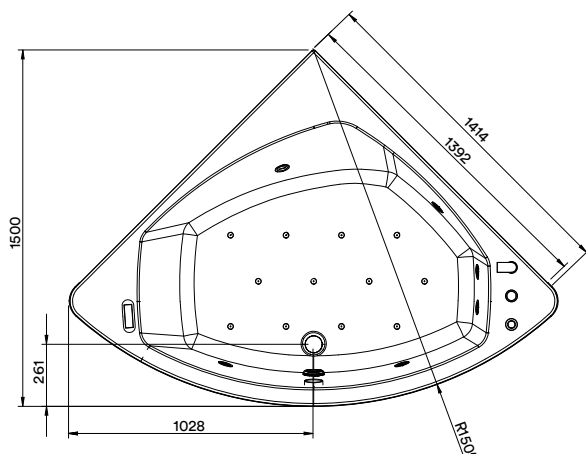

Altea Round 160

DESIGN // ALBATROS R&D











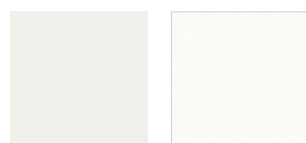



 Ø 161 - h 64 cm

 380 lt | max

 65 kg

Finiture / Finishes
/ Finitions / Acabados /
Oberflächen

**Molded
Glossy White**
**Molded Matt
White**
**DOTAZIONI / FEATURES / ÉQUIPEMENTS /
EQUIPAMIENTO / AUSSTATTUNG**

	BASE	EXCLUSIVE	TOP	ULTRA
 Whirlpool Jets	-	6	6	6
 Airpool Jets	-	-	12	12
 Bocchette / Nozzles / Buses / Boquillas / Düsen	-	FilJets	FilJets	FilJets
 System Clean	-	✓	✓	✓
 Pannello Digitale / Digital Panel / Panneau numérique / Panel digital / Digitalpanel	-	✓	✓	✓
 Linfodrenaggio / Lymphatic drainage / Drainage lymphatique / Drenaje linfático / Lymphdrainage	-	✓	✓	✓
 Colonna di scarico con sifone / Drain column with siphon / Colonne d'évacuation avec siphon / Columna de desagüe con sifón / Ablaufsäule mit Siphon	✓	✓	✓	✓
 MicroSilk	Optional	-	-	-
 Tappo in tinta / Color-matched drain / Bonde assortie à la couleur / Desagüe a juego / Farblich abgestimmter Ablauf	✓	✓	✓	✓
 Pompe / Pumps / Pompes / Bombas / Pumpen	-	1	1 + 1 Blower	1 + 1 Blower
 Riscaldatore 1,3 Kw / 1,3 Kw Heater / Réchauffeur 1,3 Kw / Calentador 1,3 Kw / Heizgerät 1,3 Kw	-	-	-	✓
 Lampada RGB / RGB lamp / Lampe RGB / Lámpara RGB / RGB-Lampe	-	-	-	✓

	BASE	EXCLUSIVE	TOP	ULTRA	BASE + MICROSILK
ALTEA ROUND 160	Glossy 01TH82BN 2.400	01TH84BN 4.300	01TH85BN 5.200	01TH86BN 5.800	01TH8MBS 3.600
	Matt 01TH82EN 3.000	01TH84EN 4.900	01TH85EN 5.800	01TH86EN 6.400	01TH8MES 4.200

Optional

Codice

Telecomando solo per versione Exclusive, Top e Ultra / Remote control only for Exclusive, Top and Ultra versions / Télécommande uniquement pour les versions Exclusive, Top et Ultra / Mando a distancia solo para las versiones Exclusive, Top y Ultra / Fernbedienung nur für die Versionen Exclusive, Top und Ultra		40TERC00	330
Colonna di scarico con erogazione / Drain column with dispensing / Colonne d'évacuation avec distribution / Column de desagüe con dispensación / Ablaufsäule mit Auslass		40CER00	130
Rubinetteria D4 / Tapware / Robinetterie / Grifería / Armatur		Cromo Lucido / Polished chrome / Chrome poli / Cromo pulido / Polierter Chrom	40RD4CR0 1.200
		Acciaio Satinato Inox / Satin-finish stainless steel / Acier inox satiné / Acero inox satinado / Satinierter Edelstahl	40RX4IS0 1.250
Rubinetteria D3 + Colonna di Scarico con erogazione / Tapware D3 + Drain column with dispensing / Robinetterie D3 + Colonne d'évacuation avec distribution / Grifería D3 + Columna de desagüe con dispensación / Armatur D3 + Ablaufsäule mit Auslass		Cromo Lucido / Polished chrome / Chrome poli / Cromo pulido / Polierter Chrom	40RD3CR0 1.100
		Acciaio Satinato Inox / Satin-finish stainless steel / Acier inox satiné / Acero inox satinado / Satinierter Edelstahl	40RX3IS0 1.150

Quote / Dimensions / Cotes / Cotas / Maße

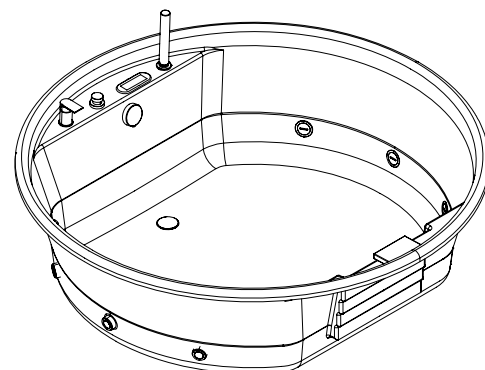
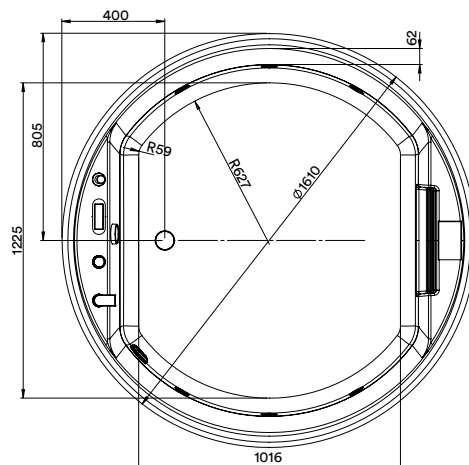

Idea F Oval
Idea F Rectangular
Idea 147 - 157 - 167 - 177
Idea 90° 140
Idea 158

Albatros

14

Vasche Idea

IDEA BATHTUBS



Idea F Oval
pag. 152



Idea F Rectangular
pag. 154



Idea 147 - 157 - 167 - 177
pag. 156



Idea 90° 140
pag. 158



Idea 158
pag. 160

Idea Freestanding Oval



DESIGN // ALBATROS R&D



 170 x 80 - h 61 cm

 240 lt | max

 45 kg

DOTAZIONI / FEATURES / ÉQUIPEMENTS / EQUIPAMIENTO / AUSSTATTUNG	BASE	EXCLUSIVE
 Piletta Sifonata / Siphon Drain / Bonde siphonnée / Desagüe sifonado / Siphonablauf	✓	✓
 Airpool Jets	-	✓
 Telecomando per Airpool / Remote control for Airpool / Télécommande pour Airpool / Mando a distancia para Airpool / Fernbedienung für Airpool	-	✓

Finiture / Finishes / Finitions / Acabados / Oberflächen

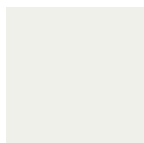

**Molded
Glossy White**

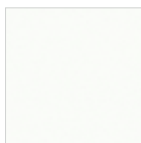

**Molded Matt
White**

Quote / Dimensions / Cotes / Cotas / Maße

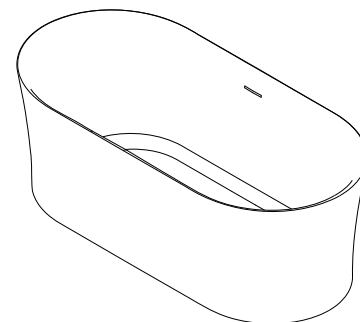
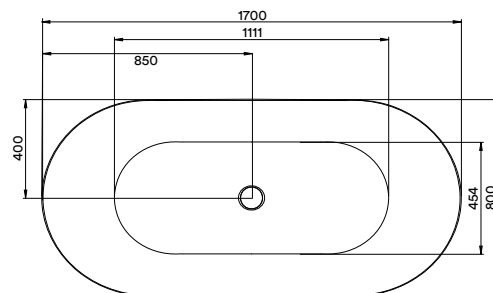

IDEA F OVAL

	BASE		EXCLUSIVE	
Glossy	01IDB6NF	1.950	01IDB7NF	2.700
Matt	01IDE6NF	2.050	01IDE7NF	2.800



Idea Freestanding Rectangular



DESIGN // ALBATROS R&D



 170 x 80 - h 61 cm

 240 lt | max

 45 kg

DOTAZIONI / FEATURES / ÉQUIPEMENTS / EQUIPAMIENTO / AUSSTATTUNG	BASE	EXCLUSIVE
 Piletta Sifonata / Siphon Drain / Bonde siphonnée / Desagüe sifonado / Siphonablauf	✓	✓
 Airpool Jets	-	✓
 Telecomando per Airpool / Remote control for Airpool / Télécommande pour Airpool / Mando a distancia para Airpool / Fernbedienung für Airpool	-	✓

Finiture / Finishes / Finitions / Acabados / Oberflächen

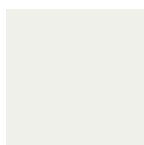

**Molded
Glossy White**

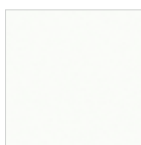

**Molded Matt
White**

Quote / Dimensions / Cotes / Cotas / Maße

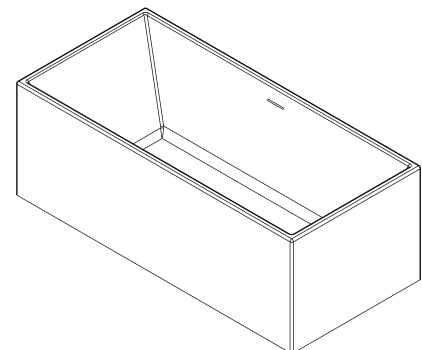
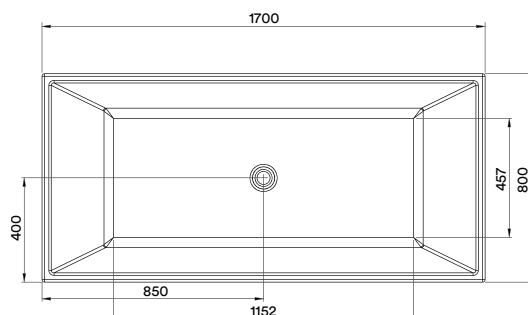

IDEA F RECTANGULAR

	BASE		EXCLUSIVE	
Glossy	01IDB9NF	2.050	01IDB8NF	2.850
Matt	01IDE9NF	2.150	01IDE8NF	2.950



Idea 147 157 167 177

DESIGN // ALBATROS R&D







Versione S
/ Left-hand version / Version gauche
/ Versión izquierda / Linke Ausführung

 140 x 70 - h 56,5 cm
150 x 70 - h 56,5 cm
160 x 70 - h 56,5 cm
170 x 70 - h 56,5 cm

 140x70: 157 lt | max
150x70: 173 lt | max
160x70: 185 lt | max
170x70: 188 lt | max

 **KG NET**
140x70: 42 kg
150x70: 43 kg
160x70: 52 kg
170x70: 67 kg

DOTAZIONI / FEATURES / ÉQUIPEMENTS / EQUIPAMIENTO / AUSSTATTUNG

	BASE	EXCLUSIVE
 Whirlpool Jets	-	6
 Bocchette / Nozzles / Buses / Boquillas / Düsen	-	CromJets
 Colonna di scarico con sifone / Drain column with siphon / Colonne d'évacuation avec siphon / Columna de desagüe con sifón / Abflusssäule mit Siphon	✓	✓
 ON/OFF	-	✓

Finiture / Finishes / Finitions / Acabados / Oberflächen

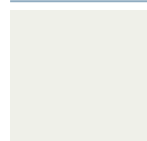

Molded Glossy White

Pannelli Panels / Panneaux / Paneles / Paneele

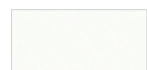

Molded Glossy White

Quote / Dimensions / Cotes / Cotas / Maße

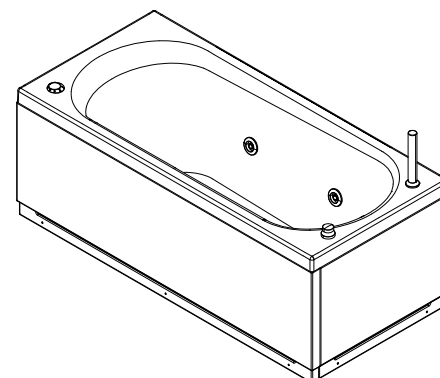
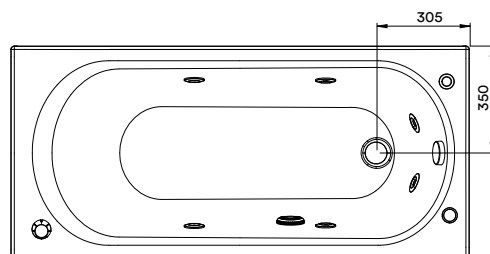

//Versione SX/LH version
Per la versione DX, la disposizione è speculare
For the RH version, reverse the drawing

		BASE		EXCLUSIVE	
IDEA 147 140X70	Glossy	01ID12BN	970	01ID13B*	1.800
IDEA 157 150X70	Glossy	01ID22BN	970	01ID23B*	1.800
IDEA 167 160X70	Glossy	01ID32BN	980	01ID33B*	1.810
IDEA 177 170X70	Glossy	01ID42BN	1.100	01ID43B*	1.830

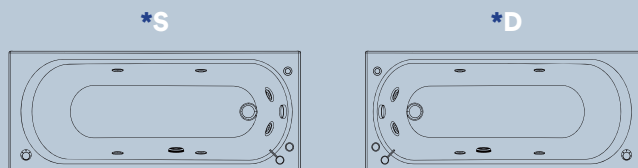

Pannelli / Panels / Panneaux / Paneles / Paneele

GLOSSY

IDEA 147		40147BNC	250
		40147LBNC	350
IDEA 157		40157BNC	250
		40157LBNC	350
IDEA 167		40167BNC	260
		40167LBNC	360
IDEA 177		40177BNC	270
		40177LBNC	370

Optional

Codice

Colonna di scarico con erogazione / Drain column with dispensing / Colonne d'évacuation avec distribution / Column de desagüe con dispensación / Ablaufsäule mit Auslass		40CER00	130
Rubinetteria D4 / Tapware / Robinetterie / Grifería / Armatur		Cromo Lucido / Polished chrome / Chrome poli / Cromo pulido / Poliierter Chrom	40RD4CR0 1.200
		Acciaio Satinato Inox / Satin-finish stainless steel / Acier inox satiné / Acero inox satinado / Satinierter Edelstahl	40RX4IS0 1.250
Rubinetteria D3 + Colonna di Scarico con erogazione / Tapware D3 + Drain column with dispensing / Robinetterie D3 + Colonne d'évacuation avec distribution / Grifería D3 + Column de desagüe con dispensación / Armatur D3 + Ablaufsäule mit Auslass		Cromo Lucido / Polished chrome / Chrome poli / Cromo pulido / Poliierter Chrom	40RD3CR0 1.100
		Acciaio Satinato Inox / Satin-finish stainless steel / Acier inox satiné / Acero inox satinado / Satinierter Edelstahl	40RX3IS0 1.150

Idea 90° 140

DESIGN // ALBATROS R&D







 **140 x 140 - h 56,5 cm**

 **289 lt | max**

 **57 kg**

DOTAZIONI / FEATURES / ÉQUIPEMENTS / EQUIPAMIENTO / AUSSTATTUNG

	BASE	EXCLUSIVE
 Whirlpool Jets	-	6
 Bocchette / Nozzles / Buses / Boquillas / Düsen	-	CromJets
 Colonna di scarico con sifone / Drain column with siphon / Colonne d'évacuation avec siphon / Columna de desagüe con sifón / Abflusssäule mit Siphon	✓	✓
 ON/OFF	-	✓

Finiture / Finishes / Finitions / Acabados / Oberflächen

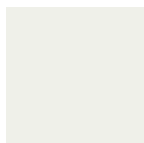

Molded Glossy White

Pannelli Panels / Panneaux / Paneles / Paneele

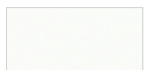

Molded Glossy White

Quote / Dimensions / Cotes / Cotas / Maße

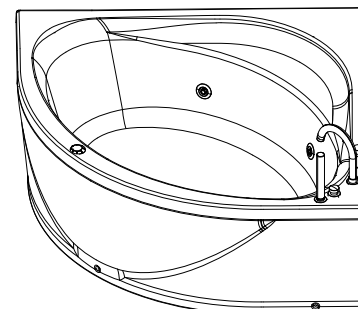
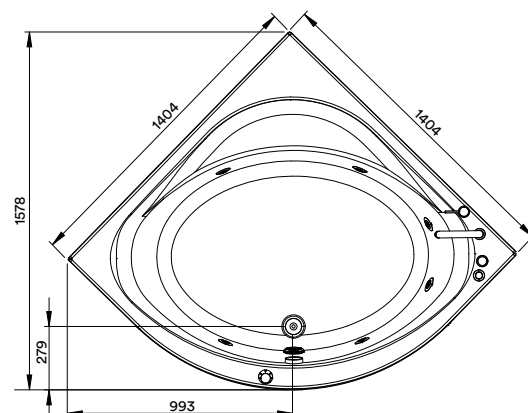

		BASE		EXCLUSIVE	
IDEA 140		Glossy	01ID52BN	1.620	01ID53BS 2.460



Pannelli / Panels / Panneaux / Paneles / Paneele

GLOSSY

IDEA 140	Pannello Angolare 140 / Corner Panel 140 / Panneau d'angle 140 / Panel de esquina 140 / Eckpaneel 140			40A40BNC	390
----------	---	--	--	----------	-----

Optional

Codice

Colonna di scarico con erogazione / Drain column with dispensing / Colonne d'évacuation avec distribution / Column de desagüe con dispensación / Ablaufsäule mit Auslass				40CER00	130
Rubinetteria D4 / Tapware / Robinetterie / Grifería / Armatur		Cromo Lucido / Polished chrome / Chrome poli / Cromo pulido / Polierter Chrom		40RD4CR0	1.200
		Acciaio Satinato Inox / Satin-finish stainless steel / Acier inox satiné / Acero inox satinado / Satinierter Edelstahl		40RX4IS0	1.250
Rubinetteria D3 + Colonna di Scarico con erogazione / Tapware D3 + Drain column with dispensing / Robinetterie D3 + Colonne d'évacuation avec distribution / Grifería D3 + Column de desagüe con dispensación / Armatur D3 + Ablaufsäule mit Auslass		Cromo Lucido / Polished chrome / Chrome poli / Cromo pulido / Polierter Chrom		40RD3CR0	1.100
		Acciaio Satinato Inox / Satin-finish stainless steel / Acier inox satiné / Acero inox satinado / Satinierter Edelstahl		40RX3IS0	1.150

Idea 158

DESIGN // ALBATROS R&D







Versione S
 / Left-hand version / Version gauche
 / Versión izquierda / Linke Ausführung

 **150 x 80 - h 56,5 cm**

 **202 lt | max**

 **59 kg**

DOTAZIONI / FEATURES / ÉQUIPEMENTS / EQUIPAMIENTO / AUSSTATTUNG

	BASE	EXCLUSIVE
 Whirlpool Jets	-	6
 Bocchette / Nozzles / Buses / Boquillas / Düsen	-	CromJets
 Colonna di scarico con sifone / Drain column with siphon / Colonne d'évacuation avec siphon / Columna de desagüe con sifón / Abflausäule mit Siphon	✓	✓
 ON/OFF	-	✓

Finiture / Finishes / Finitions / Acabados / Oberflächen

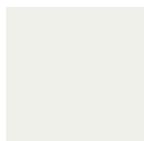

Molded Glossy White

Pannelli Panels / Panneaux / Paneles / Paneele

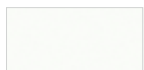

Molded Glossy White

Quote / Dimensions / Cotes / Cotas / Maße

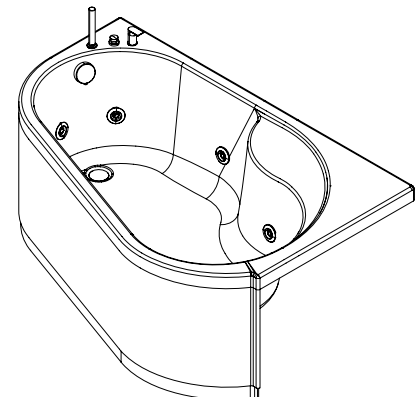
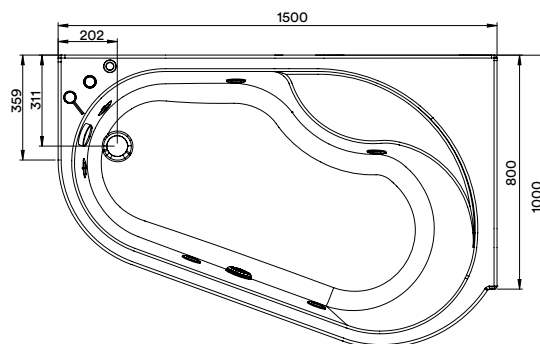

//Versione DX/RH version
 Per la versione SX, la disposizione è speculare
 For the LH version, reverse the drawing

		BASE		EXCLUSIVE	
IDEA 158		Glossy	OID62B*	1.330	01ID63B* 2.180

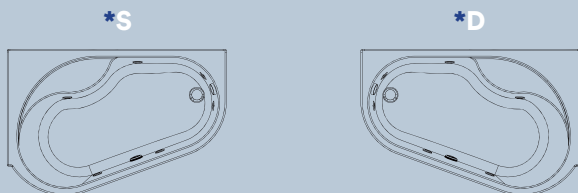

Pannelli / Panels / Panneaux / Paneles / Paneele

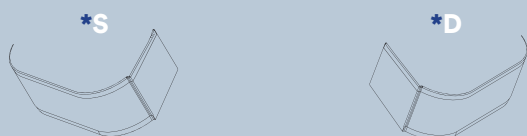

GLOSSY

IDEA 158	Pannello Asimmetrico 150 / Asymmetrical Panel 150 / Panneau asymétrique 150 / Panel asimétrico 150 / Asymmetrisches Panel 150	40S50*BN	380
----------	---	----------	-----



Optional

Codice

Colonna di scarico con erogazione / Drain column with dispensing / Colonne d'évacuation avec distribution / Column de desagüe con dispensación / Ablaufsäule mit Auslass		40CER00	130
Rubinetteria D4 / Tapware / Robinetterie / Grifería / Armatur		Cromo Lucido / Polished chrome / Chrome poli / Cromo pulido / Polierter Chrom	40RD4CR0 1.200
		Acciaio Satinato Inox / Satin-finish stainless steel / Acier inox satiné / Acero inox satinado / Satinierter Edelstahl	40RX4IS0 1.250
Rubinetteria D3 + Colonna di Scarico con erogazione / Tapware D3 + Drain column with dispensing / Robinetterie D3 + Colonne d'évacuation avec distribution / Grifería D3 + Column de desagüe con dispensación / Armatur D3 + Ablaufsäule mit Auslass		Cromo Lucido / Polished chrome / Chrome poli / Cromo pulido / Polierter Chrom	40RD3CR0 1.100
		Acciaio Satinato Inox / Satin-finish stainless steel / Acier inox satiné / Acero inox satinado / Satinierter Edelstahl	40RX3IS0 1.150

Albatros

15

Funzioni Sauna e Hammam

/ Sauna and Hammam functions / Fonctions Sauna et Hammam
Funciones Sauna y Hammam / Sauna- und Hammam-Funktionen

pag. 164

Funzioni Minipiscine

/ SPA functions / Fonctions des mini-piscines
/ Funciones de las minipiscinas / Funktionen der Minipools

pag. 166

Green Plus

pag. 174

Cura e Manutezione

/ Care and maintenance / Entretien et maintenance
/ Cuidado y mantenimiento / Pflege und Wartung

pag. 176

Condizioni Generali di vendita

/ General sales conditions / Conditions générales
/ General sales conditions / Allgemeine Geschäftsbedingungen

pag. 178

Funzioni Sauna e Hammam

/ Sauna and Hammam functions / Fonctions Sauna et Hammam / Funciones Sauna y Hammam / Sauna- und Hammam-Funktionen



I benefici della sauna secca

Un'esperienza di profondo relax che riduce lo stress e rigenera il corpo. Il calore favorisce la sudorazione, stimola la circolazione, rilassa i muscoli e contribuisce al benessere generale.
 / **The benefits of dry sauna** - A deeply relaxing experience that reduces stress and rejuvenates the body. Heat promotes sweating, stimulates circulation, relaxes muscles, and contributes to overall well-being
 / **Les bienfaits du sauna sec** - Une expérience de relaxation profonde qui réduit le stress et régénère le corps. La chaleur favorise la transpiration, stimule la circulation, détend les muscles et contribue au bien-être général / **Los beneficios de la sauna seca** - Una experiencia de profunda relajación que reduce el estrés y regenera el cuerpo. El calor favorece la sudoración, estimula la circulación, relaja los músculos y contribuye al bienestar general / **Die Vorteile der Trockensauna** - Ein tief entspannendes Erlebnis, das Stress reduziert und den Körper regeneriert. Die Wärme fördert das Schwitzen, regt die Durchblutung an, entspannt die Muskulatur und trägt zum allgemeinen Wohlbefinden bei.



Stufa ad incasso

Massimo spazio al comfort ed al design interno della sauna, grazie alla stufa incassata e nascosta sotto la panca relax.
 / **Built-in heater** - Maximum space for comfort and sauna interior design, thanks to the heater built in and concealed under the relaxation bench / **Poêle encastré** - Un maximum d'espace dédié au confort et au design intérieur du sauna, grâce au poêle encastré et dissimulé sous la banquette de relaxation / **Estufa empotrada** - Máximo espacio para el confort y el diseño interior de la sauna, gracias a la estufa empotrada y oculta bajo el banco de relax / **Einbauofen** - Maximaler Raum für Komfort und Saunainnenraumgestaltung dank des eingebauten und unter der Relaxliege verborgenen Ofens.



Display digitale Oled

Pulito ed essenziale il display digitale esterno, dall'elegante interfaccia intuitiva, consente il controllo di tutte le funzioni della sauna
 / **OLED digital display** - Clean and essential, the external digital display with an elegant and intuitive interface allows control of all sauna functions
Afficheur numérique OLED - Épuré et essentiel, l'afficheur numérique extérieur à l'interface élégante et intuitive permet de contrôler toutes les fonctions du sauna / **Pantalla digital OLED** - Limpia y esencial, la pantalla digital externa con una interfaz elegante e intuitiva permite el control de todas las funciones de la sauna / **OLED-Digitaldisplay** - Klar und reduziert gestaltet, ermöglicht das externe Digitaldisplay mit eleganter und intuitiver Benutzeroberfläche die Steuerung aller Saunafunktionen.





I benefici dell'Hammmam

Il vapore avvolgente favorisce una profonda detossinazione della pelle e un'intensa sensazione di benessere. Il calore umido stimola la circolazione, rilassa i muscoli e accompagna corpo e mente in un rilassamento profondo

/ The benefits of the Hammam - Enveloping steam promotes deep skin detoxification and an intense sense of well-being. Moist heat stimulates circulation, relaxes muscles, and guides body and mind into deep relaxation

/ Les bienfaits du hammam - La vapeur enveloppante favorise une détoxification profonde de la peau et une intense sensation de bien-être. La chaleur humide stimule la circulation, détend les muscles et accompagne le corps et l'esprit vers une relaxation profonde

/ Los beneficios del hammam - El vapor envolvente favorece una profunda desintoxicación de la piel y una intensa sensación de bienestar. El calor húmedo estimula la circulación, relaja los músculos y acompaña cuerpo y mente hacia una relajación profunda

/ Die Vorteile des Hammams - Der umhüllende Dampf fördert eine tiefgehende Entgiftung der Haut und ein intensives Wohlbefinden. Die feuchte Wärme regt die Durchblutung an, entspannt die Muskulatur und führt Körper und Geist in tiefe Entspannung.



Generatore di vapore

Esclusiva Albatros che unisce funzionalità e design. Installazione ad incasso con Cover Plus a vista, disponibile in 4 finiture, per un'integrazione elegante e discreta nell'ambiente.

/ Steam generator - Albatros exclusive that combines functionality and design. Built-in installation with visible Cover Plus, available in 4 finishes, for elegant and discreet integration into the environment

/ Générateur de vapeur - Exclusivité Albatros alliant fonctionnalité et design. Installation encastrée avec Cover Plus apparent, disponible en 4 finitions, pour une intégration élégante et discrète dans l'espace

/ Generator de vapor - Exclusiva Albatros que combina funcionalidad y diseño. Instalación empotrada con Cover Plus a la vista, disponible en 4 acabados, para una integración elegante y discreta en el ambiente

/ Dampfgenerator - Exklusives Albatros-Produkt, das Funktionalität und Design vereint. Einbauinstallation mit sichtbarem Cover Plus, erhältlich in 4 Oberflächen, für eine elegante und dezente Integration in den Raum.



Cover Plus con comandi integrati

Parte a vista del generatore di vapore, coordinabile con la finitura dell'hammam. Completabile con mensola e ganci porta accappatoio.

/ Cover Plus with integrated controls - Visible part of the steam generator, coordinated with the hammam finish. Can be completed with shelf and bathrobe hooks

/ Cover Plus avec commandes intégrées - Partie visible du générateur de vapeur, coordonnable avec la finition du hammam. Peut être complétée par une tablette et des crochets porte-peignoir

/ Cover Plus con mandos integrados - Parte visible del generador de vapor, coordinable con el acabado del hammam. Puede completarse con estante y ganchos porta albornoces

/ Cover Plus mit integrierten Bedienelementen - Sichtbarer Teil des Dampfgenerators, abgestimmt auf die Oberfläche des Hammams. Ergänzzbar mit Ablage und Bademantelhaken.



Funzioni Minipiscine

/ SPAS functions / Fonctions des mini-piscines

/ Funciones de las minipiscinas / Funktionen der Minipools



Whirlpool

Le minipiscine Albatros sono dotate di funzione Airpool (idromassaggio ad aria) e Whirlpool (idromassaggio ad acqua/aria).

L'esclusivo Albatros SPA System, di tipo Whirlpool, agisce attraverso la reimmissione dell'acqua, miscelata all'aria, nella vasca.

/ Albatros mini pools are equipped with the Airpool function (air hydromassage) and Whirlpool function (water/air hydromassage). The exclusive Albatros SPA System, of the Whirlpool type, operates by reintroducing water mixed with air into the tub. / Les mini-piscines Albatros sont équipées de la fonction Airpool (hydromassage à air) et de la fonction Whirlpool (hydromassage eau/air). L'exclusif Albatros SPA System, de type Whirlpool, agit par la réinjection de l'eau, mélangée à l'air, dans la cuve. / Las minipiscinas Albatros están equipadas con la función Airpool (hidromasaje de aire) y Whirlpool (hidromasaje de agua/aire). El exclusivo Albatros SPA System, de tipo Whirlpool, actúa mediante la reintroducción del agua, mezclada con aire, en la bañera. / Die Albatros Minipools sind mit der Airpool-Funktion (Luftmassage) und der Whirlpool-Funktion (Wasser-/Luftmassage) ausgestattet. Das exklusive Albatros SPA System vom Typ Whirlpool wirkt durch die Wiedereinleitung von mit Luft vermishtem Wasser in die Wanne.

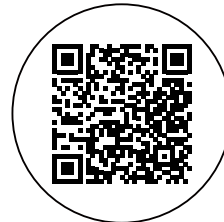

Scopri i nostri sistemi di idromassaggio

/ Discover our hydromassage systems

/ Découvrez nos systèmes de hydromassage

/ Descubre nuestros sistemas de hidromasaje

/ Entdecken Sie unsere Hydromassage-Systeme



Airpool

Il sistema idromassaggio Airpool immette aria nell'acqua attraverso le apposite bocchette posizionate sul fondo della vasca. Sistema particolarmente silenzioso, rilassante e distensivo, genera un massaggio efficace per rilassare la muscolatura.

/ The Airpool hydromassage system injects air into the water through dedicated nozzles positioned on the bottom of the tub. A particularly quiet, relaxing, and soothing system, it provides an effective massage to relax the muscles. / Le système d'hydromassage Airpool insuffle de l'air dans l'eau à travers des buses spécifiques placées au fond de la cuve. Particulièrement silencieux, relaxant et apaisant, il génère un massage efficace pour détendre la musculature. / El sistema de hidromasaje Airpool introduce aire en el agua a través de boquillas específicas situadas en el fondo de la bañera. Un sistema especialmente silencioso, relajante y distensivo, que genera un masaje eficaz para relajar la musculatura. / Das Airpool-Hydromassagesystem führt Luft über spezielle Düsen, die am Wannenboden positioniert sind, in das Wasser ein. Besonders leise, entspannend und wohltuend, erzeugt es eine wirksame Massage zur Lockerung der Muskulatur.



Elite, Thea Pool, Soreha, Oniris, Privè 103, Privè 206, Privè 306, Privè 405, Privè R07



Micro Silk

Sistema di idroterapia con microbolle di ossigeno che rendono l'acqua lattiginosa e avvolgono il corpo. Favorisce l'ossigenazione della pelle, stimola la produzione naturale di collagene, supporta il sistema immunitario e contribuisce all'igiene dell'acqua.

Utilizzo consigliato: circa 20 minuti per una pelle più liscia e uniforme.

/ A hydrotherapy system with oxygen microbubbles that make the water milky and envelop the body. It promotes skin oxygenation, stimulates natural collagen production, supports the immune system, and contributes to water hygiene.

Recommended use: approximately 20 minutes for

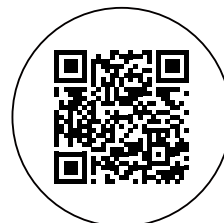

Scopri il funzionamento Microsilik®

/ Discover how Microsilik® works

/ Découvrez le fonctionnement de Microsilik®

/ Descubra el funcionamiento de Microsilik®

/ Entdecken Sie die Funktionsweise von Microsilik®

smoother, more even skin. / Système d'hydrothérapie à microbulles d'oxygène qui rendent l'eau lactescente et enveloppent le corps. Il favorise l'oxygénation de la peau, stimule la production naturelle de collagène, soutient le système immunitaire et contribue à l'hygiène de l'eau.

Utilisation recommandée : environ 20 minutes pour une peau plus lisse et plus uniforme. / Sistema de hidroterapia con microburbujas de oxígeno que vuelven el agua lechosa y envuelven el cuerpo. Favorece la oxigenación de la piel, estimula la producción natural de colágeno, apoya el sistema inmunitario y contribuye a la higiene del agua.

Usa recomendado: aproximadamente 20 minutos para una piel más lisa y uniforme. / Hydrotherapiesystem mit Sauerstoff-Mikrobläschen, die das Wasser milchig machen und den Körper umhüllen. Es fördert die Sauerstoffversorgung der Haut, regt die natürliche Kollagenproduktion an, unterstützt das Immunsystem und trägt zur Wasserhygiene bei.

Empfohlene Anwendung: etwa 20 Minuten für eine glattere und gleichmäßigere Haut.



Solid Surface

Materiale ecologico e riciclabile, colorato in massa. Vellutato al tatto, facile da pulire e mantenere, resistente e altamente igienico. Completamente ripristinabile e ideale per la massima libertà di design.

/ Eco-friendly and recyclable material, colored in the mass. Velvety to the touch, easy to clean and maintain, durable and highly hygienic. Fully restorable and ideal for maximum design freedom / Matériau écologique et recyclable, teinté dans la masse. Velouté au toucher, facile à nettoyer et à entretenir, résistant et hautement hygiénique. Entièrement restaurable et idéal pour une liberté de design maximale / Material ecológico y reciclable, coloreado en masa. Aterciopelado al tacto, fácil de limpiar y mantener, resistente y altamente higiénico. Completamente restaurable e ideal para la máxima libertad de diseño / Umweltfreundliches und recycelbares Material, durchgefärbt. Samtig in der Haptik, pflegeleicht, widerstandsfähig und äußerst hygienisch. Vollständig wiederherstellbar und ideal für maximale Gestaltungsfreiheit.

→ Syraka, Kellia, Modula



Filtro a cartuccia

Sistema di filtrazione con cartucce intercambiabili ad alta capacità filtrante, per trattenerne impurità e detriti. Garantisce acqua limpida con manutenzione semplice e rapida. Ideale per minipiscine, spa e piscine di piccole e medie dimensioni.

/ Filtration system with interchangeable cartridges featuring high filtering capacity, designed to retain impurities and debris.

Ensures clear water with simple and quick maintenance. Ideal for mini pools, spas, and small to medium-sized pools / Système de filtration avec cartouches interchangeables à haute capacité filtrante, conçu pour retenir les impuretés et les débris.

Garantit une eau limpide avec un entretien simple et rapide. Idéal pour les mini-piscines, les spas et les piscines de petites et moyennes dimensions / Sistema de filtración con cartuchos intercambiables de alta capacidad filtrante, para retener impurezas y residuos. Garantiza agua limpia con un mantenimiento sencillo y rápido. Ideal para minipiscinas, spas y piscinas de pequeño y mediano tamaño / Filtersystem mit austauschbaren Kartuschen mit hoher Filterleistung zur Rückhaltung von Verunreinigungen und Schmutzpartikeln.

Sorgt für klares Wasser bei einfacher und schneller Wartung. Ideal für Minipools, Spas sowie kleine und

→ Elite, Thea Pool, Soreha, Soreha Mini, Oniris, Miris, Aster, Privè 103, Privè 206, Privè 306, Privè 405, Privè R07, Kristal L, Kristal XL, Harry Swim 1-2-3

mittelgroße Pool

**Filtro a sabbia**

Sistema di filtrazione professionale con sabbia silicea o materiale filtrante equivalente per trattenere impurità e detriti. Indicato per piscine e minipiscine di grandi dimensioni o ad uso intensivo, gestisce elevate portate con cicli di filtrazione prolungati. Compatibile con pompe professionali e trattamenti di igienizzazione

/ Sand filter Professional filtration system using silica sand or equivalent filter media to retain impurities and debris. Suitable for large pools and mini pools or for intensive use, it handles high flow rates with extended filtration cycles. Compatible with professional pumps and water sanitization treatments / Filtre à sable Système de filtration professionnel avec sable siliceux ou matériau filtrant équivalent pour retenir les impuretés et les débris. Indiqué pour les piscines et mini-piscines de grandes dimensions ou à usage intensif, il gère des débits élevés avec des cycles de filtration prolongés. Compatible avec des pompes professionnelles et des traitements de désinfection

Filtro de arena

Sistema de filtración profesional con arena silicea o material filtrante equivalente para retener impurezas y residuos. Indicado para piscinas y minipiscinas de grandes dimensiones o de uso intensivo, gestiona altos caudales con ciclos de filtración prolongados. Compatible con bombas profesionales y tratamientos de higienización / Sandfilter

Professionelles Filtersystem mit Quarzsand oder gleichwertigem Filtermaterial zur Rückhaltung von Verunreinigungen und Schmutzpartikeln. Geeignet für große Pools und Minipools oder für intensive Nutzung, bewältigt es hohe Durchflussmengen mit verlängerten Filterzyklen. Kompatibel mit professionellen Pumpen und Wasseraufbereitungssystemen

→ **Default: Beverly, Forever**
Optional: Elite, Thea Pool, Soreha, Soreha Mini, Oniris, Miris, Privè 103, Privè 206, Privè 306, Privè 405, Privè R07, Kristal L, Kristal XL

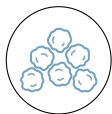
**Filtro a cotone**

Sistema di filtrazione con elementi in fibra di cotone per trattenere impurità e particelle fini. Lavabile, riutilizzabile e di facile manutenzione dell'acqua

/ Cotton filter - Filtration system with cotton fiber elements designed to retain impurities and fine particles. Washable, reusable, and easy to maintain / Filtre en coton

Système de filtration avec éléments en fibre de coton pour retenir les impuretés et les particules fines. Lavable, réutilisable et facile à entretenir / Filtro de algodón

- Sistema de filtración con elementos de fibra de algodón para retener impurezas y partículas finas. Lavable, reutilizable y de fácil mantenimiento

/ Baumwollfilter - Filtersystem mit Baumwollfaserelementen zur Rückhaltung von Verunreinigungen e feiner Partikel. Waschbar, wiederverwendbar und wartungsfreundlich.

→ **Syraka, Kellia, Marvelia, Aster**

**Pompe**

Dispositivi per il ricircolo continuo dell'acqua attraverso i sistemi di filtrazione e trattamento. Garantiscono portate adeguate, affidabilità e consumi ottimizzati, assicurando una distribuzione uniforme e una qualità dell'acqua costante.

/ Pumps - Devices for the continuous recirculation of water through filtration and treatment systems. They ensure adequate flow rates, reliability, and optimized energy consumption, providing uniform distribution and consistent water quality / Pompes -

→ **Kellia, Syraka, Modula, Elite, Thea Pool, Soreha, Soreha Mini, Oniris, Miris, Marvelia, Aster, Privè 103, Privè 206, Privè 306, Privè 405, Privè R07, Beverly, Forever, Kristal L, Kristal XL, Harry Swim 1-2-3**

*Dispositifs destinés à la recirculation continue de l'eau à travers les systèmes de filtration et de traitement. Elles garantissent des débits adaptés, une grande fiabilité et une consommation optimisée, assurant une distribution uniforme et une qualité d'eau constante / **Bombas** - Dispositivos para la recirculación continua del agua a través de los sistemas de filtración y tratamiento. Garantizan caudales adecuados, fiabilidad y consumos optimizados, asegurando una distribución uniforme y una calidad del agua constante / **Pumpen** - Geräte für die kontinuierliche Umwälzung des Wassers durch Filter- und Aufbereitungssysteme. Sie gewährleisten ausreichende Fördermengen, Zuverlässigkeit und optimierten Energieverbrauch und sorgen für eine gleichmäßige Verteilung sowie eine konstant hohe Wasserqualität.*

Silence SPA

Sistema esclusivo Albatros per il riscaldamento e il ricircolo dell'acqua con pompa a inverter.
Riduce i consumi e i costi di gestione, garantendo un funzionamento estremamente silenzioso per un relax totale
/ Exclusive Albatros system for water heating and recirculation with inverter pump. It reduces energy consumption and operating costs, ensuring extremely quiet operation for total relaxation / Système exclusif Albatros pour le chauffage et la recirculation de l'eau avec pompe à inverter. Il réduit la consommation et les coûts de gestion, garantissant un fonctionnement extrêmement silencieux pour une détente totale / Sistema esclusivo Albatros para el calentamiento y la recirculación del agua con bomba inverter. Reduce el consumo y los costes de funcionamiento, garantizando un funcionamiento extremadamente silencioso para una relajación total / Exklusives Albatros-System zur Wassererwärmung und -umwälzung mit Inverterpumpe. Es reduziert den Energieverbrauch und die Betriebskosten und gewährleistet einen äußerst leisen Betrieb für vollständige Entspannung.



Riscaldatore

Sistema di riscaldamento dell'acqua che consente di mantenere la temperatura desiderata in modo costante. Assicura comfort e continuità di utilizzo, con funzionamento affidabile ed efficiente.
/ Heater - Water heating system that allows the desired temperature to be maintained consistently. Ensures comfort and continuity of use, with reliable and efficient operation / Réchauffeur - Système de chauffage de l'eau permettant de maintenir de manière constante la température souhaitée. Assure confort et continuité d'utilisation, avec un fonctionnement fiable et efficace / Calentador - Sistema de calentamiento del agua que permite mantener de forma constante la temperatura deseada. Garantiza confort y continuidad de uso, con un funcionamiento fiable y eficiente / Heizer - Wasserheizsystem, das es ermöglicht, die gewünschte Temperatur konstant zu halten. Sorgt für Komfort und Nutzungskontinuität bei zuverlässigem und effizientem Betrieb

→ Kellia, Syraka, Modula, Elite, Thea Pool, Soreha, Soreha Mini, Oniris, Miris, Marvelia, Aster, Privè 103, Privè 206, Privè 306, Privè 405, Privè R07, Beverly, Forever, Kristal L, Kristal XL, Harry Swim 1-2-3



Pompa di calore - Hot & Ice

Sistema ad alta efficienza per il riscaldamento e il raffreddamento dell'acqua, che utilizza l'energia dell'aria per ridurre i consumi. Consente immersioni a diverse temperature, favorendo comfort prolungato, rigenerazione fisica e benessere dopo attività sportiva o sauna, con una

→ Optional

gestione energetica ottimizzata.

/ **Hot & Ice heat pump** - High-efficiency system for heating and cooling water, using air energy to reduce consumption. Allows immersion at different temperatures, promoting prolonged comfort, physical recovery, and well-being after sports activities or sauna, with optimized energy management

/ **Pompe à chaleur Hot & Ice** - Système à haute efficacité pour le chauffage et le refroidissement de l'eau, utilisant l'énergie de l'air pour réduire la consommation. Permet des immersions à différentes températures, favorisant un confort prolongé, la régénération physique et le bien-être après une activité sportive ou le sauna, avec une gestion énergétique optimisée / **Bomba de calor Hot & Ice** - Sistema de alta eficiencia para el calentamiento y el enfriamiento del agua, que utiliza la energía del aire para reducir el consumo. Permite inmersiones a diferentes temperaturas, favoreciendo el confort prolongado, la recuperación física y el bienestar tras la actividad deportiva o la sauna, con una gestión energética optimizada / **Hot & Ice Wärmepumpe** - Hocheffizientes System zum Heizen und Kühlen des Wassers, das die Energie der Umgebungsluft nutzt, um den Energieverbrauch zu reduzieren.

Ermöglicht Tauchgänge bei unterschiedlichen Temperaturen, fördert langanhaltenden Komfort, körperliche Regeneration und Wohlbefinden nach sportlicher Aktivität oder Saunagang bei optimierter Energieverwaltung

→ **Optional**



Scambiatore di calore

Sistema di riscaldamento che utilizza una fonte termica esterna per portare l'acqua alla temperatura desiderata.

Consente un riscaldamento efficiente e costante, integrabile con impianti esistenti.

/ **Heat exchanger** - Heating system that uses an external heat source to bring the water to the desired temperature. Allows efficient and consistent heating and can be integrated with existing systems

/ **Échangeur de chaleur** - Système de chauffage utilisant une source thermique externe pour porter l'eau à la température souhaitée. Permet un chauffage efficace et constant, intégrable aux installations existantes / **Intercambiador de calor** - Sistema de calentamiento que utiliza una fuente térmica externa para llevar el agua a la temperatura deseada.

Permite un calentamiento eficiente y constante, integrable con instalaciones existentes

/ **Wärmetauscher** - Heizsystem, das eine externe Wärmequelle nutzt, um das Wasser auf die gewünschte Temperatur zu bringen. Ermöglicht eine effiziente und konstante Erwärmung und lässt sich in bestehende Anlagen integrieren.

→ **Optional**



Clean Water

Sistema di disinfezione dell'acqua tramite tecnologia UV. La luce ultravioletta riduce la presenza di batteri e microrganismi, contribuendo a mantenere l'acqua più pura e piacevole.

/ **Water disinfection system using UV technology.** Ultraviolet light reduces the presence of bacteria and microorganisms, helping to keep the water purer and more pleasant / **Système de désinfection de l'eau par technologie UV.** La lumière ultraviolette réduit la présence de bactéries et de micro-organismes, contribuant à maintenir une eau plus pure et plus agréable / **Sistema de desinfección del agua mediante tecnología UV.** La luz ultravioleta reduce la presencia de bacterias y microorganismos, ayudando a mantener el agua más pura y agradable / **Wasserdeseinfektionssystem mit UV-Technologie.**

Ultraviolettes Licht reduziert Bakterien und Mikroorganismen und trägt dazu bei, das Wasser reiner und angenehmer zu halten.

→ **Kellia, Modula, Elite, Thea Pool, Soreha, Soreha Mini, Oniris, Miris, Marvelia, Privè 103, Privè 206, Privè 306, Privè 405, Privè R07, Beverly, Forever, Kristal L, Kristal XL, Harry Swim 1-2-3**



Sensore di livello acqua

Sistema di controllo che monitora il livello dell'acqua, contribuendo al corretto funzionamento e alla sicurezza dell'impianto.

/ **Water level sensor** - Control system that monitors the water level, contributing to proper operation and system safety / **Capteur de niveau d'eau** - Système de contrôle qui surveille le niveau de l'eau, contribuant au bon fonctionnement et à la sécurité de l'installation / **Sensor de nivel de agua** - Sistema de control que supervisa el nivel del agua, contribuyendo al correcto funcionamiento y a la seguridad del sistema / **Wasserstandssensor** - Kontrollsystem zur Überwachung des Wasserstands, das zum korrekten Betrieb und zur Sicherheit der Anlage beiträgt

→ Modula



Scarico e carico semi-automatico

Sistema che facilita le operazioni di svuotamento e riempimento della vasca.
/ **Semi-automatic drain and filling system** - System that facilitates tub draining and filling operations
/ **Système de vidage et de remplissage semi-automatique** - Système qui facilite les opérations de vidage et de remplissage de la cuve.
/ **Sistema de vaciado y llenado semiautomático** - Sistema que facilita las operaciones de vaciado y llenado de la bañera
/ **Halbautomatisches Entleerungs- und Befüllsystem** - System, das die Entleerungs- und Befüllvorgänge der Wanne erleichtert.



Refill

Sistema di reintegro automatico dell'acqua che mantiene il livello corretto all'interno della vasca.
/ **Automatic water refill system** that maintains the correct water level inside the tub
/ **Système de remplissage automatique de l'eau** qui maintient le niveau correct à l'intérieur de la cuve
/ **Sistema de relleno automático del agua** que mantiene el nivel correcto dentro de la bañera
/ **Automatisches Wassernachfüllsystem**, das den korrekten Wasserstand in der Wanne aufrechterhält.

→ Optional



Skimmer a parete

Sistema di raccolta dell'acqua in superficie che convoglia impurità e detriti verso il sistema di filtrazione.

/ **Surface water collection system** that channels impurities and debris towards the filtration system.
/ **Système de collecte de l'eau en surface** qui achemine les impuretés et les débris vers le système de filtration.
/ **Sistema de recogida del agua en superficie** que conduce impurezas y residuos hacia el sistema de filtración.
/ **Oberflächen-Wassersammelsystem**, das Verunreinigungen und Ablagerungen zum Filtersystem leitet.

→ Elite, Thea Pool, Soreha Pool, Soreha Mini



Skimmer flottante

Sistema di sfioro che favorisce una raccolta continua delle impurità superficiali, contribuendo a un aspetto dell'acqua più uniforme.

/ Overflow system that promotes continuous collection of surface impurities, contributing to a more uniform water appearance / Système à débordement favorisant la collecte continue des impuretés de surface, contribuant à un aspect de l'eau plus uniforme / Sistema de desbordamiento que favorece la recogida continua de impurezas superficiales, contribuyendo a un aspecto del agua más uniforme / Überlaufsystem, das die kontinuierliche Aufnahme von Oberflächenverunreinigungen fördert und zu einem gleichmäßigeren Erscheinungsbild des Wassers beiträgt.

→ Privè 103, Privè 206, Privè 306, Privè 405, Privè R07, Harry Swim 1-2-3



FilJet

Bocchette idromassaggio dal profilo ridotto, integrate nel design della vasca.

Garantiscono un getto uniforme e avvolgente, unendo comfort di massaggio ed eleganza estetica

/ Hydromassage jets with a reduced-profile design, integrated into the tub structure. They ensure a uniform, enveloping jet, combining massage comfort with refined aesthetics / Buses d'hydromassage au profil réduit, intégrées au design de la cuve. Elles garantissent un jet uniforme et enveloppant, alliant confort de massage et élégance esthétique / Boquillas de hidromasaje de perfil reducido, integradas en el diseño de la bañera. Garantizan un chorro uniforme y envolvente, combinando confort de masaje y elegancia estética / Hydromassagedüsen mit reduziertem Profil, in das Design der Wanne integriert. Sie gewährleisten einen gleichmäßigen, umhüllenden Wasserstrahl und vereinen Massagekomfort mit ästhetischer Eleganz.

→ Elite, Thea Pool, Soreha, Soreha Mini, Oniris, Miris, Marvelia, Aster, Kristal L, Kristal XL



Jet Pool

Bocchette idromassaggio con getto d'acqua direzionato e regolabile, progettate per offrire un massaggio mirato e personalizzabile sulle diverse zone del corpo.

/ Hydromassage jets with directed and adjustable water flow, designed to provide targeted and customizable massage on different areas of the body / Buses d'hydromassage avec jet d'eau directionnel et réglable, conçues pour offrir un massage ciblé et personnalisable sur différentes zones du corps / Boquillas de hidromasaje con chorro de agua direccionado y regulable, diseñadas para ofrecer un masaje específico y personalizable en distintas zonas del cuerpo / Hydromassagedüsen mit gerichtetem und einstellbarem Wasserstrahl, entwickelt für eine gezielte und individuell anpassbare Massage verschiedener Körperbereiche.

→ Privè 103, Privè 206, Privè 306, Privè 405, Privè R07, Beverly, Forever, Harry Swim 1-2-3

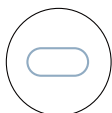

SecretJets

Sistema di idromassaggio integrato e non visibile, che diffonde l'azione dell'acqua senza bocchette a vista, per un'esperienza essenziale e un'estetica pulita.

/ Integrated and invisible hydromassage system that diffuses the water action without visible jets, for a minimalist experience and a clean aesthetic / Système d'hydromassage intégré et invisible, diffusant l'action de l'eau sans buses apparentes, pour une expérience essentielle et une esthétique épurée / Sistema de hidromasaje integrado e invisible que difunde la

→ Kellia, Modula, Syraka

acción del agua sin boquillas visibles, para una experiencia esencial y una estética limpia / Integriertes und unsichtbares Hydromassagesystem, das die Wasserwirkung ohne sichtbare Düsen verteilt – für ein reduziertes Erlebnis und eine klare Ästhetik.



RGB

Sistema di illuminazione che utilizza variazioni di colore per creare atmosfere rilassanti e personalizzabili.

/ Lighting system that uses color variations to create relaxing and customizable atmospheres / Système d'éclairage utilisant des variations de couleur pour créer des ambiances relaxantes et personnalisables / Sistema de iluminación que utiliza variaciones de color para crear ambientes relajantes y personalizables / Beleuchtungssystem, das Farbvariationen nutzt, um entspannende und individuell anpassbare Atmosphären zu schaffen.

→ Kellia, Modula, Syraka, Elite, Thea Pool, Soreha, Soreha Mini, Oniris, Miris, Marvelia, Aster, Privè 103, Privè 206, Privè 306, Privè 405, Privè R07, Beverly, Forever, Kristal L, Kristal XL, Harry Swim 1-2-3



Luce LED perimetrale

Illuminazione integrata lungo il perimetro della vasca per valorizzarne il profilo e creare un effetto scenografico.

/ Perimeter LED light - Integrated lighting along the tub perimeter to enhance its profile and create a striking visual effect / Éclairage LED périmétral - Éclairage intégré le long du périmètre de la cuve pour valoriser son profil et créer un effet scénographique / Luz LED perimetral - Iluminación integrada a lo largo del perímetro de la bañera para realzar su perfil y crear un efecto escenográfico / Perimetrale LED-Beleuchtung Integrierte Beleuchtung entlang des Wannensrandes zur Hervorhebung des Profils und zur Erzeugung eines eindrucksvollen Effekts.

→ Kristal L, Modula



Touch Display

Pannello di controllo touch per la gestione semplice e immediata delle funzioni della minipiscina.

/ Touch control panel for simple and immediate management of the mini pool functions / Panneau de commande tactile pour une gestion simple et immédiate des fonctions de la mini-piscine / Panel de control táctil para la gestión sencilla e inmediata de las funciones de la minipiscina / Touch-Bedienfeld für die einfache und unmittelbare Steuerung der Funktionen der Minipool.

→ Kellia, Modula, Syraka, Elite, Thea Pool, Soreha, Soreha Mini, Oniris, Miris, Marvelia, Aster, Privè 103, Privè 206, Privè 306, Privè 405, Privè R07, Kristal L, Kristal XL, Harry Swim 1-2-3



Pulsanti piezoelettrici

Comandi integrati sulla minipiscina per l'utilizzo e l'accensione del sistema idromassaggio.

/ Piezoelectric buttons - Integrated controls on the mini pool for operating and activating the hydromassage system / Boutons piézoélectriques - Commandes intégrées sur la mini-piscine pour l'utilisation et l'activation du système d'hydromassage / Botones piezoeléctricos - Mandos integrados en la minipiscina para el uso y la activación del sistema de hidromasaje / Piezoelektrische Tasten - Integrierte Bedienelemente an der Minipool zur Nutzung und Aktivierung des Hydromassagesystems.

→ Beverly, Forever



Pannelli B-Plus

Pannelli di rivestimento esterno progettati per valorizzare l'estetica della minipiscina e integrarla nell'ambiente outdoor.

→ Optional: Elite, Thea Pool, Soreha, Soreha Mini, Oniris, Miris, Marvelia, Aster, Privè 103, Privè 206, Privè 306, Privè 405, Privè R07, Kristal L, Kristal XL



/ B-Plus panels - External cladding panels designed to enhance the aesthetics of the mini pool and integrate it into the outdoor environment / **Panneaux B-Plus** - *Panneaux de revêtement extérieur conçus pour valoriser l'esthétique de la mini-piscine et l'intégrer dans l'environnement extérieur* / **Paneles B-Plus** - *Paneles de revestimiento exterior diseñados para realzar la estética de la minipiscina e integrarla en el entorno exterior* / **B-Plus-Paneele** - *Außenverkleidungspaneele, die entwickelt wurden, um die Ästhetik des Minipools aufzuwerten und ihn in die Außenumgebung zu integrieren.*

→ **Optional: Elite, Thea Pool, Soreha, Soreha Mini, Oniris, Miris, Marvelia, Aster, Privè 103, Privè 206, Privè 306, Privè 405, Privè R07, Kristal L, Kristal XL**



System Clean

Sistema integrato di disinfezione con serbatoio dedicato per l'inserimento del liquido. L'attivazione automatica consente di mantenere l'acqua pulita e igienizzata in modo semplice e controllato.
/ Integrated disinfection system with dedicated tank for liquid dosing. Automatic activation keeps the water clean and sanitized in a simple and controlled way /
Système de désinfection intégré avec réservoir dédié pour l'insertion du liquide. L'activation automatique permet de maintenir l'eau propre et hygiénisée de manière simple et contrôlée /
Sistema de desinfección integrado con depósito dedicado para la introducción del líquido. La activación automática permite mantener el agua limpia e higienizada de forma sencilla y controlada /
Integriertes Desinfektionssystem mit separatem Behälter zur Dosierung der Flüssigkeit. Die automatische Aktivierung hält das Wasser auf einfache und kontrollierte Weise sauber und hygienisch

→ **Syraka Bath, Kellia Bath, Tarim Bath, Soreha Mini Bath, Aster Bath, Marvelia Bath, Miris Bath, Ethos 140, Ethos Round 180, Altea 167-177-178-188, Altea 160, Altea 125, Altea 150, Altea Round 160**



Linfodrenaggio

Funzione di massaggio delicato attivata con l'idromassaggio, che grazie alle bolle favorisce rilassamento e benessere.
/ Lymphatic drainage / Drainage lymphatique / Drenaje linfático / Lymphdrainage
Gentle massage function activated with hydromassage, which through air bubbles promotes relaxation and well-being /
Fonction de massage doux activée avec l'hydromassage, qui grâce aux bulles favorise la détente et le bien-être /
Función de masaje suave activada con el hidromasaje que, gracias a las burbujas, favorece la relajación y el bienestar /
Sanfte Massagefunktion, die mit der Hydromassage aktiviert wird und dank der Luftblasen Entspannung und Wohlbefinden fördert

→ **Syraka Bath, Kellia Bath, Tarim Bath, Soreha Mini Bath, Aster Bath, Marvelia Bath, Miris Bath, Ethos 140, Ethos Round 180, Altea 167-177-178-188, Altea 160, Altea 125, Altea 150, Altea Round 160**

Green Plus



Microban

Superfici trattate con tecnologia antimicrobica Microban® per la protezione da muffe e batteri. Rivestimento in acrilico facile da pulire, altamente igienico e resistente a urti, abrasioni e raggi UV.

/ Surfaces treated with Microban® antimicrobial technology to protect against mold and bacteria.

Easy-to-clean acrylic coating, highly hygienic and resistant to impacts, abrasion, and UV rays / Surfaces traitées avec la technologie antimicrobienne Microban® pour la protection contre les moisissures et les bactéries. Revêtement en acrylique facile à nettoyer, hautement hygiénique et résistant aux chocs, aux abrasions et aux rayons UV / Superficies tratadas con tecnología antimicrobiana Microban® para la protección contra moho y bacterias. Revestimiento acrílico fácil de limpiar, altamente higiénico y resistente a golpes, abrasiones y rayos UV / Oberflächen, die mit der antimikrobiellen Microban®-Technologie behandelt sind, zum Schutz vor Schimmel und Bakterien.

Pflegeleichte Acrylbeschichtung, hochhygienisch und beständig gegen Stöße, Abrieb und UV-Strahlen.

→ Elite, Thea Pool, Soreha, Soreha Mini, Aster, Marvelia, Oniris, Miris, Privè 103, Privè 206, Privè 306, Privè 405, Privè R07, Beverly, Forever, Kristal L, Kristal XL, Harry Swim 1-2-3



Silence SPA

Sistema esclusivo Albatros per il riscaldamento e il ricircolo dell'acqua con pompa a inverter. Riduce i consumi e i costi di gestione, garantendo un funzionamento estremamente silenzioso per un relax totale

/ Exclusive Albatros system for water heating and recirculation with inverter pump.

It reduces energy consumption and operating costs, ensuring extremely quiet operation for total relaxation

/ Système exclusif Albatros pour le chauffage et la recirculation de l'eau avec pompe à inverter.

Il réduit la consommation et les coûts de gestion, garantissant un fonctionnement extrêmement silencieux pour une détente totale / Sistema esclusivo Albatros para el calentamiento y la recirculación del agua con bomba inverter. Reduce el consumo y los costes de funcionamiento, garantizando un funcionamiento extremadamente silencioso para una relajación total

/ Exklusives Albatros-System zur Wassererwärmung und -umwälzung mit Inverterpumpe. Es reduziert den Energieverbrauch und die Betriebskosten und gewährleistet einen äußerst leisen Betrieb für vollständige Entspannung.

→ Kellia, Syraka, Modula, Elite, Thea Pool, Soreha, Soreha Mini, Oniris, Kristal L, Kristal XL



Eco-Material

Materiale in Solid Surface ecologico, resistente e altamente igienico.

Facile da pulire e completamente ripristinabile.

Eco-friendly Solid Surface material, durable and highly hygienic. Easy to clean and fully restorable / Matériau en Solid Surface écologique, résistant et hautement hygiénique. Facile à nettoyer et entièrement restaurable / Material en Solid Surface ecológico, resistente y altamente higiénico. Fácil de limpiar y completamente restaurable / Umweltfreundliches Solid-Surface-Material, widerstandsfähig und äußerst hygienisch. Leicht zu reinigen und vollständig wiederherstellbar

→ Syraka, Kellia, Modula



Command SPA

Controllo remoto delle funzioni principali della minipiscina.

/ Remote control of the main mini pool functions

/ Contrôle à distance des principales fonctions de la mini-piscine / Control remoto de las funciones principales de la minipiscina / Fernsteuerung der wichtigsten Funktionen der Minipool.

→ Optional: Elite, Thea Pool, Soreha, Soreha Mini, Oniris, Miris, Marvelia, Aster, Privè 103, Privè 206, Privè 306, Privè 405, Privè R07



Energy Saving Cover

Cover progettata per mantenere la temperatura dell'acqua e ridurre i consumi energetici. Materiale isolante, impermeabile e resistente ai raggi UV.

Mini pool cover designed to maintain water temperature and reduce energy consumption. Insulating, waterproof, and UV-resistant material

/ Couverture pour mini-piscine conçue pour maintenir la température de l'eau et réduire la consommation énergétique. Matériau isolant, imperméable et résistant aux rayons UV / Cubierta para minipiscina diseñada para mantener la temperatura del agua y reducir el consumo energético. Material aislante, impermeable y resistente a los rayos UV / Abdeckung für Minipools zur Aufrechterhaltung der Wassertemperatur und zur Reduzierung des Energieverbrauchs. Isolierendes, wasser- und UV-beständiges Material

→ Optional: Kellia, Modula, Syraka, Elite, Thea Pool, Soreha, Soreha Mini, Oniris, Miris, Marvelia, Aster, Privè 103, Privè 206, Privè 306, Privè 405, Privè R07, Kristal L, Kristal XL, Harry Swim 1-2-3

Cura e Manutezione

/ Care and maintenance / Entretien et maintenance
/ Cuidado y mantenimiento / Pflege und Wartung



Acrilico

Materiale compatto e non poroso, resistente all'usura, agli urti, alle abrasioni e ai raggi UV. Facile da pulire e progettato per preservare nel tempo l'estetica della vasca. Disponibile in bianco lucido e bianco opaco Edelweiss, con finitura vellutata al tatto.

Acrylic

Compact, non-porous material resistant to wear, impacts, abrasion, and UV rays. Easy to clean and designed to preserve the tub's aesthetics over time. Available in glossy white and Edelweiss matte white, with a velvety touch finish

Acrylique

Matériau compact et non poreux, résistant à l'usure, aux chocs, aux abrasions et aux rayons UV.

Facile à nettoyer et conçu pour préserver l'esthétique de la cuve dans le temps. Disponible en blanc brillant et blanc mat Edelweiss, avec une finition veloutée au toucher

Acrílico

Material compacto y no poroso, resistente al desgaste, a los golpes, a las abrasiones y a los rayos UV.

Fácil de limpiar y diseñado para preservar la estética de la bañera con el paso del tiempo. Disponible en blanco brillo y blanco mate Edelweiss, con acabado aterciopelado al tacto

Acryl

Kompaktes, nicht poröses Material, beständig gegen Abnutzung, Stöße, Abrieb und UV-Strahlen.

Pflegeleicht und darauf ausgelegt, die Ästhetik der Wanne langfristig zu bewahren. Erhältlich in glänzendem Weiß und mattem Edelweiss-Weiß, mit samtiger Haptik.

Manutenzione ordinaria e straordinaria

Rivestimento atossico e ipoallergico che garantisce un elevato livello di igiene. Facile da pulire e da mantenere nel tempo con semplici gesti e comuni prodotti per la pulizia domestica.

Ordinary and extraordinary maintenance

Non-toxic and hypoallergenic surface coating that ensures a high level of hygiene. Easy to clean and maintain over time with simple actions and common household cleaning products

Entretien courant et extraordinaire

Revêtement non toxique et hypoallergénique garantissant un niveau d'hygiène élevé. Facile à nettoyer et à entretenir dans le temps avec des gestes simples et des produits ménagers courants

Mantenimiento ordinario y extraordinario

Revestimiento no tóxico e hipoalergénico que garantiza un alto nivel de higiene. Fácil de limpiar y mantener a lo largo del tiempo con gestos sencillos y productos de limpieza domésticos comunes

Ordentliche und außerordentliche Wartung

Ungiftige und hypoallergene Beschichtung, die ein hohes Hygieneniveau gewährleistet.

Leicht zu reinigen und dauerhaft zu pflegen mit einfachen Handgriffen und handelsüblichen Haushaltsreinigern.



Solid Surface

Superficie solida Made in Italy composta da materiale minerale naturale e resina acrilica di alta qualità. Compatta, non porosa e stabile nel tempo, mantiene inalterato il colore senza ingiallire.

La colorazione in massa consente il completo ripristino della superficie e garantisce prestazioni costanti nel tempo.

/ Composed of natural mineral material and high-quality acrylic resin. Compact, non-porous, and stable over time, it maintains its original color without yellowing. The through-body coloration allows full surface restoration and ensures consistent performance over time.

/ Composée de matériau minéral naturel et de résine acrylique de haute qualité. Compacte, non poreuse et stable dans le temps, elle conserve sa couleur sans jaunir. La coloration dans la masse permet une restauration complète de la surface et garantit des performances constantes dans le temps / Compuesta por material mineral natural y resina acrílica de alta calidad. Compacta, no porosa y estable en el tiempo, mantiene el color inalterado sin amarillear. La coloración en masa permite la restauración completa de la superficie y garantiza prestaciones constantes a lo largo del tiempo / Aus natürlichem Mineralmaterial und hochwertigem Acrylharz. Kompakt, nicht porös und dauerhaft stabil, behält sie ihre Farbe bei, ohne zu vergilben. Die Durchfärbung ermöglicht eine vollständige Wiederherstellung der Oberfläche und gewährleistet gleichbleibende Leistung über die Zeit.

Manutenzione ordinaria e straordinaria

Superficie in Solid Surface compatta, non porosa e igienica, facile da pulire e durevole nel tempo. Per la pulizia ordinaria e il calcare utilizzare un detergente delicato, panno o spugna morbidi; risciacquare con acqua tiepida e asciugare. La colorazione in massa consente la rimozione di piccoli graffi o segni superficiali; per danni più profondi è possibile un intervento di ripristino da parte di personale specializzato. Evitare detergenti aggressivi, alcool, solventi, acetoni o prodotti non specifici.

Ordinary and extraordinary maintenance

Compact, non-porous, and hygienic Solid Surface, easy to clean and durable over time. For routine cleaning and limescale removal, use a mild detergent with a soft cloth or sponge; rinse with lukewarm water and dry. Through-body coloration allows the removal of small scratches or surface marks; for deeper damage, restoration by specialized personnel is possible. Avoid aggressive detergents, alcohol, solvents, acetone, or non-specific products /

Entretien courant et extraordinaire - Surface en Solid Surface compacte, non poreuse et hygiénique, facile à nettoyer et durable dans le temps. Pour le nettoyage courant et l'élimination du calcaire, utiliser un détergent doux avec un chiffon ou une éponge souple ; rincer à l'eau tiède et sécher. La coloration dans la masse permet l'élimination de petites rayures ou marques superficielles ; pour des dommages plus profonds, une intervention de restauration par du personnel spécialisé est possible. Éviter les détergents agressifs, l'alcool, les solvants, l'acétone ou les produits non spécifiques /

Mantenimiento ordinario y extraordinario - Superficie de Solid Surface compacta, no porosa e higiénica, fácil de limpiar y duradera en el tiempo. Para la limpieza ordinaria y la eliminación de la cal, utilizar un detergente suave con un paño o esponja blanda; aclarar con agua tibia y secar. La coloración en masa permite eliminar pequeños arañazos o marcas superficiales; para daños más profundos es posible una intervención de restauración por parte de personal especializado. Evitar detergentes agresivos, alcohol, disolventes, acetona o productos no específicos /

Ordentliche und außerordentliche Wartung - Kompakte, nicht poröse und hygienische Solid-Surface-Oberfläche, leicht zu reinigen und langlebig. Für die regelmäßige Reinigung und die Entfernung von Kalk einen milden Reiniger mit einem weichen Tuch oder Schwamm verwenden; mit lauwarmem Wasser abspülen e trocknen. Die Durchfärbung ermöglicht die Entfernung kleiner Kratzer oder oberflächlicher Spuren; bei tieferen Schäden ist eine Wiederherstellung durch Fachpersonal möglich. Aggressive Reinigungsmittel, Alkohol, Lösungsmittel, Aceton oder nicht geeignete Produkte vermeiden.

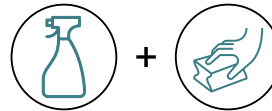
**TIPOLOGIA MACCHIA**

Stain Type / Type de tache / Tipo de mancha / Art der Verschmutzung

SOLID SURFACE

COFFEE	Pulire con spugna e Chanteclair <i>Clean with sponge and Chanteclair / Nettoyer avec une éponge et Chanteclair / Limpiar con esponja y Chanteclair / it Schwamm und Chanteclair reinigen</i>
FONDOTINTA <i>Foundation / Fond de teint / Base de maquillage / Make-up-Grundierung</i>	Pulire con spugna e Chanteclair <i>Clean with sponge and Chanteclair / Nettoyer avec une éponge et Chanteclair / Limpiar con esponja y Chanteclair / Mit Schwamm und Chanteclair reinigen</i>
MASCARA <i>Máscara de pestañas / Wimperntusche</i>	Pulire con spugna e Chanteclair <i>Clean with sponge and Chanteclair / Nettoyer avec une éponge et Chanteclair / Limpiar con esponja y Chanteclair / Mit Schwamm und Chanteclair reinigen</i>
MATITA PER OCCHI <i>Eyeliner / Crayon pour les yeux / Lápiz de ojos / Augentstift</i>	Pulire con spugna e Chanteclair <i>Clean with sponge and Chanteclair / Nettoyer avec une éponge et Chanteclair / Limpiar con esponja y Chanteclair / Mit Schwamm und Chanteclair reinigen</i>
ROSSETTO <i>Lipstick / Rouge à lèvres / Pintalabios / Lippenstift</i>	Pulire con spugna e Chanteclair <i>Clean with sponge and Chanteclair / Nettoyer avec une éponge et Chanteclair / Limpiar con esponja y Chanteclair / Mit Schwamm und Chanteclair reinigen</i>
SMALTO <i>Nail polish / Vernis à ongles / Esmalte de uñas / Nagellack</i>	Pulire con spugna e Solvente ① <i>Clean with sponge and Solvent / Nettoyer avec une éponge et un solvan / Limpiar con una esponja y disolvente / Mit Schwamm und Lösungsmittel reinigen</i>
SIGARETTE <i>Cigarette / Cigarrillos / Zigaretten</i>	Pulire con spugna e Cif <i>Clean with sponge and Cif / Nettoyer avec une éponge et Cif / Limpiar con una esponja y Cif / Mit Schwamm und Cif reinigen</i>
TINTA CAPELLI <i>Hair Dye / Coloration pour cheveux / Tinte para el cabello / Haarfarbe</i>	Pulire con spugna e Cif <i>Clean with sponge and Cif / Nettoyer avec une éponge et Cif / Limpiar con una esponja y Cif / Mit Schwamm und Cif reinigen</i>

① **Per le macchie resistenti utilizzare la parte abrasiva della spugna**
/ Use the abrasive part of the sponge for resistant stains / Pour les taches tenaces, utiliser la partie abrasive de l'éponge / Para las manchas persistentes, utilizar la parte abrasiva de la esponja / Bei hartnäckigen Flecken die scheuernde Seite des Schwamms verwenden.

② **Per ripristinare la lucentezza usare pasta abrasiva (tipo Arexon). Non utilizzare la spugna abrasiva**
/ Use abrasive paste to restore the gloss (ex. Arexon). Do not use an abrasive sponge / Pour restaurer la brillance, utiliser une pâte abrasive (type Arexon). Ne pas utiliser l'éponge abrasive / Para restaurar el brillo, utilizar una pasta abrasiva (tipo Arexon). No utilizar la esponja abrasiva / Para restaurar el brillo, utilizar una pasta abrasiva (tipo Arexon). No utilizar la esponja abrasiva / Zur Wiederherstellung des Glanzes eine Polierpaste (z. B. Arexon) verwenden. Den scheuernden Schwamm nicht verwenden.

NON USARE DIRETTAMENTE SULLA SUPERFICIE: SOLVENTI, SOSTANZE AGGRESSIVE O PRODOTTI DI CUI NON SI CONOSCE L'AGGRESSIVITÀ
/ Do not use directly on the surface: solvents, aggressive substances, or products whose aggressiveness is unknown / Ne pas utiliser directement sur la surface: solvants, substances agressives ou produits dont l'agressivité n'est pas connue / No utilizar directamente sobre la superficie: disolventes, sustancias agresivas o productos cuya agresividad se desconoce / Nicht direkt auf der Oberfläche verwenden: Lösungsmittel, aggressive Substanzen oder Produkte mit unbekannter Aggressivität

CONDIZIONI GENERALI DI VENDITA

1. Condizioni generali

1.1 Per tutti gli ordini fatti alla La Doccia S.r.l. valgono le seguenti condizioni contrattuali generali. Accordi diversi non sono vincolanti, salvo che questi non siano riconosciuti in forma scritta ed esplicita dalla La Doccia S.r.l.

1.2 Le condizioni sotto elencate si intendono accettate integralmente con il conferimento dell'ordine.

1.3 Le condizioni contrattuali generali valgono anche per tutti i futuri affari con la parte contraente ed hanno la prevalenza sugli usi commerciali nazionali ed internazionali.

2. Offerte e documentazioni

2.1 Le offerte devono essere formulate in forma scritta dalla La Doccia S.r.l. ed hanno validità di 1 mese dalla data di consegna di esecuzione salvo accordi diversi.

2.2 La La Doccia S.r.l. si riserva il diritto di esclusiva ed i diritti su tutta la documentazione relativa l'offerta. La documentazione non deve essere accessibile a terzi.

2.3 I prezzi delle singole voci di un'offerta hanno validità solo in concomitanza con la conferma d'ordine di tutte le voci indicate nell'offerta.

3. Ordini

3.1 Gli ordini sono accettati dalla La Doccia S.r.l. solo se inviati in forma scritta e completi in ogni loro parte.

3.2 Accordi verbali o telefonici diventano vincolanti solo quando sono riportati in forma scritta.

3.3 Nessun ordine può essere annullato senza il consenso della La Doccia S.r.l. che si riserva la facoltà di addebitare spese ed oneri che ne derivano.

3.4 Cambiamenti o annullamenti di ordini di materiale standard o speciale (misure speciali, serigrafie particolari, colorati) non sono accettati.

3.5 Gli ordini possono essere evasi dalla ditta La Doccia S.r.l. anche parzialmente.

4. Prezzi

4.1 Nel caso in cui non risulti diversamente dalla conferma d'ordine, i prezzi sono espressi in euro e si intendono IVA esclusa e franco fabbrica.

4.2 Il prezzo di ciascun prodotto include l'imballo. Imballi di legno o pallets che occorressero per garantire un maggiore margine di integrità della merce, saranno fatturati al costo.

4.3 Non sono pertanto comprese nel prezzo le spese e gli oneri accessori, come ad esempio: trasporto, tasse, montaggio, installazioni, ecc., che saranno a carico dell'acquirente.

4.4 I prezzi confermati nell'ordine dalla La Doccia S.r.l. si intendono vincolanti solo fino alla data di consegna concordata nella conferma d'ordine. Nel caso in cui i costi del materiale aumentino nel periodo tra la stipulazione del contratto ed il suo adempimento, la La Doccia S.r.l. si riserva in ogni caso il diritto di effettuare un'adeguata correzione dei prezzi.

5. Condizioni e tempi di consegna

5.1 I giorni lavorativi vengono computati a partire dalla conferma dell'ordine da parte di La Doccia S.r.l.

Nel conteggio dei giorni sopra indicati, non sono compresi quelle di chiusura per ferie aziendali (agosto) o pre festività (vacanze natalizie).

I termini fissati per la spedizione non sono tassativi e in nessun caso possono costituire pretesto per ritardi nei pagamenti o richieste di risarcimento danni. Gli ordini possono essere evasi anche parzialmente.

5.2 Per cause di forza maggiore la La Doccia S.r.l. può prolungare i tempi di esecuzione dell'ordine per il tempo necessario alla risoluzione dei fatti sopravvenuti. si intendono per cause di forza maggiore anche gli scioperi e le difficoltà imprevedibili nell'fornitura dei materiali così come una sospensione del lavoro.

5.3 Il rispetto dei tempi di consegna concordati presuppone la completezza dell'ordine stesso in ogni sua parte e l'adempimento degli impegni di pagamento da parte del committente.

5.4 Ai sensi dell'art. 1510 del Codice Civile, la merce viaggia a rischio e pericolo del committente anche nel caso in cui la spedizione avviene a carico della La Doccia S.r.l.

5.5 A consegna avvenuta la merce deve essere controllata immediatamente dall'acquirente. Consegne incomplete o danneggiate devono essere annotate immediatamente sul documento di trasporto e comunicate in forma scritta alla ditta La Doccia S.r.l. entro 8 giorni dall'accettazione della merce (art. 1698).

5.6 Ricambi e accessori urgenti verranno spediti con corriere veloce e con spedizione dedicata solo su espressa richiesta scritta da parte del cliente.

6. Condizioni di pagamento

6.1 In mancanza di accordi diversi il pagamento si intende anticipato, in particolare per ordini con importo inferiore a € 100,00 (IVA esclusa) la fatturazione avverrà in contrassegno o bonifico anticipato.

6.2 In caso di ritardo nel pagamento la ditta La Doccia S.r.l. non è vincolata ad eseguire altre consegne né relative all'ordine in oggetto, né per gli altri ordini.

6.3 Non si accettano cambiali e/o assegni.

6.4 A prescindere dalla condizioni di pagamento concordate la La Doccia S.r.l. può pretendere il saldo immediato del pagamento, ogni qual volta si venga a conoscenza di fatti che mettano in dubbio il credito del committente.

7. Garanzia

7.1 La La Doccia S.r.l. garantisce i propri prodotti per 24 mesi dalla data di acquisto, comprovata dalla ricevuta o scontrino fiscale o da altro documento che attesti l'effettiva data di acquisto. La garanzia è data, in Italia, nei limiti di cui al D.L. 2 Febbraio

2002, nr° 24 e negli altri Paesi CE, nei limiti delle norme emanate in esecuzione della direttiva 1999/44/CE.

7.2 La sopraccitata garanzia impegna la La Doccia S.r.l. solo alla riparazione e/o alla sostituzione degli elementi difettosi; sono escluse ulteriori pretese da parte del committente.

7.3 Non sono coperti da garanzia i danni provocati da utilizzo o montaggio improprio dei prodotti e danni provocati nel trasporto. Questi ultimi devono essere segnalati al trasportatore al momento della consegna.

7.4 Il diritto di garanzia deve essere esercitato entro il periodo di garanzia, presso il rivenditore da cui è stato acquistato il prodotto e solo se accompagnato da certificato di garanzia presente all'interno dell'imballo e da un documento di acquisto.

7.5 Ogni riparazione, cambiamento o alterazione di qualsiasi tipo apportata sui prodotti dal committente, dall'installatore o dall'utilizzatore, libera la La Doccia S.r.l. da ogni prestazione in garanzia. Nessuna riparazione a carico della La Doccia S.r.l. viene riconosciuta se non preventivamente autorizzata in forma scritta dalla La Doccia S.r.l. stessa.

7.6 Le responsabilità della La Doccia S.r.l. per danni derivanti da prodotti difettosi è regolata nei Paesi CE dalle normative nazionali emanate in esecuzione della direttiva CEE nr° 1999/34/CE.

8. Ritiro e riparazioni

8.1 In linea di massima non c'è possibilità di ritiro o restituzione. Eventuali eccezioni vengono trattate dalla La Doccia S.r.l. solo dopo aver ricevuto una richiesta scritta. Non è mai comunque possibile il ritiro di speciali, serigrafie o colori speciali.

8.2 La La Doccia S.r.l. non accetta alcun ritiro senza aver precedentemente confermato in forma scritta l'autorizzazione al reso della merce ed aver concordato l'importo da accreditare.

8.3 La La Doccia S.r.l. non accetta alcun ritiro senza aver precedentemente confermato in forma scritta l'autorizzazione al ritiro per riparazione della merce.

9. Riserva di proprietà

9.1 Fino al completo pagamento la merce rimane di proprietà della La Doccia S.r.l. (art. 1523 seg. CC).

10. Cataloghi, depliant, progetti e altro

10.1 Le foto presenti nel catalogo non devono essere considerate impegnative ed i dati su pesi e misure ivi contenute sono solo indicativi. Le cabine doccia vengono prodotte con materiali diversi come alluminio, cristallo, metacrilati e materiali sintetici. La ditta La Doccia S.r.l. si riserva il diritto di sostituire questi materiali con altri di pari o maggiore qualità e di effettuare cambiamenti se resi necessari dallo sviluppo tecnico.

10.2 La La Doccia S.r.l. declina ogni responsabilità per eventuali errori di stampa che non portano comunque costituire motivo di reclamo.

10.3 I pesi e n° dei colli presenti all'interno del listino sono approssimativi e non vincolanti soggetti a variazione

11. Sede esecutiva e foro competente

11.1 La sede esecutiva per ogni consegna e pagamento è a Padova, anche quando la consegna avviene in altro luogo.

11.2 Per tutti i contratti stipulati tra la La Doccia S.r.l. ed i suoi contraenti e per tutti i conseguenti diritti, viene applicato il diritto italiano.

11.3 Nel caso in cui una clausola delle condizioni contrattuali generali qui esposte dovesse essere nulla, questo non avrà effetti sui restanti accordi.

11.4 Come unico Foro competente per tutte le controversie derivanti da un contratto viene stabilito il Tribunale di Padova in accordo con art. 17 della Convenzione Bruxelles.

12. Tutela dei dati

12.1 Ai sensi degli art. 7 e 13 del D.Lgs. 30.06.2003 nr° 196, la La Doccia S.r.l. dichiara che i dati messi a disposizione dal committente verranno elaborati in rispetto della legge sulla tutela della privacy e precisamente solo per scopi relativi ad attuali o futuri negozi giuridici.

13. Costo di trasporto

Le spese di trasporto saranno addebitate come segue:

- Per ordini fino ad un valore netto di € 1.000,00, costo fisso minimo di € 80,00;

- Per ordini superiori a € 1.000,00 netti, verrà applicata una percentuale in base alla regione di destinazione.

N.B.: La Doccia S.r.l. declina ogni responsabilità per eventuali errori di stampa ivi contenuti.

GENERAL SALES CONDITIONS

1. General condition

1.1 The following general contractual conditions are valid for all the orders placed with La Doccia S.r.l. Any other agreements are not binding unless they have been expressly recognised in writing by La Doccia S.r.l.

1.2 The conditions below are deemed to be accepted when the order is placed.

1.3 This general contractual conditions are also valid for all future business with the contracting party and override any international or national trade usages.

2. Offers and documentation

2.1 Offers must be formulated in writing by La Doccia S.r.l. and are valid for 1 month from their date of execution unless otherwise agreed.

2.2 La Doccia S.r.l. reserves the right of exclusion and the rights to all the offer documentation. Documentation must not be made available to third-parties.

2.3 The prices of the individual items in an offer are valid only in conjunction with the order confirmation for all items stated in the offer.

3. Orders

3.1 Orders shall be accepted by La Doccia S.r.l. only if sent in writing and if each part is filled out.

3.2 Verbal or telephone agreements shall be binding only after they are stated in writing.

3.3 No order may be cancelled without the authorisation of La Doccia S.r.l., which reserves the right to charge for any expenses deriving thereof.

3.4 Amendments or cancellations of orders for standard or special materials (special sizes, particular silkscreening, coloured) are not accepted.

3.5 La Doccia S.r.l. may also execute partial orders.

4. Prices

4.1 Unless otherwise stated in the order confirmation, the prices are in euro, exclude VAT.

4.2 The price of each product includes the packaging. Wooden packaging or pallets that are required in order to ensure additional protection for the goods shall be added to the invoice.

4.3 Therefore the price does not include any expenses and additional costs, for example: shipment, taxes, assembly, installation, etc., which are at the purchaser's expense.

4.4 The price confirmed in the order by La Doccia S.r.l. shall be binding only until delivery date stated in the order confirmation. Should the costs of materials increase in the period from the contract being stipulated to its execution, La Doccia S.r.l. reserves the right to amend the prices accordingly.

5. Delivery conditions and times

5.1 Working days are calculated starting from the order confirmation issued by La Doccia S.r.l.

5.2 In the event of force majeure, La Doccia S.r.l. may delay the order execution for the time needed to resolve these circumstances. Force majeure includes strikes and any unforeseen difficulties in the supply of materials, such as adjournments.

5.3 The agreed delivery time shall be observed if each part of the order has been completed and the principle has fulfilled his payment obligations.

5.4 In accordance with art. 1510 of the Civil Code, the goods travel at the principle's risk even when they are shipped at the expense of La Doccia S.r.l..

5.5 On delivery, the goods shall be checked immediately by the purchaser. Any incomplete or damaged deliveries shall be written immediately on the shipment bill, and La Doccia S.r.l. shall be informed thereof in writing within 8 days of the goods being accepted (art. 1698).

6. Payment conditions

6.1 Payment shall be made in advance unless otherwise agreed.

6.2 If the payment is late, La Doccia S.r.l. is not bound to execute any other deliveries regarding the order in question or any other order.

6.3 Bill of exchange and/or cheques shall not be accepted.

6.4 Irrespective of the agreed payment conditions, La Doccia S.r.l. shall be paid immediately whenever there is evidence that the purchaser's credit is questionable.

7. Warranty

7.1 La Doccia S.r.l. guarantees its shower enclosures for 24 months for the date of delivery to the sales outlet; this does not include the glass parts. The warranty covers any parts that are faulty on account of defective manufacture and/or the replacement of faulty parts only; any additional claims made by the principle are not covered.

7.2 The aforementioned warranty binds La Doccia S.r.l. to the repair and/or the replacement of faulty parts only; any additional claims made by the principle are not covered.

7.3 The warranty does not cover damage caused by improper use or assembly of the product, or damage caused by shipment (contact the shipping agent for any such claims).

7.4 The right of warranty shall be exercised within the warranty period at the reseller from which the product was purchased and shall be valid only if accompanied by the certificate of warranty and by proof of purchase.

7.5 Repairs or modifications of any type made to the goods by the principle or by his employees frees La Doccia S.r.l. from all its warranty responsibilities. Any repairs at La Doccia S.r.l.'s expense shall not be recognised unless they have been authorised

in writing beforehand by La Doccia S.r.l..

7.6 La Doccia S.r.l.'s liability for damages on account of faulty products is governed in CE countries by national regulations that came into force with CE directive CEE n° 1999/34/CE.

8. Collection and repair

8.1 As a general rule, no goods shall be collected and returned. Any exceptions shall be dealt with by La Doccia S.r.l. only on receipt of a written request. Customized sizes, particular silk-screening or colours may not be returned.

8.2 La Doccia S.r.l. shall not collect any goods without first sending written authorisation that they are to be collected and agreeing the sum to be credited.

8.3 La Doccia S.r.l. shall not collect any goods without first sending written authorisation thereof.

9. Right of ownership

9.1 The goods shall remain the property of La Doccia S.r.l. until they been paid for completely (art. 1523 seg. CC).

10. Catalogues, leaflets, projects and the like

10.1 The photographs featured in the catalogues shall not be considered binding and the weights and sizes stated therein are for indication purposes only. The shower enclosures are produced with a variety of materials such as aluminum, plate glass, methacrylates, and synthetic materials. La Doccia S.r.l. reserves the right to replace these materials with others of equal or better quality, and to make any modifications in the name of technical improvement.

10.2 La Doccia S.r.l. shall not be liable for any printing errors, which in any case shall not constitute a reason for claims.

10.3 The weights and the number of packages in the list are approximate and non-binding subject to variation

11. Executive headquarters and competent court

11.1 The executive headquarters for each delivery and payment is Padua, even when the goods are delivered to another place.

11.2 Italian Law applies to all the contracts stipulated between La Doccia S.r.l. and its contracting parties, and to all consequent rights.

11.3 Should one clause of the contractual conditions herein be declared null and void, this shall have no effect on the rest of the agreement.

11.4 Padua Law Court shall be the sole competent court for any disputes arising from a contract in accordance with art. 17 of the Bruxelles Convention.

12. Privacy

12.1 Under and according to art. 7 and 13 of the legislative n° 196 of the 30.06.2003, La Doccia S.r.l. declares that any information placed at its disposal by the principle shall be processed in accordance with current privacy legislation, i.e. only for purposes regarding current or future juristic acts.

13 Transport costs

Transport costs will be charged as follows:

- For orders with a net value up to €1,000.00, a minimum fixed charge of €80.00 applies;

- For orders exceeding a net value of €1,000.00, a percentage charge will be applied based on the destination region.

N.B.: La Doccia S.r.l. shall not be liable for any printing errors herein.

CONDITIONS GÉNÉRALES

1. Conditions générales

1.1 Les présentes conditions contractuelles générales s'appliquent à toutes les commandes passées auprès de La Doccia S.r.l. Tout accord différent n'est pas contraignant, sauf s'il est expressément reconnu par écrit par La Doccia S.r.l.

1.2 Les conditions ci-dessous sont réputées acceptées intégralement dès la passation de la commande.

1.3 Les présentes conditions contractuelles générales s'appliquent également à toutes les relations commerciales futures avec la partie contractante et prévalent sur les usages commerciaux nationaux et internationaux.

2. Offres et documentation

2.1 Les offres doivent être formulées par écrit par La Doccia S.r.l. et sont valables pendant 1 mois à compter de la date d'émission, sauf accord contraire.

2.2 La Doccia S.r.l. se réserve les droits exclusifs et la propriété de toute la documentation relative à l'offre. Cette documentation ne doit pas être communiquée à des tiers.

2.3 Les prix des différentes positions d'une offre ne sont valables que si toutes les positions indiquées dans l'offre sont confirmées dans la commande.

3. Commandes

3.1 Les commandes sont acceptées par La Doccia S.r.l. uniquement si elles sont transmises par écrit et complètes dans toutes leurs parties.

3.2 Les accords verbaux ou téléphoniques ne deviennent contraignants que s'ils sont confirmés par écrit.

3.3 Aucune commande ne peut être annulée sans le consentement de La Doccia S.r.l., laquelle se réserve le droit de facturer les frais et charges qui en découlent.

3.4 Les modifications ou annulations de commandes de produits standard ou spéciaux (dimensions spéciales, sérigraphies particulières, couleurs spéciales) ne sont pas acceptées.

3.5 Les commandes peuvent être exécutées partiellement par La Doccia S.r.l.

4. Prix

4.1 Sauf indication contraire dans la confirmation de commande, les prix sont exprimés en euros, hors TVA, départ usine.

4.2 Le prix de chaque produit inclut l'emballage. Les emballages en bois ou palettes nécessaires pour garantir une meilleure protection de la marchandise seront facturés au prix coûtant.

4.3 Les frais et charges accessoires, tels que transport, taxes, montage, installation, etc., ne sont pas compris et restent à la charge de l'acheteur.

4.4 Les prix confirmés dans la commande sont contraignants uniquement jusqu'à la date de livraison convenue. En cas d'augmentation des coûts des matériaux entre la conclusion du contrat et son exécution, La Doccia S.r.l. se réserve le droit d'ajuster les prix.

5. Conditions et délais de livraison

5.1 Les jours ouvrables sont calculés à partir de la confirmation de commande. Les périodes de fermeture pour congés (août) et fêtes de fin d'année ne sont pas incluses. Les délais de livraison ne sont pas contraignants et ne peuvent en aucun cas justifier des retards de paiement ou des demandes d'indemnisation. Les livraisons partielles sont autorisées.

5.2 En cas de force majeure, y compris grèves, difficultés imprévisibles d'approvisionnement ou arrêt de travail, La Doccia S.r.l. peut prolonger les délais d'exécution.

5.3 Le respect des délais de livraison suppose que la commande soit complète et que le client respecte ses obligations de paiement.

5.4 Conformément à l'article 1510 du Code civil italien, la marchandise voyage aux risques et périls de l'acheteur, même si l'expédition est à la charge de La Doccia S.r.l.

5.5 À la livraison, la marchandise doit être contrôlée immédiatement. Toute livraison incomplète ou endommagée doit être signalée sur le document de transport et communiquée par écrit à La Doccia S.r.l. dans un délai de 8 jours.

5.6 Les pièces de rechange et accessoires urgents seront expédiés par transport express uniquement sur demande écrite du client.

6. Conditions de paiement

6.1 À défaut d'accord différent, le paiement est exigé à l'avance. Pour les commandes inférieures à 100,00 € HT, le paiement s'effectue par contre-remboursement ou virement anticipé.

6.2 En cas de retard de paiement, La Doccia S.r.l. n'est pas tenue d'effectuer d'autres livraisons, qu'elles concernent la commande en cours ou d'autres commandes.

6.3 Les traites et chèques ne sont pas acceptés.

6.4 Indépendamment des conditions de paiement convenues, La Doccia S.r.l. peut exiger le paiement immédiat si la solvabilité du client est mise en doute.

7. Garantie

7.1 La Doccia S.r.l. garantit ses produits pendant 24 mois à compter de la date d'achat, justifiée par un document valide. La garantie est fournie conformément au décret législatif italien n° 24/2002 et à la directive européenne 1999/44/CE.

7.2 La garantie couvre uniquement la réparation et/ou le remplacement des pièces défectueuses. Toute autre réclamation est exclue.

7.3 Les dommages dus à une utilisation, une installation incorrecte ou au transport

sont exclus de la garantie.

7.4 Le droit à la garantie doit être exercé auprès du revendeur et accompagné du certificat de garantie et d'un document d'achat.

7.5 Toute réparation, modification ou altération effectuée sans autorisation écrite dégage La Doccia S.r.l. de toute obligation de garantie.

7.6 La responsabilité pour dommages causés par des produits défectueux est régie par les lois nationales mettant en œuvre la directive 1999/34/CE.

8. Retours et réparations

8.1 En principe, aucun retour n'est accepté. Toute exception doit faire l'objet d'une demande écrite. Les produits spéciaux, sérigraphies et couleurs spéciales ne peuvent en aucun cas être retournés.

8.2 Aucun retour n'est accepté sans autorisation écrite préalable et accord sur le montant à créditer.

8.3 Aucun produit ne peut être retourné pour réparation sans autorisation écrite préalable.

9. Réserve de propriété

9.1 Les marchandises restent la propriété de La Doccia S.r.l. jusqu'au paiement intégral (art. 1523 du Code civil italien).

10. Catalogues, brochures, projets et autres documents

10.1 Les photos et données figurant dans les catalogues sont indicatives et non contractuelles. La Doccia S.r.l. se réserve le droit de remplacer les matériaux par d'autres de qualité égale ou supérieure et d'apporter des modifications techniques.

10.2 La Doccia S.r.l. décline toute responsabilité pour d'éventuelles erreurs d'impression.

10.3 Les poids et le nombre de colis sont approximatifs et non contraignants.

11. Lieu d'exécution et juridiction compétente

11.1 Le lieu d'exécution pour toute livraison et tout paiement est Padoue.

11.2 Le droit italien s'applique à tous les contrats.

11.3 La nullité éventuelle d'une clause n'affecte pas la validité des autres dispositions.

11.4 Le tribunal de Padoue est seul compétent pour tout litige.

12. Protection des données

12.1 Conformément aux articles 7 et 13 du décret législatif 196/2003, les données fournies seront traitées dans le respect de la législation sur la protection de la vie privée et uniquement à des fins commerciales.

13. Frais de transport

Les frais de transport seront facturés comme suit :

Commandes jusqu'à 1 000,00 € nets : coût fixe minimum de 80,00 €

Commandes supérieures à 1 000,00 € nets : application d'un pourcentage selon la région de destination

N.B. : La Doccia S.r.l. décline toute responsabilité pour d'éventuelles erreurs d'impression contenues dans le présent document.

GENERAL SALES CONDITIONS

1. Condiciones generales

1.1 Las presentes condiciones contractuales generales se aplican a todos los pedidos realizados a La Doccia S.r.l. Cualquier acuerdo distinto no será vinculante salvo que haya sido expresamente reconocido por escrito por La Doccia S.r.l.

1.2 Las condiciones que se indican a continuación se consideran íntegramente aceptadas con la realización del pedido.

1.3 Las presentes condiciones contractuales generales también se aplican a todas las futuras relaciones comerciales con la parte contratante y prevalecen sobre los usos comerciales nacionales e internacionales.

2. Ofertas y documentación

2.1 Las ofertas deberán formularse por escrito por La Doccia S.r.l. y tendrán una validez de 1 mes a partir de la fecha de emisión, salvo acuerdo distinto.

2.2 La Doccia S.r.l. se reserva los derechos exclusivos y la propiedad de toda la documentación relativa a la oferta. Dicha documentación no deberá ser puesta a disposición de terceros.

2.3 Los precios de cada partida de una oferta serán válidos únicamente si se confirman todas las partidas indicadas en la oferta.

3. Pedidos

3.1 Los pedidos serán aceptados por La Doccia S.r.l. únicamente si se envían por escrito y completos en todas sus partes.

3.2 Los acuerdos verbales o telefónicos solo serán vinculantes cuando se confirmen por escrito.

3.3 Ningún pedido podrá ser cancelado sin el consentimiento de La Doccia S.r.l., que se reserva el derecho de repercutir los gastos y cargos derivados.

3.4 No se aceptan modificaciones ni cancelaciones de pedidos de productos estándar o especiales (medidas especiales, serigrafías particulares, colores especiales).

3.5 Los pedidos podrán ser servidos parcial o totalmente por La Doccia S.r.l.

4. Precios

4.1 Salvo que se indique lo contrario en la confirmación del pedido, los precios se expresan en euros, sin IVA y franco fábrica.

4.2 El precio de cada producto incluye el embalaje. Los embalajes de madera o palets necesarios para garantizar una mayor protección de la mercancía se facturarán a precio de coste.

4.3 No están incluidos en el precio los gastos y cargos accesorios, tales como transporte, impuestos, montaje, instalación, etc., que correrán a cargo del comprador.

4.4 Los precios confirmados en el pedido serán vinculantes únicamente hasta la fecha de entrega acordada. En caso de aumento de los costes de los materiales entre la celebración del contrato y su ejecución, La Doccia S.r.l. se reserva el derecho de ajustar los precios.

5. Condiciones y plazos de entrega

5.1 Los días laborables se computan a partir de la confirmación del pedido. No se incluyen los periodos de cierre por vacaciones (agosto) o festivos (Navidad). Los plazos de entrega no son vinculantes y no podrán dar lugar a retrasos en los pagos ni a reclamaciones por daños. Se permiten entregas parciales.

5.2 En caso de fuerza mayor, incluidos huelgas, dificultades imprevisibles en el suministro de materiales o suspensión del trabajo, La Doccia S.r.l. podrá prolongar los plazos de ejecución del pedido.

5.3 El cumplimiento de los plazos de entrega presupone que el pedido esté completo en todas sus partes y que el cliente haya cumplido con sus obligaciones de pago.

5.4 De conformidad con el artículo 1510 del Código Civil italiano, la mercancía viaja por cuenta y riesgo del comprador, incluso cuando el envío corre a cargo de La Doccia S.r.l.

5.5 Una vez recibida la mercancía, el comprador deberá comprobarla inmediatamente. Las entregas incompletas o dañadas deberán anotarse en el albarán y comunicarse por escrito a La Doccia S.r.l. en un plazo de 8 días.

5.6 Los recambios y accesorios urgentes se enviarán mediante mensajería exprés únicamente previa solicitud escrita del cliente.

6. Condiciones de pago

6.1 A falta de acuerdo distinto, el pago será anticipado. En particular, para pedidos inferiores a 100,00 € sin IVA, la facturación se realizará mediante contra reembolso o transferencia bancaria anticipada.

6.2 En caso de retraso en el pago, La Doccia S.r.l. no estará obligada a realizar nuevas entregas, ni del pedido en curso ni de otros pedidos.

6.3 No se aceptan letras de cambio ni cheques.

6.4 Independientemente de las condiciones de pago acordadas, La Doccia S.r.l. podrá exigir el pago inmediato si se tiene conocimiento de hechos que pongan en duda la solvencia del cliente.

7. Garantía

7.1 La Doccia S.r.l. garantiza sus productos durante 24 meses a partir de la fecha de compra, acreditada mediante un documento válido. La garantía se concede conforme al Decreto Legislativo italiano n.º 24/2002 y a la Directiva 1999/44/CE.

7.2 La garantía obliga exclusivamente a la reparación y/o sustitución de los componentes defectuosos; se excluye cualquier otra reclamación.

7.3 No están cubiertos por la garantía los daños causados por un uso o montaje

incorrecto ni los daños producidos durante el transporte.

7.4 El derecho de garantía deberá ejercerse dentro del período de garantía a través del distribuidor donde se adquirió el producto, acompañado del certificado de garantía y del comprobante de compra.

7.5 Cualquier reparación, modificación o alteración realizada sin autorización escrita libera a La Doccia S.r.l. de toda obligación de garantía.

7.6 La responsabilidad por daños derivados de productos defectuosos se rige por las normativas nacionales que aplican la Directiva 1999/34/CE.

8. Devoluciones y reparaciones

8.1 Por norma general, no se aceptan devoluciones. Cualquier excepción deberá ser solicitada por escrito. No es posible la devolución de productos especiales, serigrafías o colores especiales.

8.2 No se aceptará ninguna devolución sin autorización escrita previa y sin acuerdo sobre el importe a abonar.

8.3 No se aceptará ninguna devolución para reparación sin autorización escrita previa.

9. Reserva de propiedad

9.1 La mercancía seguirá siendo propiedad de La Doccia S.r.l. hasta el pago total (art. 1523 del Código Civil italiano).

10. Catálogos, folletos, proyectos y otros

10.1 Las imágenes y los datos contenidos en los catálogos son orientativos y no vinculantes. La Doccia S.r.l. se reserva el derecho de sustituir los materiales por otros de calidad igual o superior y de realizar modificaciones técnicas.

10.2 La Doccia S.r.l. declina toda responsabilidad por posibles errores de impresión.

10.3 Los pesos y el número de bultos son aproximados y no vinculantes.

11. Lugar de ejecución y jurisdicción competente

11.1 El lugar de ejecución para cualquier entrega y pago es Padua.

11.2 A todos los contratos se les aplicará el derecho italiano.

11.3 La eventual nulidad de una cláusula no afectará a la validez de las demás disposiciones.

11.4 El único tribunal competente para cualquier controversia será el Tribunal de Padua.

12. Protección de datos

12.1 De conformidad con los artículos 7 y 13 del Decreto Legislativo 196/2003, los datos proporcionados serán tratados de acuerdo con la legislación sobre protección de datos personales y únicamente para fines comerciales.

13. Costes de transporte

Los gastos de transporte se facturarán de la siguiente manera:

Pedidos hasta 1.000,00 € netos: coste fijo mínimo de 80,00 €

Pedidos superiores a 1.000,00 € netos: se aplicará un porcentaje según la región de destino

Nota: La Doccia S.r.l. declina toda responsabilidad por posibles errores de impresión contenidos en el presente documento.

ALLGEMEINE GESCHÄFTSBEDINGUNGEN

1. Allgemeine Geschäftsbedingungen

1.1 Diese allgemeinen Vertragsbedingungen gelten für alle Bestellungen bei La Doccia S.r.l. Abweichende Vereinbarungen sind nur dann verbindlich, wenn sie von La Doccia S.r.l. ausdrücklich und schriftlich bestätigt wurden.

1.2 Die nachstehenden Bedingungen gelten mit Erteilung des Auftrags als vollständig akzeptiert.

1.3 Diese allgemeinen Vertragsbedingungen gelten auch für alle zukünftigen Geschäftsbeziehungen mit dem Vertragspartner und haben Vorrang vor nationalen und internationalen Handelsbräuchen.

2. Angebote und Unterlagen

2.1 Angebote müssen von La Doccia S.r.l. schriftlich erstellt werden und sind ab Ausstellungsdatum einen Monat gültig, sofern nichts anderes vereinbart ist.

2.2 La Doccia S.r.l. behält sich das ausschließliche Recht sowie das Eigentum an sämtlichen Angebotsunterlagen vor. Diese dürfen Dritten nicht zugänglich gemacht werden.

2.3 Die Preise der einzelnen Angebotspositionen gelten nur bei gleichzeitiger Bestätigung aller im Angebot enthaltenen Positionen.

3. Bestellungen

3.1 Bestellungen werden von La Doccia S.r.l. nur angenommen, wenn sie schriftlich und vollständig eingereicht werden.

3.2 Mündliche oder telefonische Vereinbarungen sind nur verbindlich, wenn sie schriftlich bestätigt wurden.

3.3 Eine Stornierung von Bestellungen ist nur mit Zustimmung von La Doccia S.r.l. möglich; das Unternehmen behält sich vor, entstehende Kosten und Aufwendungen in Rechnung zu stellen.

3.4 Änderungen oder Stornierungen von Bestellungen für Standard- oder Sonderanfertigungen (Sondermaße, spezielle Siebdrucke, Sonderfarben) werden nicht akzeptiert.

3.5 Bestellungen können auch teilweise von La Doccia S.r.l. ausgeführt werden.

4. Preise

4.1 Sofern in der Auftragsbestätigung nicht anders angegeben, verstehen sich die Preise in Euro, zzgl. MwSt., ab Werk.

4.2 Der Preis jedes Produkts beinhaltet die Verpackung. Erforderliche Holzverpackungen oder Paletten zur besseren Sicherung der Ware werden zum Selbstkostenpreis berechnet.

4.3 Nebenkosten wie Transport, Steuern, Montage, Installation usw. sind nicht im Preis enthalten und gehen zu Lasten des Käufers.

4.4 Die in der Auftragsbestätigung bestätigten Preise sind nur bis zum vereinbarten Liefertermin verbindlich. Bei steigenden Materialkosten zwischen Vertragsabschluss und Vertragserfüllung behält sich La Doccia S.r.l. das Recht auf eine entsprechende Preisanpassung vor.

5. Lieferbedingungen und Lieferzeiten

5.1 Betriebsferien (August) und Feiertage (Weihnachten) sind nicht eingeschlossen. Lieferzeiten sind unverbindlich und berechtigen weder zu Zahlungsverzögerungen noch zu Schadenersatzansprüchen. Teillieferungen sind zulässig.

5.2 Bei höherer Gewalt, einschließlich Streiks, unvorhersehbarer Lieferengpässe oder Arbeitsunterbrechungen, ist La Doccia S.r.l. berechtigt, die Lieferfristen entsprechend zu verlängern.

5.3 Die Einhaltung der Lieferfristen setzt eine vollständige Bestellung sowie die ordnungsgemäße Erfüllung der Zahlungsverpflichtungen durch den Käufer voraus.

5.4 Gemäß Art. 1510 des italienischen Zivilgesetzbuches erfolgt der Versand auf Risiko und Gefahr des Käufers, auch wenn der Versand von La Doccia S.r.l. übernommen wird.

5.5 Die Ware ist bei Lieferung unverzüglich zu prüfen. Unvollständige oder beschädigte Lieferungen müssen auf dem Lieferschein vermerkt und La Doccia S.r.l. innerhalb von 8 Tagen schriftlich gemeldet werden.

5.6 Dringende Ersatzteile und Zubehörteile werden ausschließlich auf ausdrückliche schriftliche Anfrage per Expressversand geliefert.

6. Zahlungsbedingungen

6.1 Sofern nichts anderes vereinbart ist, erfolgt die Zahlung im Voraus. Bestellungen unter 100,00 € (zzgl. MwSt.) werden per Nachnahme oder Vorausüberweisung abgewickelt.

6.2 Bei Zahlungsverzug ist La Doccia S.r.l. nicht verpflichtet, weitere Lieferungen auszuführen, weder im Rahmen des laufenden noch anderer Aufträge.

6.3 Wechsel und Schecks werden nicht akzeptiert.

6.4 Unabhängig von vereinbarten Zahlungsbedingungen kann La Doccia S.r.l. jederzeit die sofortige Zahlung verlangen, wenn Zweifel an der Kreditwürdigkeit des Kunden bestehen.

7. Garantie

7.1 La Doccia S.r.l. gewährt auf ihre Produkte eine Garantie von 24 Monaten ab Kaufdatum, nachgewiesen durch einen gültigen Kaufbeleg. Die Garantie erfolgt gemäß dem italienischen Gesetzesdekret Nr. 24/2002 sowie der EU-Richtlinie 1999/44/EG.

7.2 Die Garantie beschränkt sich ausschließlich auf die Reparatur und/oder den Austausch mangelhafter Teile; weitergehende Ansprüche sind ausgeschlossen.

7.3 Schäden durch unsachgemäßen Gebrauch, fehlerhafte Montage oder Transport

sind von der Garantie ausgeschlossen.

7.4 Garantieansprüche sind innerhalb der Garantiefrist über den Händler geltend zu machen und müssen mit Garantieschein und Kaufnachweis eingereicht werden.

7.5 Jede nicht autorisierte Reparatur, Änderung oder Manipulation entbindet La Doccia S.r.l. von jeglicher Garantieverpflichtung.

7.6 Die Haftung für Schäden durch fehlerhafte Produkte richtet sich nach den nationalen Vorschriften zur Umsetzung der Richtlinie 1999/34/EG.

8. Rücknahmen und Reparaturen

8.1 Rücknahmen sind grundsätzlich ausgeschlossen. Ausnahmen bedürfen einer schriftlichen Anfrage. Sonderanfertigungen, Siebdrucke und Sonderfarben sind vom Umtausch ausgeschlossen.

8.2 Rücknahmen erfolgen nur nach vorheriger schriftlicher Genehmigung und Vereinbarung über den gutzuschreibenden Betrag.

8.3 Rücksendungen zur Reparatur sind nur nach vorheriger schriftlicher Genehmigung zulässig.

9. Eigentumsvorbehalt

9.1 Die Ware bleibt bis zur vollständigen Bezahlung Eigentum von La Doccia S.r.l. (Art. 1523 ital. ZGB).

10. Kataloge, Prospekte, Projekte und sonstige Unterlagen

10.1 Abbildungen und Angaben in Katalogen sind unverbindlich. La Doccia S.r.l. behält sich vor, Materialien durch gleich- oder höherwertige zu ersetzen und technische Änderungen vorzunehmen.

10.2 La Doccia S.r.l. übernimmt keine Haftung für eventuelle Druckfehler.

10.3 Gewichtsangaben und Anzahl der Packstücke sind unverbindlich und können variieren.

11. Erfüllungsort und Gerichtsstand

11.1 Erfüllungsort für Lieferungen und Zahlungen ist Padua.

11.2 Es gilt ausschließlich italienisches Recht.

11.3 Die Unwirksamkeit einzelner Klauseln berührt nicht die Gültigkeit der übrigen Bestimmungen.

11.4 Ausschließlicher Gerichtsstand ist das Gericht von Padua.

12. Datenschutz

12.1 Gemäß den Artikeln 7 und 13 des Gesetzesdekrets 196/2003 werden die vom Kunden bereitgestellten Daten unter Einhaltung der Datenschutzbestimmungen ausschließlich zu geschäftlichen Zwecken verarbeitet.

13. Transportkosten

Die Transportkosten werden wie folgt berechnet:

Bestellungen bis 1.000,00 € netto: Mindestpauschale von 80,00 €

Bestellungen über 1.000,00 € netto: prozentuale Berechnung je nach Lieferregion

Hinweis: La Doccia S.r.l. übernimmt keine Haftung für eventuelle Druckfehler in diesem Dokument.

Colori e Finiture

/ Colours and finishes / Couleurs et finitions
/ Colores y acabados / Farben und Oberflächen

LASTRE ACRILICO MINIPISCINE

/ Acrylic sheets for mini pools / Plaques en acrylique pour mini-piscines / Láminas acrílicas para minipiscinas / Acrylplatten für Minipools

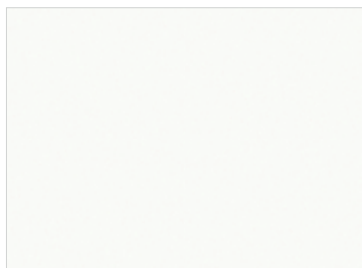

Bianco / White / Blanc
/ Blanco / Weiß



Madreperla / Mother-of-pearl
/ Nacre / Nácar / Perlmutter

SOLID SURFACE

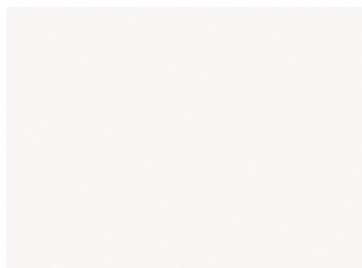

Bianco / White / Blanc
/ Blanco / Weiß

LASTRE ACRILICO VASCHE

Acrylic sheets for bathtubs / Plaques en acrylique pour baignoires / Láminas acrílicas para bañeras / Acrylplatten für Badewannen

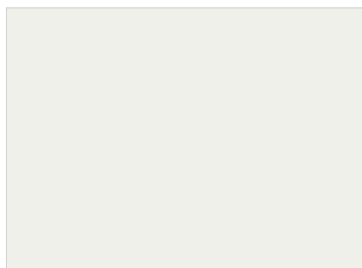

Bianco lucido /
Glossy White

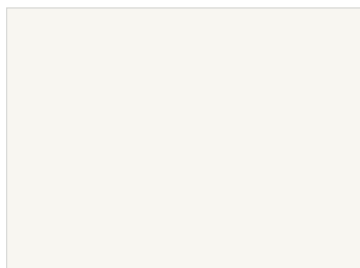

Edelweiss Bianco opaco /
Edelweiss Matt White

FINITURE PANNELLI

Panel finishes / Finitions des panneaux / Acabados de paneles / Oberflächen der Paneele



Elegant Tea for Two TT



Tortona Natural TN



Kashmir KS



Graphite GP

Albatros

PRINTED IN ITALY // GENNAIO 2026

www.albatroswellness.it

LA DOCCIA S.R.L. a Socio Unico
Sede legale: Via G. Galilei 5, 35030 - Veggiano (PD)
C.F. e P.Iva 02448060281
Tel. +39 049 9008917

Sede operativa: Via Industriale sul Cosa, 8 - 33097 Spilimbergo (PN)
Tel. +39 0427 952070
mail: info@albatroswellness.it